

Modular Pulsed IV (MPIV)

High Power Current & Voltage Characterization

General

The MPIV – Modular Pulsed IV is used for High Power current & voltage characterization of semiconductor devices. It is also well suited for applications requiring precise high current and voltage pulses. The Drain Pulse Module (DPM) uses an external high-current supply while the Gate Pulse Module (GPM) has an internal high-precision voltage supply. Additionally, the MPIV can be synchronized with an external or internal trigger.

The DPM is the core of the system. Its internal microcontroller uses precision Pulse Width Modulation (PWM) modules with complementary outputs and programmable dead-time in order to generate and synchronize the pulses for both drain and gate bias. The pulse width is adjustable from 200ns to 2ms; pulse repetition rate from 500Hz to 1MHz, with a maximum duty cycle of 50%.



Typical Measurement Setup

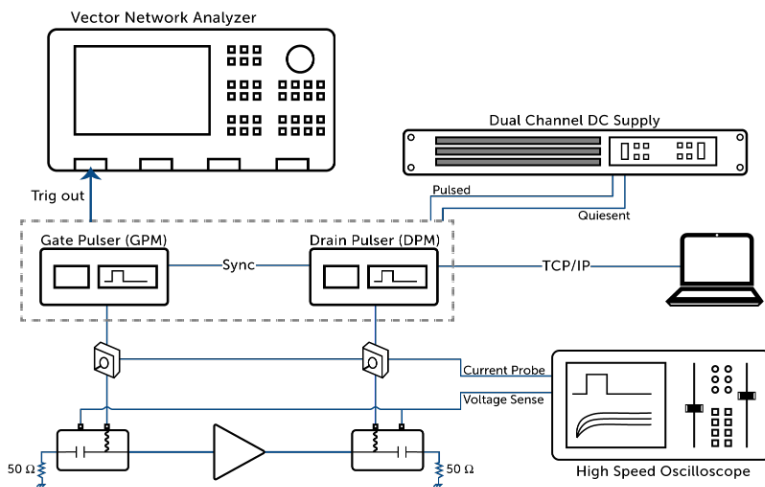

Pulsed Waveform*

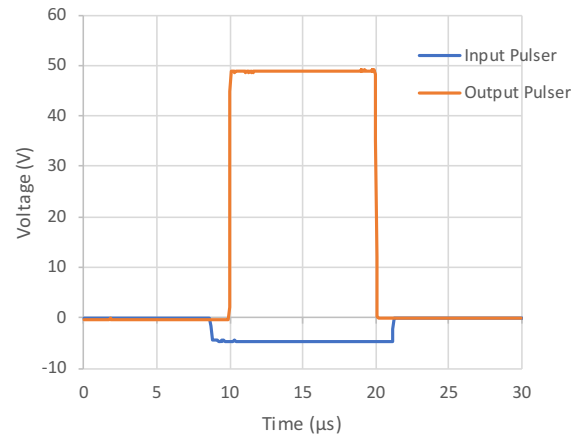

Specifications

		DPM (Drain Pulse Module)	GPM (Gate Pulse Module)
Pulse Voltage	Max Voltage	200 V	±10 V
	Rising Time (10% to 90%)	20 ns	20 ns
Pulse Current	Max Current	17 A	100 mA
Pulse Width	Min. Pulse	200 ns	200 ns
	Resolution	33 ns	33 ns
Duty Cycle	Min. Duty Cycle	0.01 %	0.01 %
	Max. Duty Cycle	100%	50 %
Quiescent	Max. Voltage	200 V	±10 V
	Max. Current	1 A	100 mA

* on 50 Ω load

DS-MPIV-V04

1603 St. Regis, Dollard-des-Ormeaux, Quebec, Canada H9B 3H7
T: (514) 684-4554 F: (514) 684-8581 W: www.focus-microwaves.com

The information contained in this leaflet can change without prior notice, all rights reserved.