



Manta

G-419 NIR

- NIR enhanced CMOS sensor
- Power over Ethernet option
- Angled-head and board level variants
- Video-iris lens control

GigE camera with NIR optimized CMOSIS/ams CMV4000 CMOS sensor

Manta G-419B NIR is a machine vision camera that incorporates the NIR-optimized Type 1 (16 mm diagonal) CMOSIS/ams CMV4000 CMOS sensor. At full resolution, this camera runs 28.6 frames per second. With a smaller region of interest, higher frame rates are possible. The Manta is one of Allied Vision's versatile GigE Vision cameras with a wide range of features. Particular highlights are the three look-up tables, a robust metal housing, and many modular options. By default, the Manta G-419B NIR ships with no optical filter.

Benefits and features

- GigE Vision interface with Power over Ethernet option
- Screw mount RJ45 Ethernet connector for secure operation in industrial environments
- Supports cable lengths up to 100 meters (CAT-6 recommended)
- Trigger over Ethernet Action Commands allow for a single cable solution to reduce system costs
- Comprehensive I/O functionality for simplified system integration
- Popular C-Mount lens mount
- Easy camera mounting via standard M3 threads on top and bottom of housing or optional tripod adapter
- Easy software integration with Allied Vision's [Vimba SDK](#) and compatibility to the most popular [third party image-processing libraries](#).
- Defect pixel masking feature with the Defect Mask Loader tool that allows you to manage a user defined defective pixel list to match your application and optimize the life cycle of the camera.

Hardware options

- Various housing options: Select between standard housing, angled-head, or board level versions

- Various lens mounts: Select between C-Mount, CS-Mount, or M12-Mount (adapter)
- Various optical filters: Select between B 270 ASG protection glass and filter types: Jenofilt 217 IR cut filter, Hoya C-5000 IR cut filter, RG715 IR pass filter, or RG830 IR pass filter.
- Available with Power over Ethernet compliant interface
- Available with white medical design

See the [Modular Concept](#) for lens mount, housing variants, optical filters, case design, and other modular options. See the [Customization and OEM Solutions](#) webpage for additional options.

Specifications

Manta	G-419 NIR
Interface	IEEE 802.3 1000BASE-T, IEEE 802.3af (PoE) optional
Resolution	2048 (H) × 2048 (V)
Sensor	CMOSIS/ams CMV4000 NIR
Sensor type	CMOS
Shutter mode	Global shutter
Sensor size	Type 1
Pixel size	5.5 μm × 5.5 μm
Lens mounts (available)	C-Mount, CS-Mount, S-Mount
Max. frame rate at full resolution	28.6 fps
ADC	12 Bit
Image buffer (RAM)	128 MByte
Imaging performance	
Imaging performance data is based on the evaluation methods in the EMVA 1288 Release 3.1 standard for characterization of image sensors and cameras. Measurements are typical values for NIR models measured at full resolution without optical filter. Contact Sales or AE for more information.	
Quantum efficiency at 529 nm	77 %
Quantum efficiency at 850 nm	40 %
Temporal dark noise	9.5 e ⁻
Saturation capacity	9500 e ⁻
Dynamic range	60.0 dB
Absolute sensitivity threshold	13.4 e ⁻
Output	
Bit depth	8/12 Bit
Monochrome pixel formats	Mono8, Mono12, Mono12Packed
General purpose inputs/outputs (GPIOs)	
Opto-isolated I/Os	2 inputs, 2 outputs
RS232	1
Operating conditions/dimensions	

Manta	G-419 NIR
Operating temperature	+5 °C to +45 °C ambient (without condensation)
Power requirements (DC)	8 to 30 VDC AUX or IEEE 802.3af PoE
Power consumption	External power: 2.7 W at 12 VDC Power over Ethernet: 3.1 W
Mass	190 g; 200 g (PoE)
Body dimensions (L × W × H in mm)	86.4 × 44 × 29 (including connectors)
Regulations	CE: 2014/30/EU (EMC), 2011/65/EU, including amendment 2015/863/EU (RoHS); FCC Class B; CAN ICES-3 (B)

Quantum efficiency

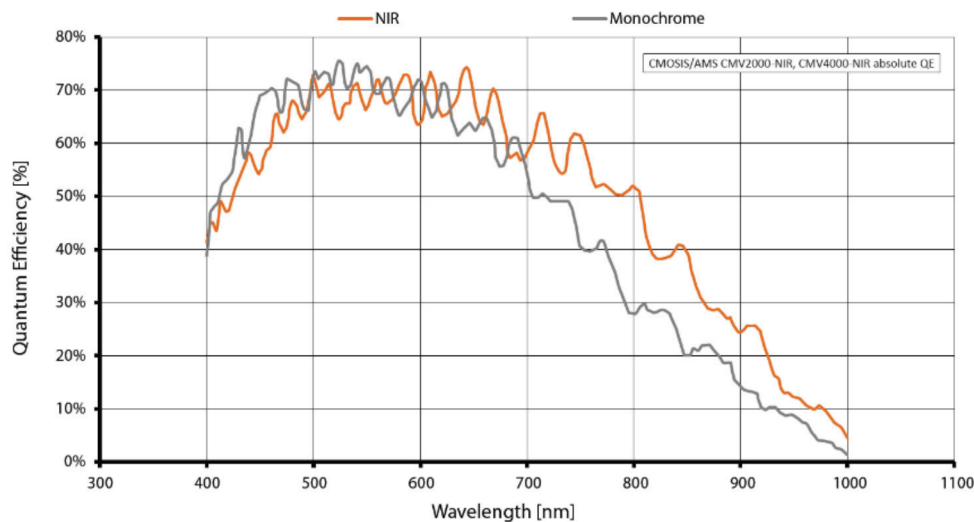

Features

Image optimization features:

- Auto gain (manual gain control: 0 to 26 dB; 1 dB increments)
- Auto exposure (34 μs to 126 s; 1 μs increments)
- Black level (offset)
- Decimation
- Defect pixel masking (user defined with Defect Mask Loader tool)
- Gamma correction



- Three look-up tables
- Piecewise Linear HDR mode
- Region of interest, separate region for auto features
- Reverse X/Y

Camera control features:

- Auto-iris (video type)
- Event channel
- Image chunk data
- IEEE 1588 Precision Time Protocol
- Storable user sets
- StreamBytesPerSecond (easy bandwidth control)
- Stream hold
- Sync out modes: Trigger ready, input, exposing, readout, imaging, strobe, GPO
- Temperature monitoring (main board)
- Trigger over Ethernet Action Commands

Technical drawing

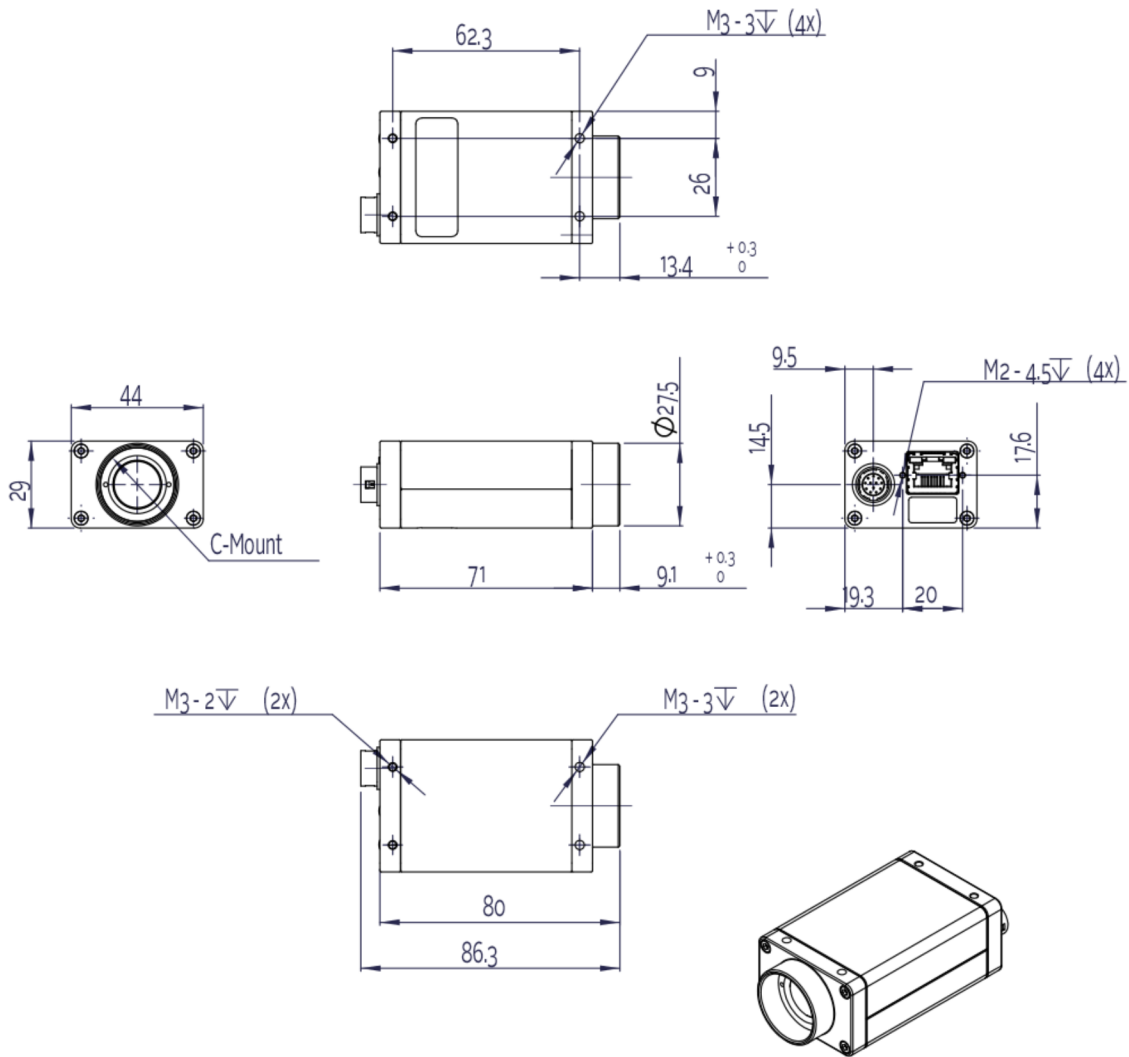



Applications

Manta G-419B NIR is ideal for a wide range of applications including:

- Multimedia and entertainment
- Machine vision
- Security and surveillance
- Metrology and inspection systems
- Industrial image processing