

Mako G

G-503



- ON Semiconductor CMOS sensor
- Power over Ethernet
- Switchable shutter modes
- Ultra-compact design

Gigabit Ethernet camera, ON Semiconductor CMOS sensor, 14 fps

Mako G-503 is a 5.0 megapixel GigE machine vision camera that incorporates the high quality Type 1/2.5 (7.13 mm diagonal) ON Semiconductor MT9P031 (monochrome) or MT9P006 (color) CMOS sensor. At full resolution, this camera runs 14 frames per second. With a smaller region of interest, higher frame rates are possible.

Mako G cameras have an ultra-compact form factor and the same mounting positions as many analog cameras. All models include Power over Ethernet, three opto-isolated outputs, and a 64 MB image buffer. The image quality profits from the precisely aligned sensor. By default monochrome models ship with no optical filter and color models ship with a Type Hoya C-5000 IR cut filter.

Benefits and features

- Monochrome (G-503B) and color (G-503C) models
- GigE Vision interface with Power over Ethernet
- Screw mount RJ45 Ethernet connector for secure operation in industrial environments
- Supports cable lengths up to 100 meters (CAT-6 recommended)
- Comprehensive I/O functionality for simplified system integration
- Popular C-Mount lens mount
- Easy camera mounting via standard M3 threads on top and bottom of housing or optional tripod adapter
- Easy software integration with Allied Vision's [Vimba Suite](#) and compatibility to the most popular [third party image-processing libraries](#).
- Defect pixel masking feature with the Defect Mask Loader tool that allows you to manage a user defined defective pixel list to match your application and optimize the life cycle of the camera.
- Select between B 270 ASG protection glass and filter types: Jenofilt 217 IR cut filter, Hoya C-5000 IR cut filter, RG715 IR pass filter, or RG830 IR pass filter

See the [Modular Concept](#) for lens mount and optical filter options.

See the [Customization and OEM Solutions](#) webpage for additional options.

Specifications

Mako G	G-503
Interface	IEEE 802.3 1000BASE-T, IEEE 802.3af (PoE)
Resolution	2592 (H) × 1944 (V)
Sensor	ON Semi MT9P031 / MT9P006
Sensor type	CMOS
Shutter mode	Global reset and Rolling shutter
Sensor size	Type 1/2.5
Pixel size	2.2 μm × 2.2 μm
Lens mounts (available)	C-Mount, CS-Mount, S-Mount
Max. frame rate at full resolution	14 fps
ADC	12 Bit
Image buffer (RAM)	64 MByte
Imaging performance	
Imaging performance data is based on the evaluation methods in the EMVA 1288 Release 3.1 standard for characterization of image sensors and cameras. Measurements are typical values for monochrome models measured at full resolution without optical filter. Contact Sales or AE for more information.	
Quantum efficiency at 529 nm	55 %
Temporal dark noise	7.5 e ⁻
Saturation capacity	6000 e ⁻
Dynamic range	57.6 dB
Absolute sensitivity threshold	8.0 e ⁻
Output	
Bit depth	8/12 Bit
Monochrome pixel formats	Mono8, Mono12, Mono12Packed
YUV color pixel formats	YUV411Packed, YUV422Packed, YUV444Packed
RGB color pixel formats	RGB8Packed, BGR8Packed
Raw pixel formats	BayerGR8, BayerGR12Packed, BayerGR12
General purpose inputs/outputs (GPIOs)	
Opto-isolated I/Os	1 input, 3 outputs
Operating conditions/dimensions	
Operating temperature	+5 °C to +45 °C housing temperature
Power requirements (DC)	12 to 24 VDC AUX or 802.3at Type 1 PoE
Power consumption	2.0 W at 12 VDC; 2.2 W PoE
Mass	80 g (with C-Mount)

Mako G

Body dimensions (L × W × H in mm)

Regulations

G-503

60.5 × 29.2 × 29.2 (including connectors)

CE: 2014/30/EU (EMC), 2011/65/EU, including amendment 2015/863/EU (RoHS); FCC Class B; CAN ICES-003

Quantum efficiency

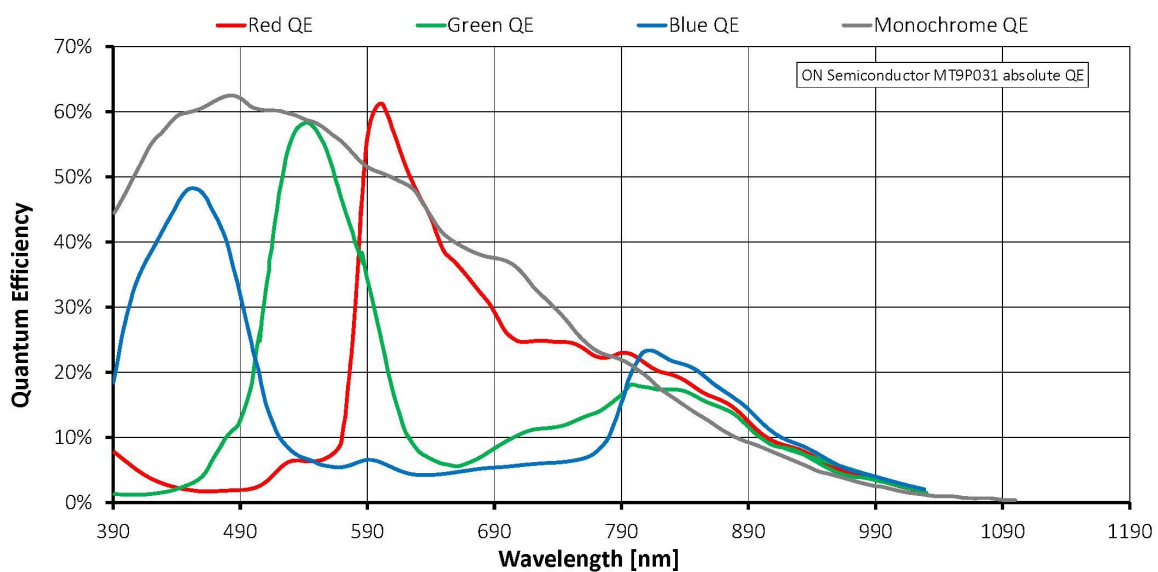

Features

Image optimization features:

- Auto gain (manual gain control: 0 to 24 dB; 1 dB increments)
- Auto exposure (31 μ s to 1 s; 36.4 μ s increments)
- Auto white balance (G-503C only)
- Binning
- Color transformation, hue, saturation (G-503C only)
- Decimation
- Defect pixel masking (user defined with Defect Mask Loader tool)
- Gamma correction
- One look-up table
- Region of interest, separate region for auto features
- Reverse X/Y



Camera control features:

- Event channel
- Image chunk data
- Storable user sets
- StreamBytesPerSecond (bandwidth control)
- Stream hold
- Switchable Rolling and Global Reset shutter modes
- Sync out modes: Trigger ready, input, exposing, readout, imaging, strobe, GPO
- Temperature monitoring (main board only)

Technical drawing

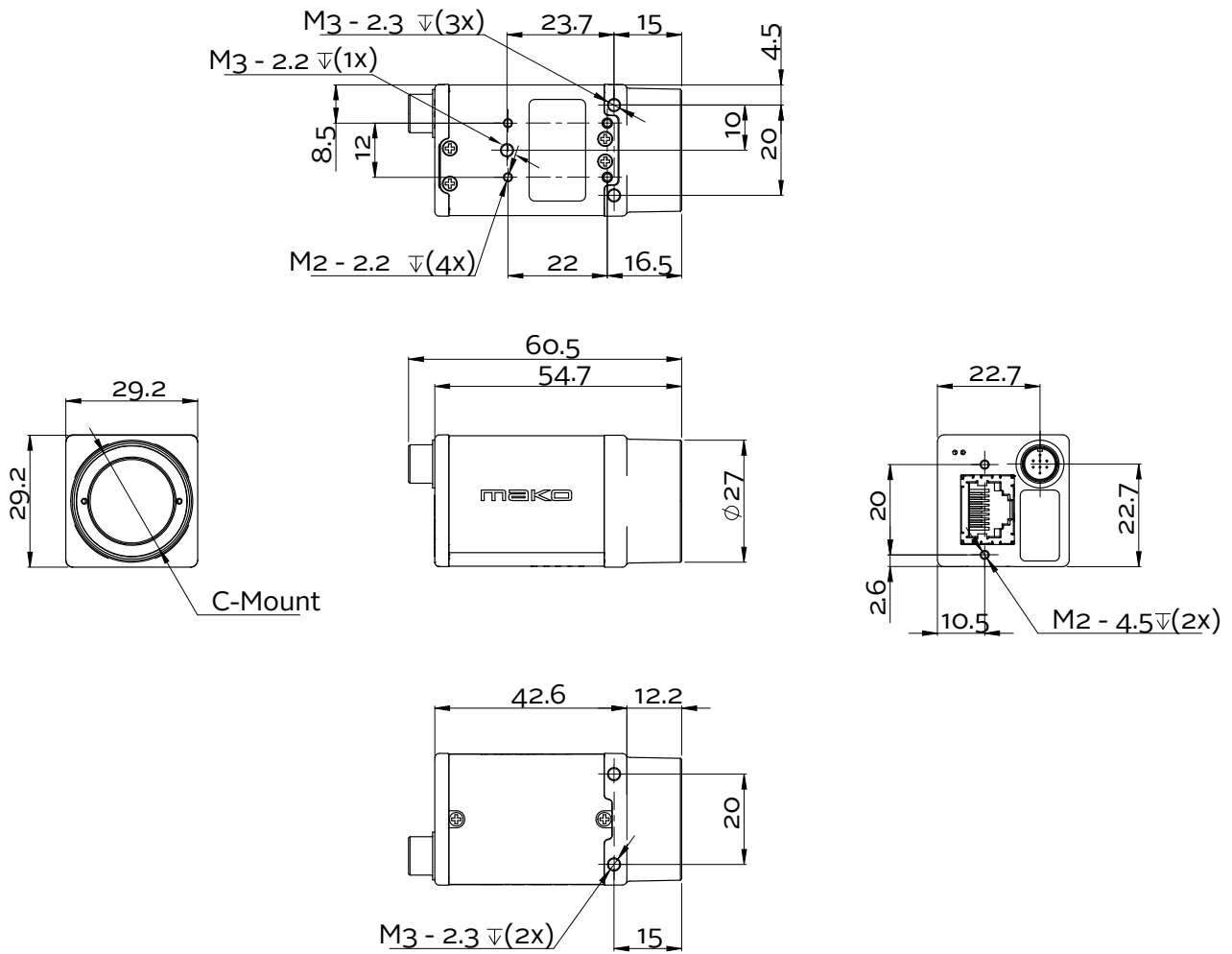



Applications

Mako G-503 is suitable for a wide range of applications including:

- Robotics
- Quality control
- Inspection, surveillance
- Industrial imaging
- Machine vision
- Logistics