

# InfinityQuad Probe: Pad Layout Rules

## Rule 100: Pad Size

Minimum pad sizes are shown in [Table 1](#) and [Table 2](#).



**NOTE**

*Recommended minimum pad sizes include error margins for automated measurements (on a FormFactor semi-automatic station) and over temperature probing (-40° to +125°C).*

The longer dimension on the rectangular pad represents the direction of probe scrub. To provide for probing ease and parasitics low enough for many applications, use 100 x 100 μ pads for 150 μ pitch and above, unless there is a reason to do otherwise. Increase pad size when using an autoprober to account for errors. The recommended amount of increase depends on the station and the type of measurement. As a general rule, however, increase the pad size by 5 μ in both length and width.

Table 1. Minimum pad size rule in 5 μ increments (units in μ x μ).

# of Contacts (include X)	75 μ pitch	80 μ pitch	100 μ pitch	125 μ pitch	150 μ pitch	200 μ pitch	250 μ pitch
4	25 x 45						
5							
6							
7							
8							
9							
10			30 x 50				
11							
12							
13							
14							
15							
16					35 x 55		
17							
18							
19						40 x 60	
20							
21							
22							
23							45 x 65
24							
25							

# InfinityQuad Probe: Pad Layout Rules

Table 1. Minimum pad size rule in 1 μ increments (units in μ x μ).

# of Contacts (include X)	75 μ pitch	80 μ pitch	100 μ pitch	125 μ pitch	150 μ pitch	200 μ pitch	250 μ pitch
4	25 x 45	26 x 46	26 x 46	26 x 46	26 x 46	27 x 47	28 x 48
5	26 x 46	26 x 46	26 x 46	26 x 46	27 x 47	28 x 48	28 x 48
6	26 x 46	26 x 46	26 x 46	27 x 47	27 x 47	28 x 48	29 x 49
7	26 x 46	26 x 46	27 x 47	27 x 47	28 x 48	29 x 49	30 x 50
8	26 x 46	27 x 47	27 x 47	28 x 48	28 x 48	30 x 50	31 x 51
9	27 x 47	27 x 47	27 x 47	28 x 48	29 x 49	30 x 50	32 x 52
10	27 x 47	27 x 47	28 x 48	28 x 48	29 x 49	31 x 51	32 x 52
11	27 x 47	27 x 47	28 x 48	29 x 49	30 x 50	32 x 52	33 x 53
12	27 x 47	28 x 48	28 x 48	29 x 49	30 x 50	32 x 52	34 x 54
13	28 x 48	28 x 48	29 x 49	30 x 50	31 x 51	33 x 53	35 x 55
14	28 x 48	28 x 48	29 x 49	30 x 50	31 x 51	33 x 53	36 x 56
15	28 x 48	28 x 48	29 x 49	30 x 50	32 x 52	34 x 54	36 x 56
16	28 x 48	29 x 49	30 x 50	31 x 51	32 x 52	35 x 55	37 x 57
17	29 x 49	29 x 49	30 x 50	31 x 51	33 x 53	35 x 55	38 x 58
18	29 x 49	29 x 49	30 x 50	32 x 52	33 x 53	36 x 56	39 x 59
19	29 x 49	29 x 49	31 x 51	32 x 52	34 x 54	37 x 57	40 x 60
20	29 x 49	30 x 50	31 x 51	32 x 52	34 x 54	37 x 57	40 x 60
21	30 x 50	30 x 50	31 x 51	33 x 53	35 x 55	38 x 58	41 x 61
22	30 x 50	30 x 50	32 x 52	33 x 53	35 x 55	39 x 59	42 x 62
23	30 x 50	30 x 50	32 x 52	34 x 54	36 x 56	39 x 59	43 x 63
24	30 x 50	31 x 51	32 x 52	34 x 54	36 x 56	40 x 60	44 x 64
25	30 x 50	31 x 51	32 x 52	34 x 54	36 x 56	40 x 60	44 x 64

## Rule 101: Passivation Window

This rule applies only when the final passivation layer is above the metalization. Minimum passivation window sizes are the same as minimum pad sizes. Use pad sizes larger than the passivation window whenever possible for reliability. To provide clearance for the probe tip, the distance from the top of the probe pad to the top of passivation layer should not exceed 40 μ.

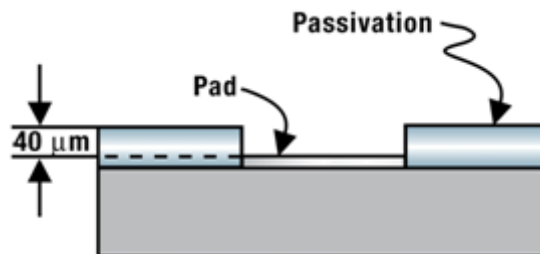

# InfinityQuad Probe: Pad Layout Rules

## Rule 102: Number of Contacts and Pad Pitch

It is possible to have between 4 and 25 contacts. Available pitches and recommended maximum operational frequencies when using the InfinityQuad probe are shown in Table 3.

Table 1. Available pitch and the recommended maximum operational frequency.

	75 $\mu$ pitch	80 $\mu$ pitch	100 $\mu$ pitch	125 $\mu$ pitch	150 $\mu$ pitch	200 $\mu$ pitch	250 $\mu$ pitch
GSG layout	110GHz						
GS or SG layout	67 GHz						

## Rule 103: Corner Pads Allowed

Corner pads are allowed for all available pitches before and after touch down. However, reduced overtravel may be required, as well as a slight adjustment of the probe in the scrub direction to avoid collision with the quadrant probes.

Quadrant capability: scope view

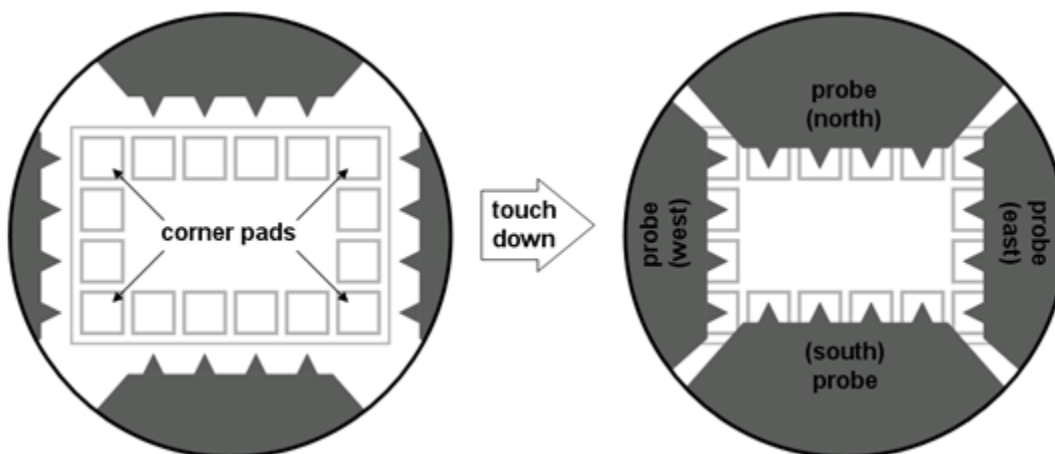

### NOTE

InfinityQuad probes are fully quadrant compatible when used exclusively with the same pitch. For quadrant compatibility with other types of pitches or probes, please contact FormFactor.

# InfinityQuad Probe: Pad Layout Rules

## Rule 104: Single-Row Pad Spacing

The minimum center-to-center pad spacing for opposing, side-by-side probes contacting the same line of pads is  $40 \mu + (\text{Pitch}_A + \text{Pitch}_B) / 2$ .

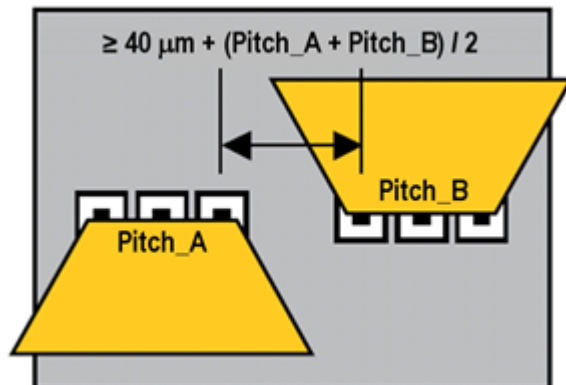

## Rule 105: Parallel-Row Pad Spacing

The minimum center-to-center pad spacing between facing probes on parallel rows of pads is  $150 \mu$ . Note that this spacing is based on no more than  $150 \mu$  of applied probe overtravel. The purpose of this rule is to avoid potential excessive overtravel conditions which may result in contact between opposing probes. For some cases, it may be necessary to reduce the spacing to  $65 \mu$  (for example, 138-356 ISS with 0.5 ps thru).

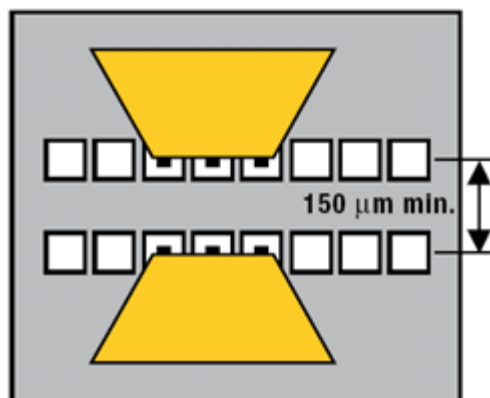

## Rule 106: Pad Height Variation

The maximum pad height variation in a row of pads is  $0.5 \mu$ . Pad height variation usually occurs because pads are constructed using different metal stacks. Be sure to use the same metal layers to construct all pads.

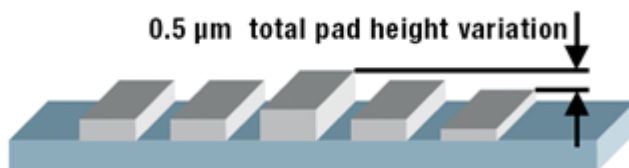

# InfinityQuad Probe: Pad Layout Rules

## Rule 107: Planarity Requirements

During probing, non-planarity between the probe contacts and the pads should not exceed 2000 ppm or 0.1°. Non-planarity can be compensated by using the FormFactor RF positioner; which can be adjusted over  $\pm 3.5^\circ$ .

## Rule 108: Pads at 90° Only

Rows of pads meeting at an angle must be orthogonal (at 90°).

## Rule 109: Pads are collinear

All pads contacted by an individual probe must be collinear.

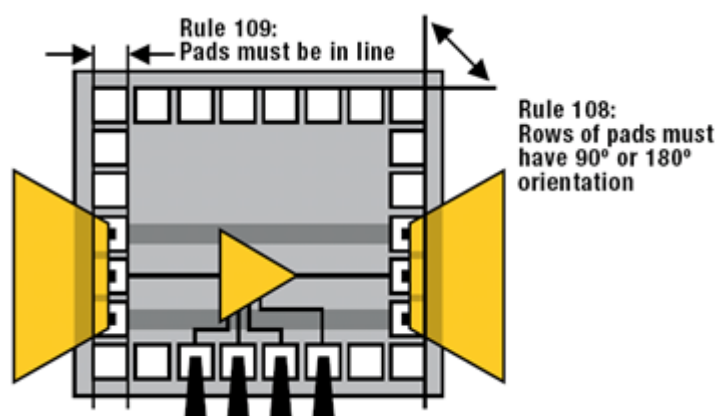

## Rule 110: Pads Have Equal Pitch

All pads contacted by an individual probe must have constant pitch or multiples of the constant pitch.

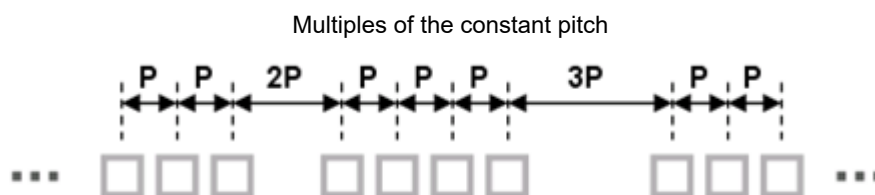

## Rule 111: Pads on Top

All probe pads must be on the substrate top.

# InfinityQuad Probe: Pad Layout Rules

## Rule 112: Maximum DUT Size for MicroChamber TopHat Compatibility

This rule only applies when using the MicroChamber TopHat. The largest DUT the probe can measure inside the 5-inch TopHat is 7 x 7 mm, measured from center to center of the pads. For the 6-inch TopHat, the maximum DUT size is 30 x 30 mm.

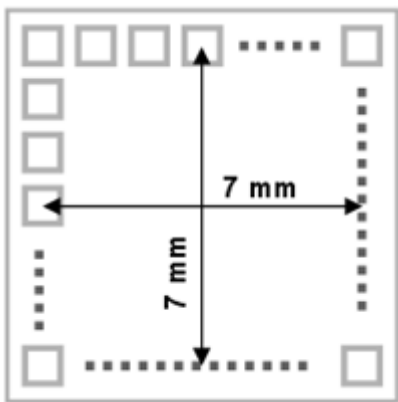

Maximum DUT size for 5-inch TopHat (measured from pads center to center)

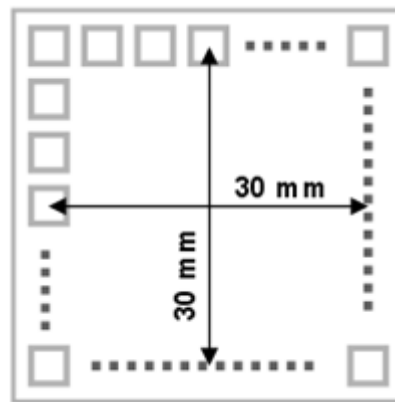

Maximum DUT size for 6-inch TopHat (measured from pads center to center)

© Copyright 2018 FormFactor, Inc. All rights reserved. No part of this document may be reproduced, transmitted or displayed in any form or by any means except as duly authorized by FormFactor, Inc. FormFactor and the FormFactor logo are trademarks of FormFactor, Inc. All other trademarks are the property of their respective owners.

### Important Notice

While the information contained herein is believed to be accurate as of the date hereof, no express or implied representations or warranties are made with respect to its accuracy or completeness. FormFactor, Inc., and its subsidiaries disclaim liability for any inaccuracies or omissions. All information is subject to change without notice.

Users are required to read and follow carefully all safety, compliance and use instructions. Users assume all loss and liability arising from the use of products in any manner not expressly authorized. The conditions and methods of use of products and information referred to herein are the entire responsibility of the user and, to the maximum extent permitted by applicable law, FormFactor, Inc., and its subsidiaries shall not be liable for any damages, losses, costs or expenses arising out of, or related to, the use thereof.

No license, express or implied, by estoppel or otherwise, under any intellectual property right is granted in connection herewith. Users shall take all actions required to avoid intellectual property infringement.

### Corporate Headquarters

7005 Southfront Road  
Livermore, CA 94551  
Phone: 925-290-4000  
[www.formfactor.com](http://www.formfactor.com)

