

Prosilica GT

3300



- Versatile temperature range for extreme environments
- IEEE 1588 PTP
- Power over Ethernet
- P-Iris and DC-Iris lens control

Description

8.1 MP CCD machine vision camera for extreme environments

Prosilica GT3300 is a 8.1 Megapixel camera with a GigE Vision compliant Gigabit Ethernet port and Hirose I/O port. Prosilica GT3300 is offered in both monochrome and color models. This camera incorporates the high-quality ON Semiconductor KAI-08050 TRUESENSE Gen 2 CCD sensor providing excellent monochrome and color image quality. At full resolution, this camera runs 14.7 frames per second. With a smaller region of interest, higher frame rates are possible. It is a rugged camera designed to operate in extreme environments and fluctuating lighting conditions. This camera offers Precise iris lens control allowing users to fix the aperture size to optimize depth of field, exposure, and gain without the need for additional control elements. By default monochrome models ship with no optical filter and color models ship with an IRC30 IR cut filter.

Benefits and features:

- Monochrome (GT3300) and color (GT3300C) models
- GigE Vision interface with Power over Ethernet
- Screw mount RJ45 Ethernet connector for industrial environments
- Supports cable lengths up to 100 meters (CAT-5e or CAT-6)
- Trigger over Ethernet (ToE) Action Commands allow for a single cable solution
- Popular F-Mount lens mount
- Standard M3 mounting holes and optional tripod adapter
- Support for popular third party image-processing libraries including Cognex VisionPro, MathWorks MATLAB, National Instruments LabVIEW, Stemmer Imaging Common Vision Blox, MVTec HALCON and MERLIC



Options:

- Available with CS-Mount, F-Mount, EF-Mount Birger, M42-Mount
- Available with IR cut filter or protection glass

See the [Modular Concept](#) for lens mount and optical filters options. See the [Customization and OEM Solutions](#) page for additional options.

Specifications

Prosilica GT	3300
Interface	IEEE 802.3 1000BASE-T, IEEE 802.3af (PoE)
Resolution	3296 (H) × 2472 (V)
Sensor	ON Semi KAI-08050
Sensor type	CCD Progressive
Sensor size	Type 4/3
Pixel size	5.5 μm × 5.5 μm
Lens mount (default)	F-Mount
Max. frame rate at full resolution	14.7 fps
ADC	14 bit
Image buffer (RAM)	128 MByte
Output	
Bit depth	14 (monochrome); 12 (color) bit
Monochrome pixel formats	Mono8, Mono12, Mono12Packed, Mono14
YUV color pixel formats	YUV411Packed, YUV422Packed, YUV444Packed
RGB color pixel formats	RGB8Packed, BGR8Packed, RGBA8Packed, BGRA8Packed
Raw pixel formats	BayerGR8, BayerGR12, BayerRG12Packed
General purpose inputs/outputs (GPIOs)	
TTL I/Os	1 input, 2 outputs
Opto-isolated I/Os	1 input, 2 outputs
RS232	1
Operating conditions/dimensions	
Operating temperature	-20 °C to +60 °C ambient (without condensation)
Power requirements (DC)	7 to 25 VDC; PoE
Power consumption	5.6 W @ 12 VDC; 6.9 W PoE
Mass	314 g
Body dimensions (L × W × H in mm)	121 × 59.7 × 59.7 (including connectors)

Prosilica GT

Regulations

3300

CE: 2014/30/EU (EMC), 2011/65/EU (RoHS); FCC
Class A; CAN ICES-003 Issue 4/5

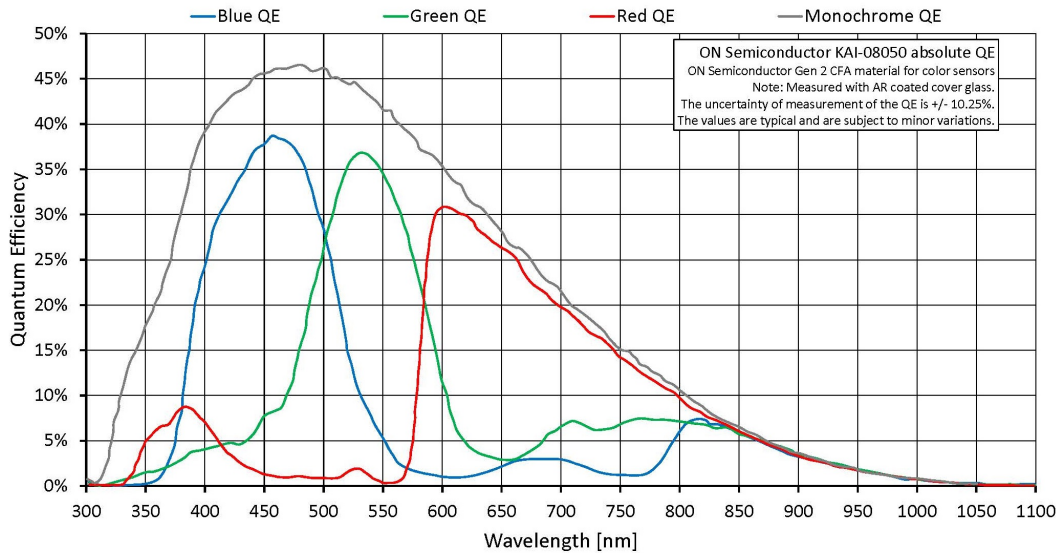

Features

Image optimization features:

- Auto gain (manual gain control: 0 to 32 dB)
- Auto exposure (manual exposure control: 10 μ s to 26.8 s)
- Auto white balance (GT3300C only)
- Binning (horizontal and vertical)
- Color correction, hue, saturation (GT3300C only)
- Column defect masking
- Decimation X/Y
- Gamma correction
- Three look-up tables (LUTs)
- Region of interest (ROI), separate ROI for auto features
- Reverse X/Y

Camera control features:

- P-Iris and DC-Iris lens control
- Event channel



- Image chunk data
- IEEE 1588 Precision Time Protocol (PTP)
- RS232
- Storable user sets
- StreamBytesPerSecond (bandwidth control)
- Stream hold
- Sync out modes: Trigger ready, input, exposing, readout, imaging, strobe, GPO
- Tap mode switchable in Vimba Viewer 2.0 or later (four-tap, one-tap)
- Temperature monitoring (main board and sensor board)
- Trigger over Ethernet (ToE) Action Commands

Technical drawing

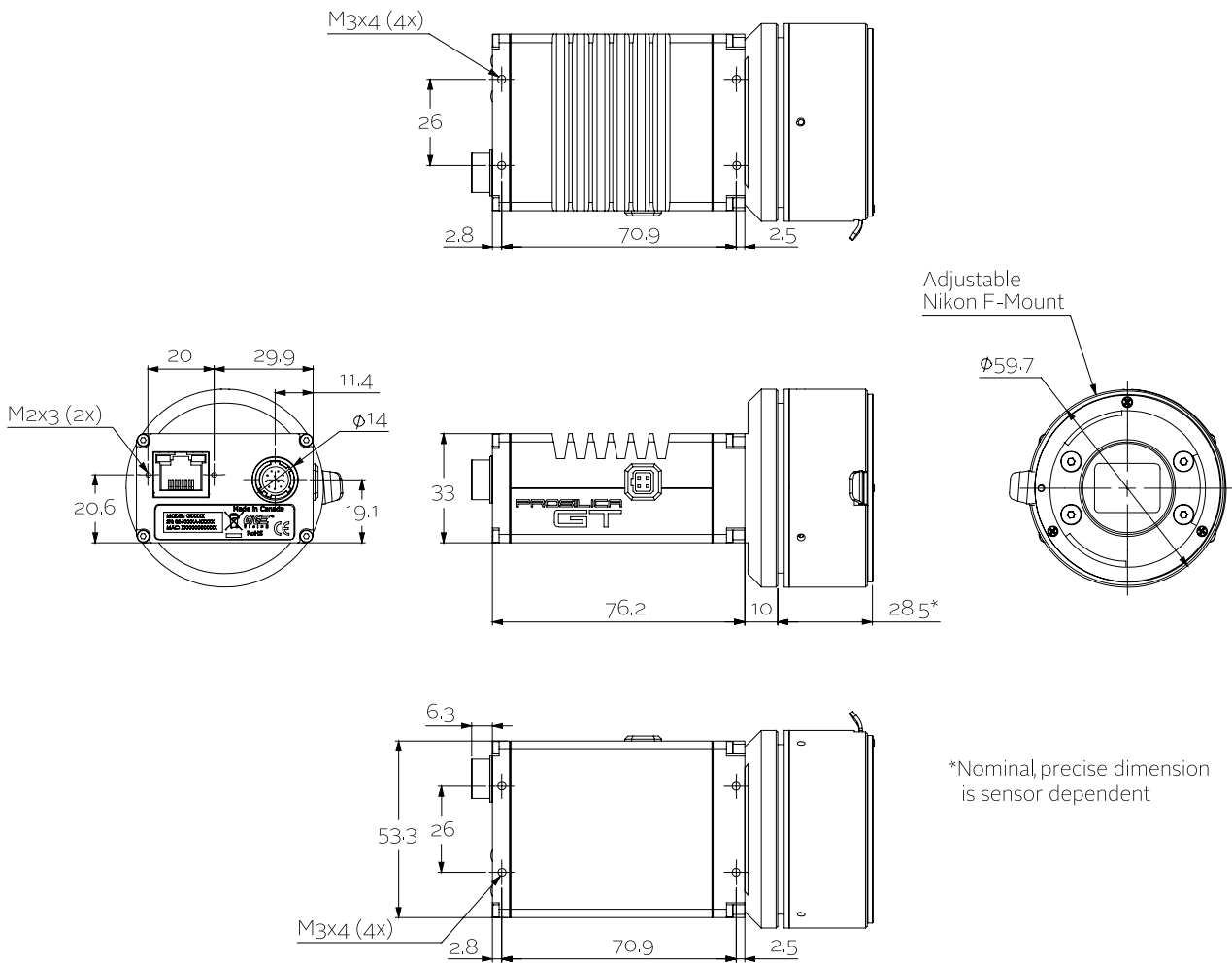

*Nominal, precise dimension is sensor dependent



Applications

Prosilica GT3300 is ideal for a wide range of applications including:

- Outdoor imaging
- Traffic imaging and Intelligent Traffic Systems (ITS)
- Public security and surveillance
- Industrial inspection
- Machine vision
- Military and space applications