



## Pike F-1600

- Versatile IEEE 1394b camera
- Advanced feature set
- Many variants
- High frame rates

### Description

16 Megapixel premium camera – 35 mm CCD sensor ON Semiconductor KAI-16000

The Pike F-1600B/F-1600C is a 16 Megapixel IEEE 1394b camera with exceptional image quality. It can be operated in either single tap or dual tap mode. At full resolution, it runs up to 3.1 frames per second (dual tap). Higher frame rates can be reached by using a smaller area of interest (AOI), binning (b/w), or sub-sampling.

Options:

- IEEE 1394b connectors: 2 x copper (daisy chain) or 1 x GOF, 1 x copper, Hirose power: out
- Various IR cut/pass filters, various lens mounts
- Angled head, white medical housing

### Specifications

Pike	F-1600
Interface	IEEE 1394b - 800 Mb/s, 2 ports, daisy chain, fiber optic (GOF) optional
Resolution	4872 (H) × 3248 (V)
Sensor	ON Semi KAI-16000
Sensor type	CCD Progressive
Sensor size	Type 35 mm
Pixel size	7.4 μm x 7.4 μm
Lens mount (default)	F-Mount
Max. frame rate at full resolution	3 fps
ADC	14 bit
Image buffer (RAM)	256 MByte

#### Output

Pike	F-1600
Bit depth	8-14 bit
Monochrome pixel formats	Mono8, Mono12, Mono16
RGB color pixel formats	RGB8
Raw pixel formats	Raw8, Raw12, Raw16
<b>General purpose inputs/outputs (GPIOs)</b>	
Opto-isolated I/Os	2 inputs, 4 outputs
RS232	1
<b>Operating conditions/dimensions</b>	
Operating temperature	+5 °C to +50 °C
Power requirements (DC)	8 V to 36 V
Power consumption	4 W (@ 12 VDC)
Mass	380 g
Body dimensions (L × W × H in mm)	142.8 × 59 × 59 (including connectors)
Regulations	CE: 2014/30/EU (EMC), 2011/65/EU (RoHS); FCC Class B

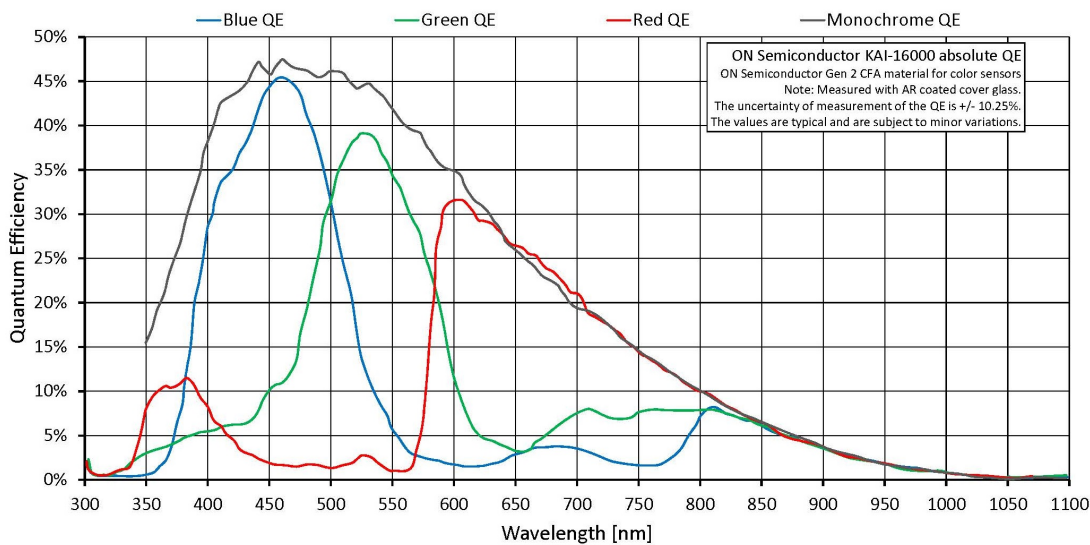

## Features

- High SNR mode (up to 24 dB better signal-to-noise ratio)
- Low-noise binning mode
- Smear reduction
- Shading correction
- Defect pixel correction

- Area of interest (AOI), separate AOI for auto features
- Binning
- Decimation
- Auto gain (manual gain control: 0 to 24 dB)
- Auto exposure (636  $\mu$ s to 67 s)
- Auto white balance
- Look-up table (LUT)
- Hue, saturation, color correction
- Reverse X
- Deferred image transport
- Trigger programmable, level, single, bulk, programmable delay
- Sequence mode (changes the camera settings on the fly)
- SIS (secure image signature, time stamp for trigger, frame count)
- Storable user sets

## Technical drawing

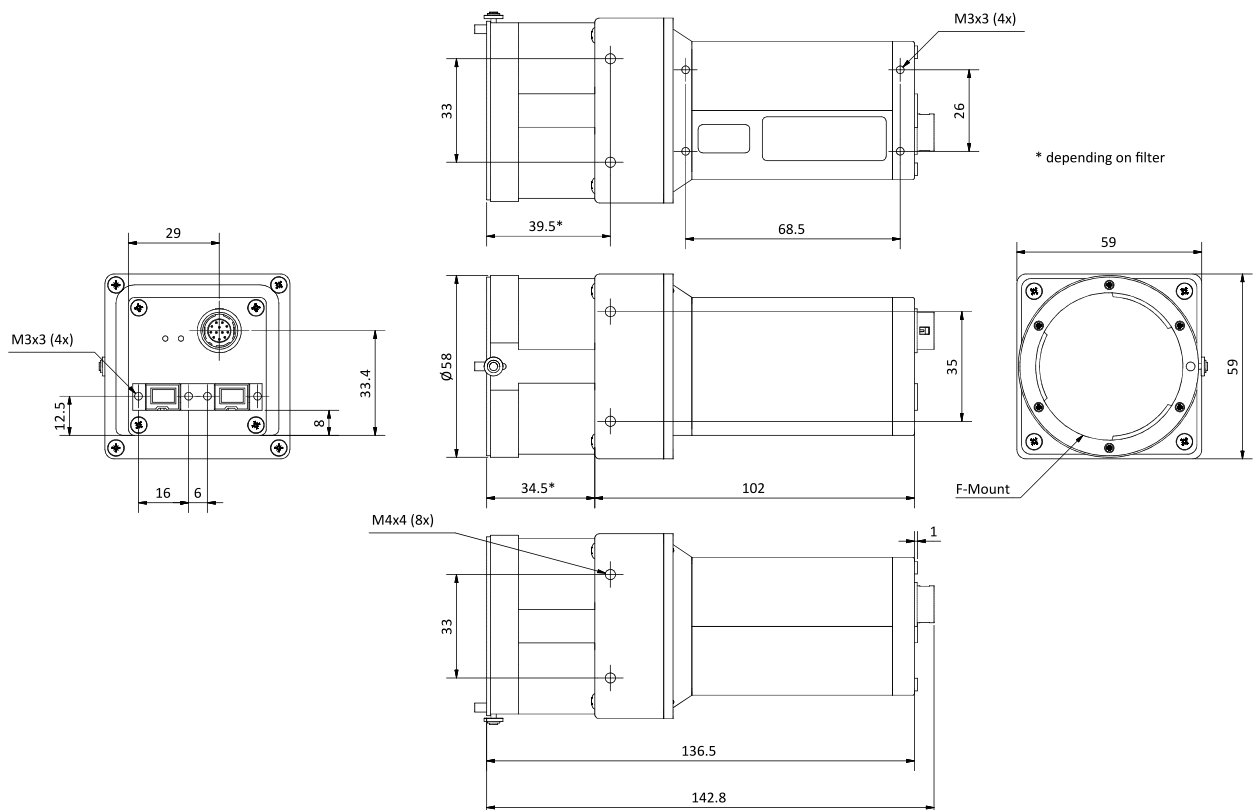



## Applications

The Pike F-1600B/F-1600C is made for high-precision applications which require highest attention to detail. Its excellent image quality can be enhanced by several image pre-processing functions. It is also available with M42-Mount or with M58-Mount.

This camera is well-suited for:

- Science and research
- Metrology
- Document scanning (replaces DSLR cameras - no mechanical shutter, long life time)
- Healthcare and medical applications
- Industrial inspection at high resolutions
- Aerial imaging
- Very demanding OEM camera applications
- Intelligent traffic solutions (ITS)
- Long cables - 400 meters and more without additional repeaters (fiber version)