

Mako U

U-503



- OnSemi (Aptina) CMOS sensor
- High frame rates
- Ultra-compact
- Extensively tested accessories

Description

Mako U-503B with CMOS ON Semiconductor (Aptina) MT9P031 sensor

Mako U-503B is a monochrome USB3 Vision camera with the ON Semiconductor (Aptina) MT9P031 CMOS sensor with rolling shutter. All Mako USB cameras have the same compact housing with a form factor of 49.5 x 29 x 29 mm. Screw locks ensure a safe electrical connection even in harsh industrial environments. Every model is powered over the USB interface and has opto-isolated I/Os. The GPIOs give Mako U maximum flexibility to adapt to specific needs. The two non-isolated GPIO lines are TTL-based and programmable as input or output.

Options:

- Various IR cut/pass filters, protection glass, various lens mounts
- White medical housing

Specifications

Mako U	U-503
Interface	USB3 Vision
Resolution	2592 (H) × 1944 (V)
Sensor	ON Semi MT9P031
Sensor type	CMOS
Sensor size	Type 1/2.5
Pixel size	2.2 μm x 2.2 μm
Lens mount (default)	C-Mount, CS-Mount
Max. frame rate at full resolution	14 fps
ADC	12 bit
Image buffer (RAM)	128 MByte

Output

Mako U	U-503
Bit depth	8/12 bit
Monochrome pixel formats	Mono8, Mono12, Mono12p
General purpose inputs/outputs (GPIOs)	
TTL I/Os	2 programmable GPIOs
Opto-isolated I/Os	1 input, 1 output
Operating conditions/dimensions	
Operating temperature	+5 °C to +45 °C (housing temperature)
Power requirements (DC)	Power over USB 3.0
Power consumption	1.9 W @ 5 VDC
Mass	60 g
Body dimensions (L × W × H in mm)	49.5 × 29 × 29 (including connectors)
Regulations	CE: 2014/30/EU (EMC), 2011/65/EU (RoHS); FCC Class B

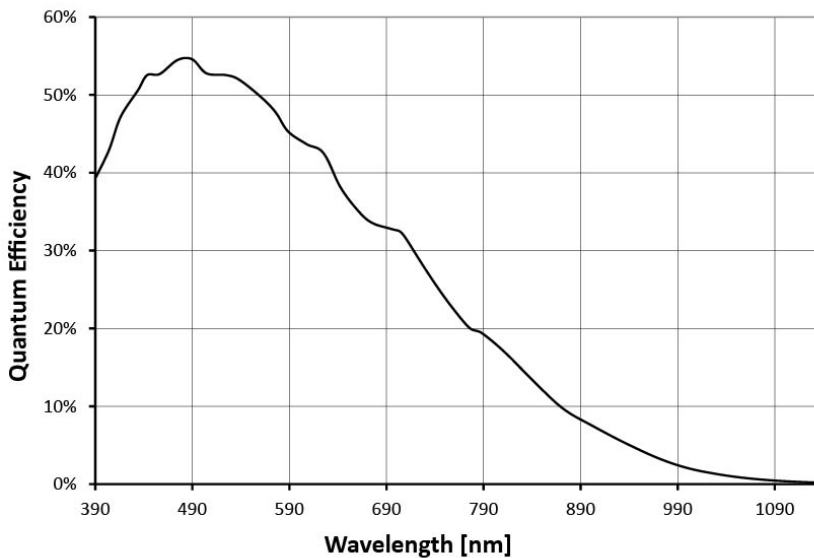

Features

- Defect pixel correction (on/off)
- Region of interest (ROI)
- Gain (manual control, 0 to 17 dB)
- Exposure (manual control, 32 μ s to 1.4 s)
- Gamma correction
- Reverse X
- DeviceLinkThroughputLimit (easy bandwidth control)

- Sync out modes: Waiting for a trigger, exposing, readout, imaging
- Storable user sets

Technical drawing

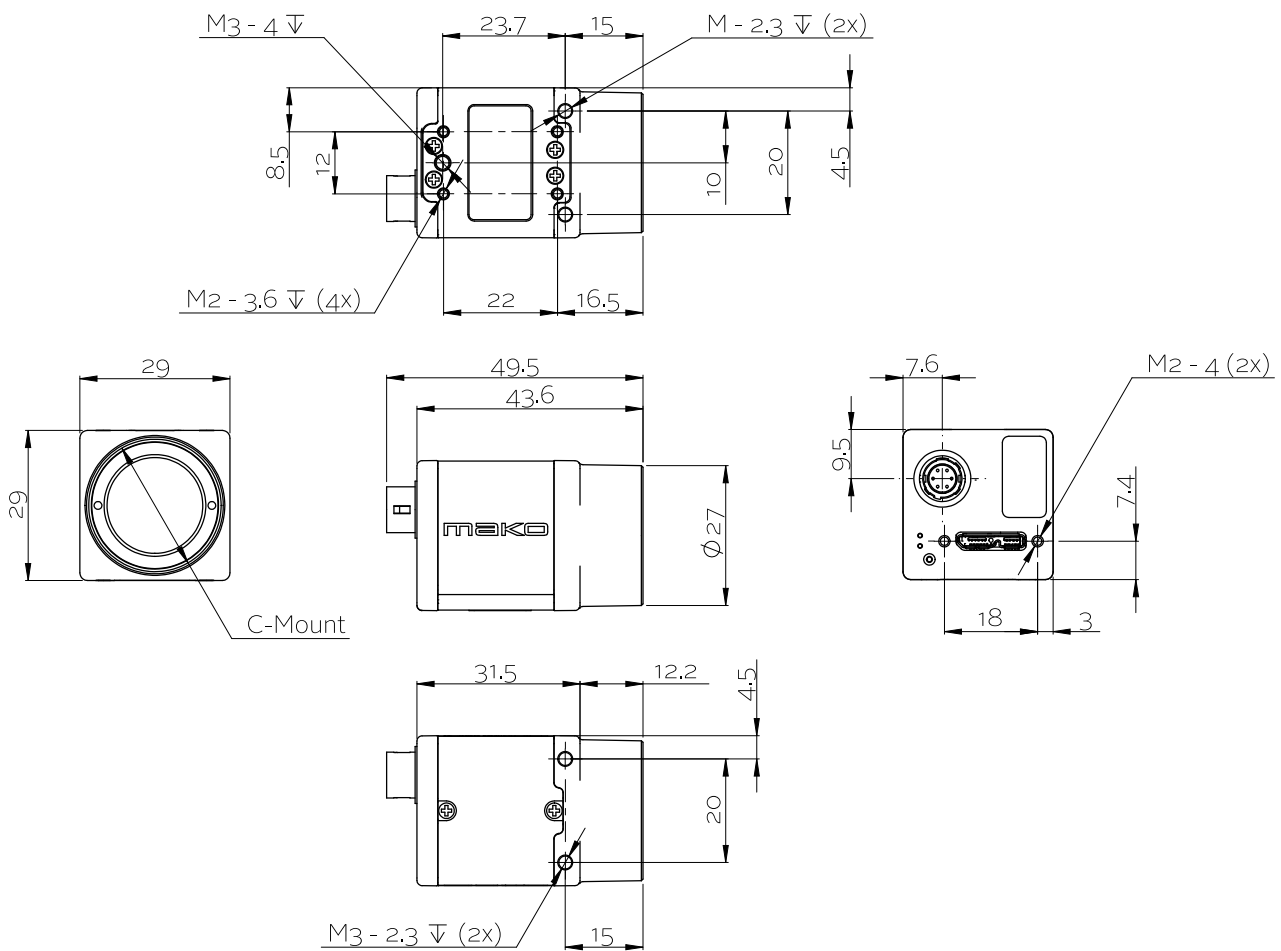



Applications

The Mako U is an inexpensive USB 3.0 camera with a compact housing. USB 3.0 technology has lower latency and jitter times with less CPU load than other camera interfaces.

Typical applications for Mako U cameras:

- Machine vision
- Quality control
- Inspection, surveillance
- Industrial imaging