

SOPHIA®-XO 2048B

SOPHIA®-XO 4096B

LARGE-FORMAT, DIRECT-DETECTION
CCD CAMERAS FOR EUV and SOFT X-RAYS





Connected Teledyne – Helping Drive Your Results

Teledyne Portfolio

Teledyne Imaging provides a collective of expertise across the spectrum. Individually, each division offers best-in-class solutions. Together, they leverage their combined strengths to provide the deepest technology portfolio in the world. From nano scales in the world of electron microscopy to space based astronomical imaging, Teledyne Imaging brings scale to the world's most difficult and demanding applications.

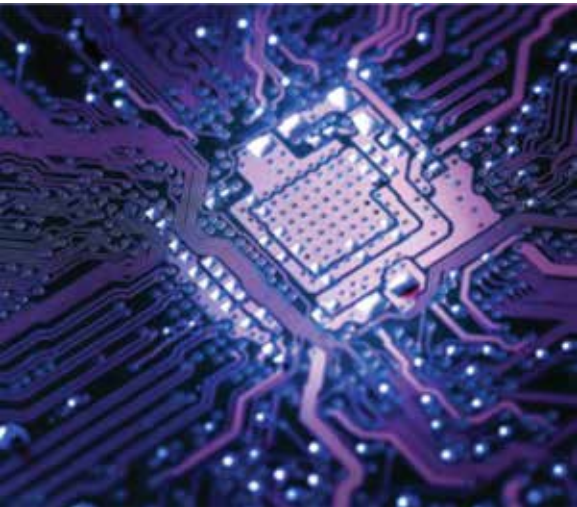

Working For You

Teledyne is committed to operational excellence at each step with involvement at every level of the supply chain – from pixel and sensor design to fabrication, systems and analysis, reducing our customer's exposure. By leveraging a continuous link to a network of engineers, we grant our customers full access to our proprietary technologies and developments, providing an optimal solution that surpasses any multi-component integration.

Partnerships

Teledyne Imaging has supported customer innovation needs for decades. Our partners are matched to a dedicated team of experts that ensure quick integration with software, optical, electrical, and mechanical elements. Additionally, the Teledyne team is in full consultation with their partners, supporting projects from start to end, with supply guarantees.



Highlights

Breakthrough Soft X-ray Performance

The SOPHIA-XO 2048B and 4096B represent the latest generation of EUV/VUV and soft x-ray direct-detection cameras:



- Back-illuminated CCD sensors with >95% QE (over ~5 eV to 30 keV range)
- 2k x 2k and 4k x 4k formats; 13.5 and 15 micron pixels
- High frame rates with up to 4-port readout
- Cooling down to -90°C using liquid or air

Applications include:

VUV/EUV/XUV Imaging | X-ray Diffraction | X-ray Microscopy | X-ray Holography
X-ray Spectroscopy | X-ray Plasma

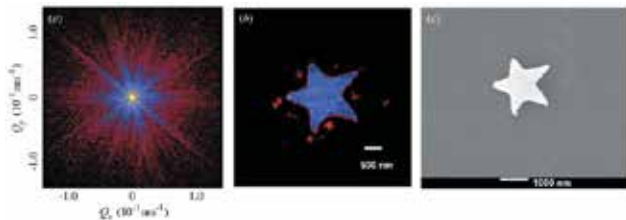

Designed for low-flux applications

SOPHIA-XO delivers optimum performance:

- Low read noise
- High QE (>95% peak)
- Wide dynamic range with up to 18-bit readout

When speed is paramount

SOPHIA-XO features the newest readout electronics:

- 1-, 2-, or 4-port simultaneous readout
- Multiple ADC speeds (up to 16 MHz)
- Binning and ROI readout
- Custom readout modes for microsecond exposures

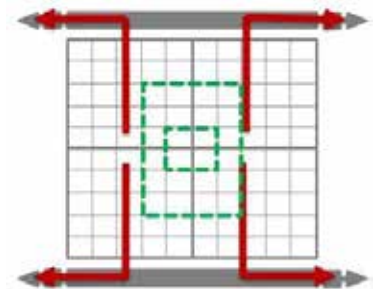

Imaging Software Flexibility

Most imaging experiments need flexibility - and the SOPHIA-XO is a perfect fit:

- Microsoft® Windows® 10 or Linux® 64-bit operating system support
- Seamless integration of controls and data acquisition into MATLAB™ (MathWorks), LabVIEW® (National Instruments), ASCOM, Maxim, DL™ (Cyanogen Imaging), and Python®
- SDK / API compatible with Microsoft Windows and Linux

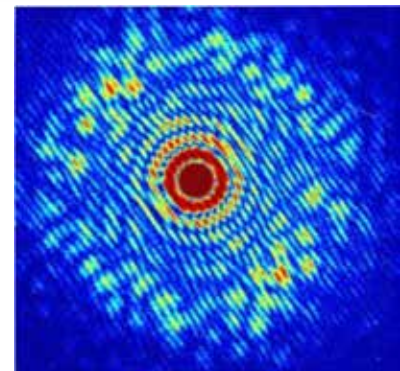
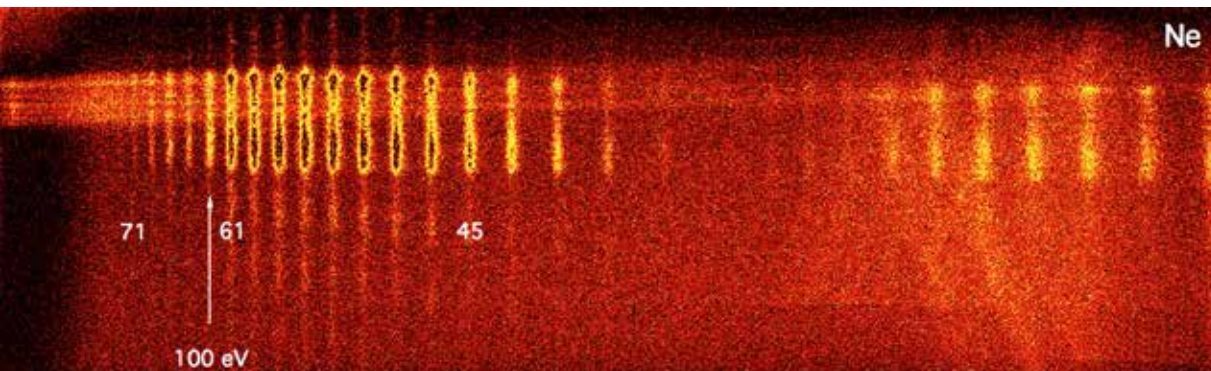

Key Camera Features

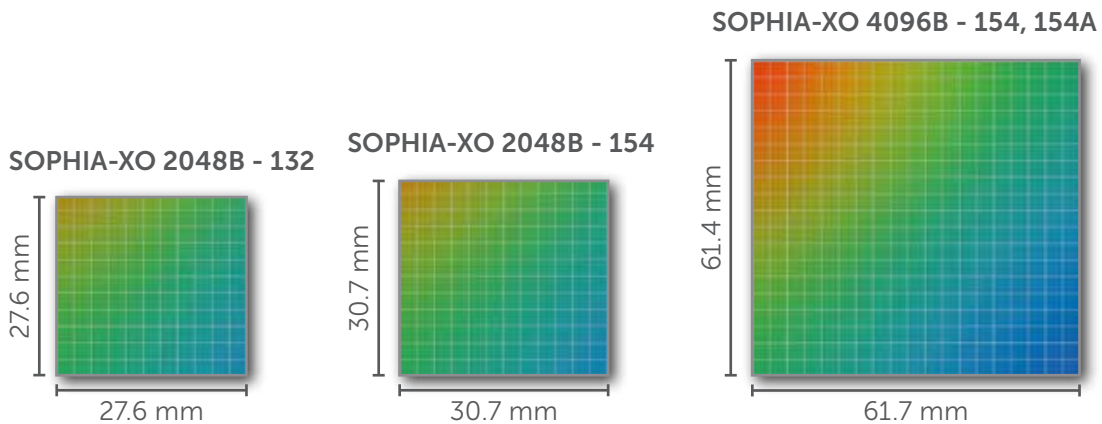

Large-format, back-illuminated 2048 x 2048 and 4096 x 4096 resolution CCD sensors with >95% peak quantum efficiency in the 5eV to 30keV range



Proprietary 4-port readout for low noise and high frame rates

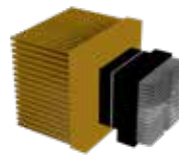

Ultra-high-vacuum, all-metal seal design for deep cooling (ArcTec™) down to -90°C



Flexibility to use air, air+liquid, or liquid cooling



The latest UHV technology with industry-standard CF flange vacuum interface (6 inch or 8 inch)

Exceptional Reliability

Princeton Instruments has been designing low-noise UV / x-ray detectors for more than three decades:

- Hundreds of cameras being used at leading laboratories around the world
- Years of trouble-free operation due to uncompromising engineering design and production
- Complete software ecosystem simplifies image acquisition and processing
- Continuous innovation to meet evolving requirements and applications

SOPHIA-XO Specifications

Feature	SOPHIA-XO 2048VUB - 132	SOPHIA-XO 2048B - 154	SOPHIA-XO 4096B - 154	SOPHIA-XO 4096B - 154A
CCD image sensor	e2v CCD42-40; UV-enhanced grade 1; NIMO; back illuminated; no AR coating	e2v CCD230-42; scientific grade 1; AIMO; back illuminated; no AR coating	e2v CCD230-84; scientific grade 1; AIMO; back illuminated; no AR coating	e2v CCD231-84; scientific grade 1; NIMO; back illuminated; no AR coating
CCD format	2048 x 2048 imaging pixels; 13.5 x 13.5 μm pixels; 100% fill factor	2048 x 2048 imaging pixels; 15.0 x 15.0 μm pixels; 100% fill factor	4096 x 4096 imaging pixels; 15.0 x 15.0 μm pixels; 100% fill factor	4096 x 4096 imaging pixels; 15.0 x 15.0 μm pixels; 100% fill factor
Imaging area	27.6 x 27.6 mm	30.7 x 30.7 mm	61.4 x 61.4 mm	61.4 x 61.4 mm
Deepest cooling temperature (@ +20°C)	< -90°C (typical) with liquid chiller; < -90°C (typical) with air	< -90°C (typical) with liquid chiller; < -90°C (typical) with air	< -90°C (typical) with liquid chiller; < -60°C (typical) with air	< -90°C (typical) with liquid chiller; < -60°C (typical) with air
Thermostating precision	$\pm 0.05^\circ\text{C}$			
Dark current (e-/pixel/sec)	0.0001	0.00025	0.005	0.8 (-60°C) 0.006 (-80°C)
Cooling method	Thermoelectric air or liquid cooling			
Full well (typical)	Single pixel: 100 ke ⁻	Single pixel: 150 ke ⁻	Single pixel: 150 ke ⁻	Single pixel: 150 ke ⁻
ADC speed	8 MHz (4 MHz x 2 ports) 2 MHz (1 MHz x 2 ports) 200 kHz (100 kHz x 2 ports)	12 MHz (3 MHz x 4 ports) 4 MHz (1 MHz x 4 ports) 400 kHz (100 kHz x 4 ports)	12 MHz (3 MHz x 4 ports) 4 MHz (1 MHz x 4 ports) 400 kHz (100 kHz x 4 ports)	12 MHz (3 MHz x 4 ports) 4 MHz (1 MHz x 4 ports) 400 kHz (100 kHz x 4 ports)
ADC bits	16 bits	16 bits	18 bits	18 bits
System read noise	3.5 e ⁻ rms @ 200 kHz 7.0 e ⁻ rms @ 2 MHz	3.5 e ⁻ rms @ 200 kHz 7.0 e ⁻ rms @ 2 MHz	3.6 e ⁻ rms @ 400 kHz 8.5 e ⁻ rms @ 4 MHz	8.0 e ⁻ rms @ 3 MHz/port; 4.0 e ⁻ rms @ 1 MHz/port; 2.0 e ⁻ rms @ 100 kHz/ port (typical)
Readout modes	2-port or 1-port readout; Kinetics; External Sync	4-port, 2-port, or 1-port readout; Kinetics; External Sync	4-port, 2-port, or 1-port readout; Kinetics; External Sync	4-port, 2-port, or 1-port readout; Kinetics; External Sync
Nonlinearity	<2% @ 100 kHz			
Software- selectable gains	1, 2, 4 e ⁻ /ADU			
Data interface	USB 3.0 (5 m interface cable provided); Optional fiberoptic interface available for remote operation			
I/O signals	Two MCX connectors for programmable frame readout, shutter, trigger in			
Software (optional)	LightField for Microsoft Windows 10 (64 bit); PICam SDK for Microsoft Windows and Linux; EPICS support via automation			
Bake-out temperature	70°C (maximum)			
Vacuum compatibility	10 ⁻⁸ Torr			
Certification	CE			
Operating environment	+5°C to +30°C non-condensing			
Camera head dimensions (L x W x H)	DN100 or 6" industry- standard CF flange: 251.6 mm (9.91") x 129 mm (5.08") x 142.8 mm (5.62")	DN100 or 6" industry- standard CF flange: 251.6 mm (9.91") x 129 mm (5.08") x 142.8 mm (5.62")	DN160 or 8" industry- standard CF flange: 251.6 mm (9.91") x 129 mm (5.08") x 142.8 mm (5.62")	DN160 or 8" industry- standard CF flange: 251.6 mm (9.91") x 129 mm (5.08") x 142.8 mm (5.62")

Specifications are subject to change

Quantum Efficiency Curves

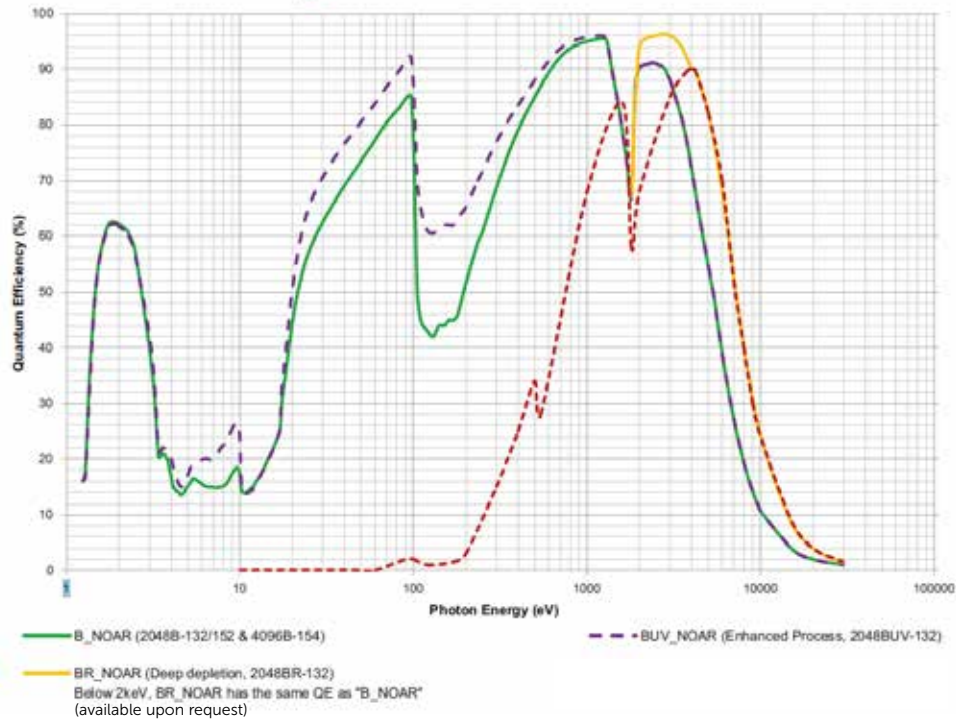

Frame Rates

SOPHIA-XO 2048B - 132

SOPHIA-XO 2048B - 154

Binning	8 MHz	2 MHz	200 kHz	Binning	16 MHz	4 MHz	400 kHz
1 x 1	1.35	0.43	0.05	1 x 1	3.2	0.9	0.09
2 x 2	2.82	1.34	0.18	2 x 2	7.4	2.9	0.33
4 x 4	3.76	2.82	0.65	4 x 4	14.3	7.7	1.05
8 x 8	4.30	3.76	1.82	8 x 8	22.2	15.4	2.9

SOPHIA-XO 4096B - 154

SOPHIA-XO 4096 - 154A

Binning	12 MHz	4 MHz	400 kHz	Binning	12 MHz	4 MHz	400 kHz
1 x 1	0.84	0.23	0.024	1 x 1	0.65	0.23	0.024
2 x 2	1.93	0.813	0.082	2 x 2	1.56	0.79	0.082
4 x 4	3.68	2.17	0.258	4 x 4	3.10	2.02	0.25
8 x 8	5.68	4.37	0.700	8 x 8	4.90	3.91	0.67

LightField® Software

The Future of Scientific Imaging and Spectroscopy Software

The combination of LightField and the SOPHIA-XO provides researchers with the most advanced and reliable toolset for experimental setup, data acquisition, and post processing:

- Powerful 64-bit software package includes Microsoft Windows 10 support
- Complete control of Teledyne Princeton Instruments cameras and spectrometers
- Dependable data integrity via automatic saving to disk, time stamping, and retention of both raw and corrected data
- Full experimental details and system settings are archived and can be reloaded for future experiments ensuring maximum reproducibility
- For light-sensitive experiments, the user interface offers “low light” and “no light” modes during data acquisition
- LightField works seamlessly in multi-user facilities, remembering each user’s hardware and software configurations
- Simple math functions and complex transforms can be applied to live or stored data, with an included easy-to-use editor to create your own formulas
- Integrated LabVIEW®, MATLAB™, Python™, ASCOM® and Maxim DL™
- Exports to your favorite file formats, including TIFF, FITS, ASCII, AVI, IGOR, and Origin
- Demo camera mode allows the user to view all of the settings and parameters associated with any camera without physically connecting the camera
- Live data processing operations provide real-time evaluation of incoming data to optimize experimental parameters

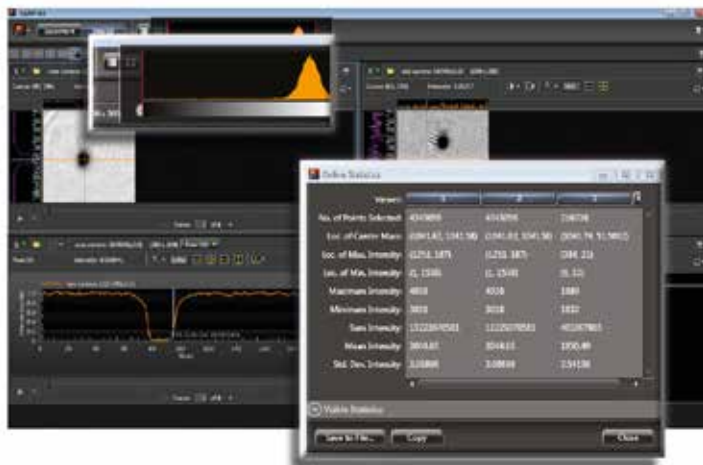

Accessories

SOPHIA-XO cameras can be provided in custom configurations to suit your experiment. Please contact your local Teledyne Princeton Instruments representative. The most common configurations are listed below:



Optional accessories

- LightField software
- PICam SDK/API for Linux and Microsoft Windows (provided for free)
- Liquid chiller
- Fiberoptic data extension cable for remote operation from up to 30 m

SOPHIA-XO 2048B Technical Drawings inches [mm]

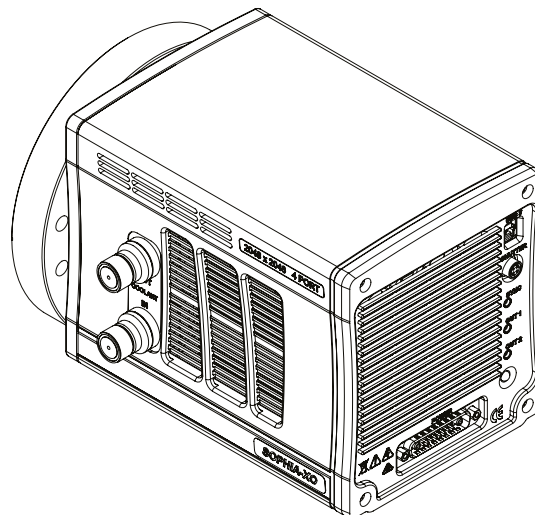
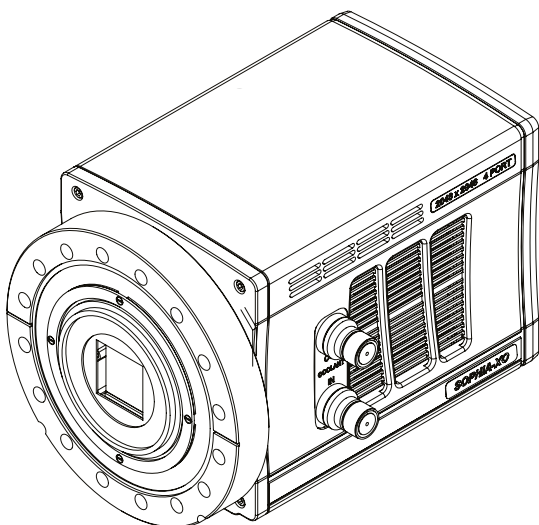
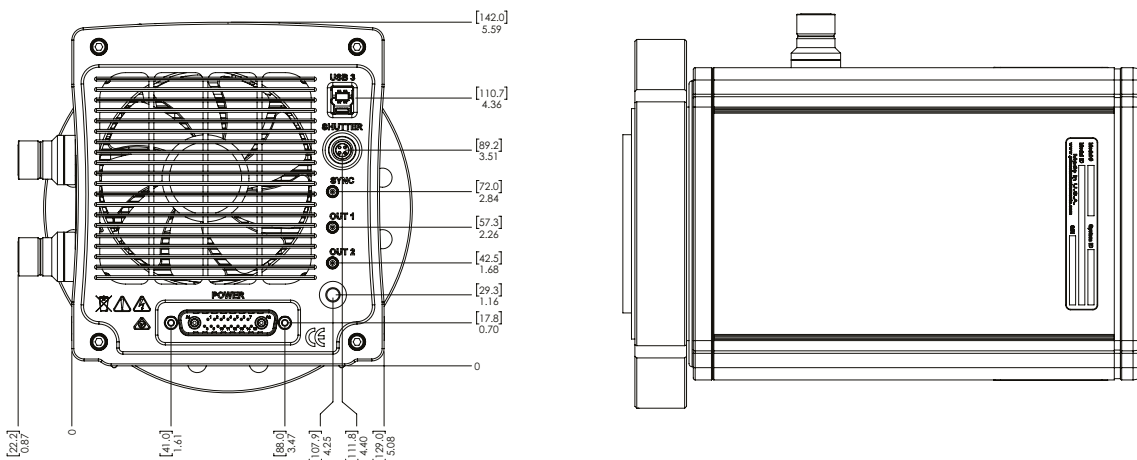
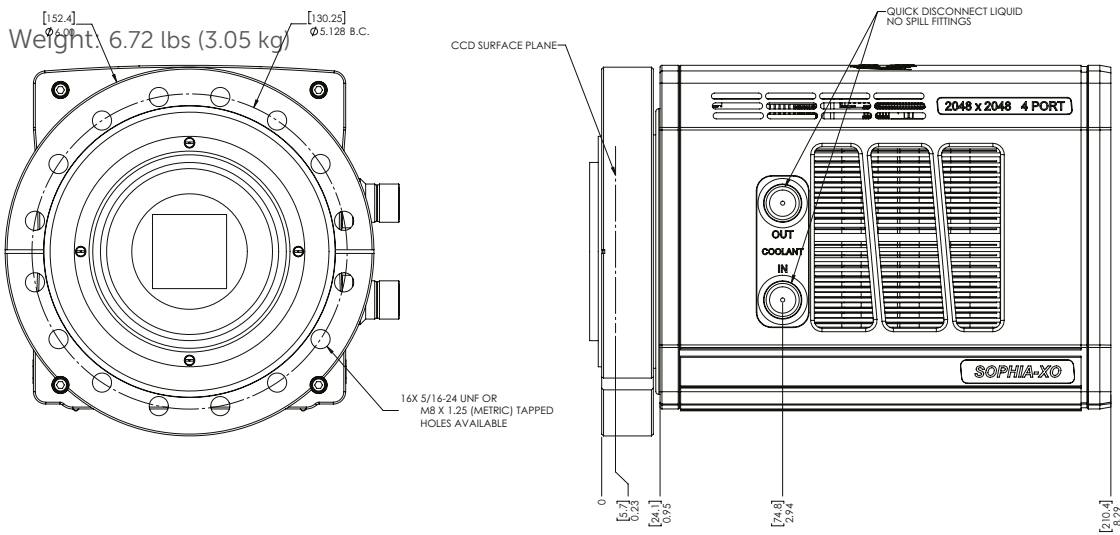

SOPHIA-XO 4096B Technical Drawings inches [mm]

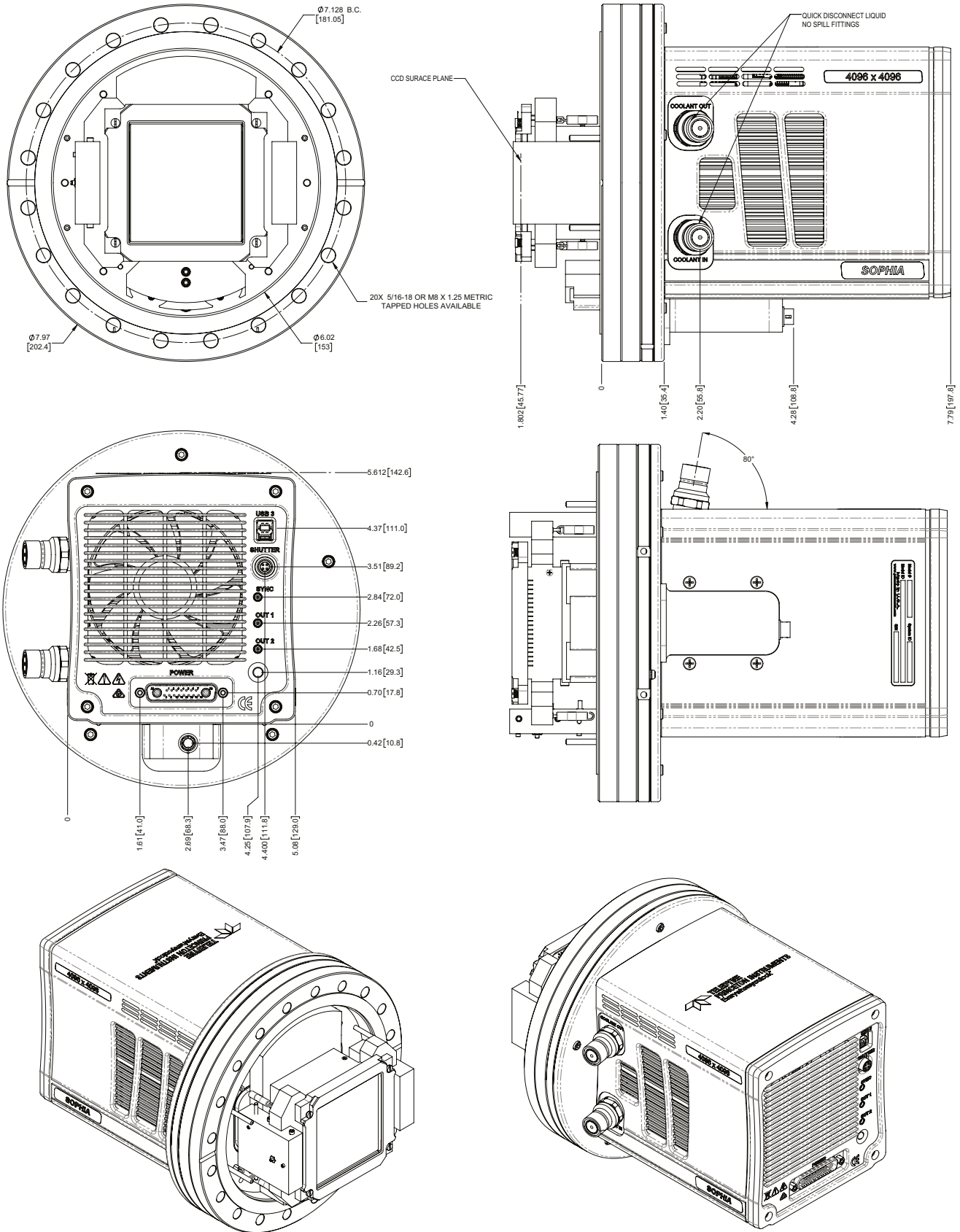

SOPHIA[®]-XO 2048B

SOPHIA[®]-XO 4096B

LARGE-FORMAT, DIRECT-DETECTION
CCD CAMERAS FOR SOFT X-RAYS



Contact your local Teledyne Princeton Instruments representative for additional information.

Teledyne Princeton Instruments – USA

Tel: +1 609.587.9797
pi.info@teledyne.com

China

Tel: +86 157 2153 5343
pi.info.china@teledyne.com

France

Tel: +33.1.70.38.19.00
evr@teledyne.com

Germany

Tel: + 49 (0) 89-660 779 3
pi.germany@teledyne.com

Japan

Tel: +81.3.6709.0631
pi.nippon@teledyne.com

United Kingdom

Tel: +44 (0) 7810 835 719
pi.info@teledyne.com

X-ray Image Credits

Page 3:

Yu et al., "Coherent X-ray scattering beamline at port 9C of Pohang Light Source II," J. Synchrotron Rad. 21, 264-267 (2014). doi: 10.1107/S1600577513025629

Page 4:

(left) Prof. Jens Biegert and Stephan Teichmann, The Institute of Photonic Science, Attoscience and Ultrafast Optics, Barcelona, Spain
(right) Dr. Jan Luning, SLAC

Copyright© 2023 Teledyne Princeton Instruments, Inc. All rights reserved. ArcTec and KURO are trademarks and SOPHIA and LightField are registered trademarks of Princeton Instruments, Inc. Microsoft and Windows are registered trademarks of Microsoft Corporation in the United States and other countries. Linux is the registered trademark of Linus Torvalds in the U.S. and other countries. Python is a registered trademark of the Python Software Foundation. All other brand and product names are the trademarks or registered trademarks of their respective owners and manufacturers.

Use and Disclosure of Data Information contained herein is classified as EAR99 under the U.S. Export Administration Regulations. Export, re-export or diversion contrary to U.S. law is prohibited.

Rev A1-03192023



Princeton Instruments
Scientific Imaging

pi.info@teledyne.com | Phone +1 609-587-9797