



# SOPHIA® 4096B

## DEEP-COOLED, ULTRA-LARGE-FORMAT CCD CAMERAS

- 4096 x 4096 sensor format
- 61.4 x 61.4 mm imaging area
- Read noise as low as 2.0 e<sup>-</sup> rms
- 18-bit digitization
- Up to 4 MHz readout (quad port)
- ArcTec™ technology for maximum deep cooling



## Connected Teledyne – Helping Drive Your Results

### Teledyne Portfolio

Teledyne Imaging provides a collective of expertise across the spectrum. Individually, each division offers best-in-class solutions. Together, they leverage their combined strengths to provide the deepest technology portfolio in the world. From nano scales in the world of electron microscopy to space based astronomical imaging, Teledyne Imaging brings scale to the world's most difficult and demanding applications.

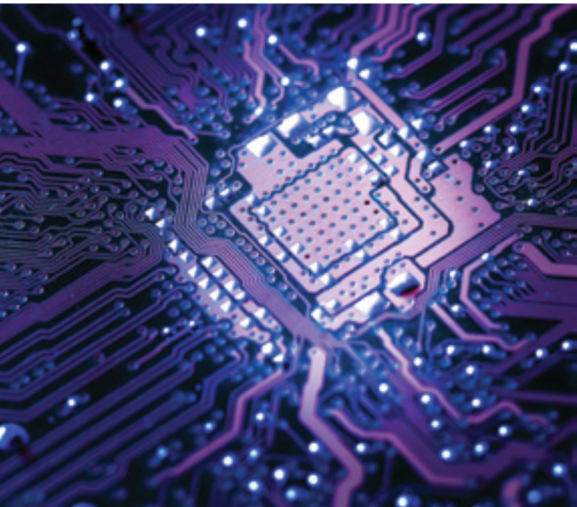

### Working For You

Teledyne is committed to operational excellence at each step with involvement at every level of the supply chain – from pixel and sensor design to fabrication, systems and analysis, reducing our customer's exposure. By leveraging a continuous link to a network of engineers, we grant our customers full access to our proprietary technologies and developments, providing an optimal solution that surpasses any multi-component integration.

### Partnerships

Teledyne Imaging has supported customer innovation needs for decades. Our partners are matched to a dedicated team of experts that ensure quick integration with software, optical, electrical, and mechanical elements. Additionally, the Teledyne team is in full consultation with their partners, supporting projects from start to end, with supply guarantees.



# Breakthrough Scientific Imaging



SOPHIA cameras are ideal for applications ranging from astronomy to fluorescence imaging.

- The SOPHIA 4096B-154 features the e2v CCD230-84 back-illuminated sensor, which provides an expansive 61.4 x 61.4 mm imaging area, 4096 x 4096 pixel resolution, and large 15  $\mu\text{m}$  pixels.
- The SOPHIA 4096B-154A model incorporates the e2v CCD231-84 "astro" back-illuminated sensor, combining exceptionally low read noise with a very large well depth.

## Key Camera Features

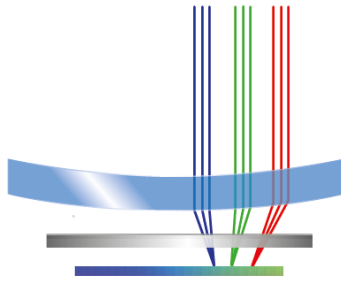

### Better Optical Design

Improved field-flattener performance with reduced window-to-CCD-surface distance along with minimized window thickness. Optimized design improves edge sharpness and lowers the distortion.

### CCD Positioning

The SOPHIA incorporates the ability to "zero out" the variability in the mechanical assembly so as to achieve precise and repeatable CCD orientation. The CCD can be adjusted for tilt, pitch, and z-axis translation, reducing the requirements for system-level adjustments.

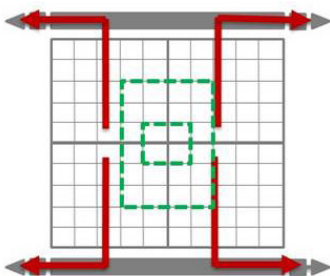
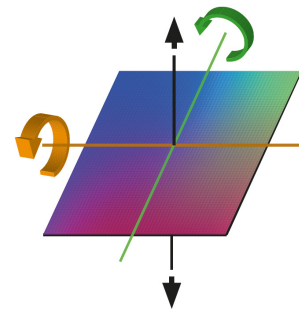

### When Speed is Paramount

SOPHIA 4096B has the most advanced readout electronics:

- 4-port simultaneous readout
- Multiple ADC speeds (up to 16 MHz)
- Binning and ROI readout
- Custom readout modes for microsecond exposures

## Large Dynamic Range

Extremely low noise, maximum well depth, 18-bit digitization, and dark current below the zodiacal photon background enable extremely long exposure times for weak-signal detection

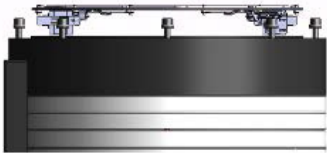
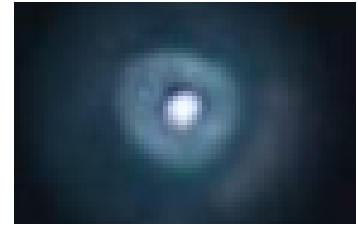

## Shutter Options

Supports an integrated high-performance 90 mm mechanical shutter or provides software control of external shutters. The integral shutter is field replaceable, reducing downtime and cost.

## Multi-TEC design with Multiple Cooling Formats

A complete redesign of the CCD cooling mechanism and vacuum chamber guarantees even heat dissipation for very large CCD formats. Designed to withstand thermal cycling and ensure repeatable CCD positioning and alignment. SOPHIA cameras reach deep temperatures without liquid nitrogen or cryocoolers, so there are no requirements for storage or bulky equipment. The SOPHIA 4096B is designed for remote operation.

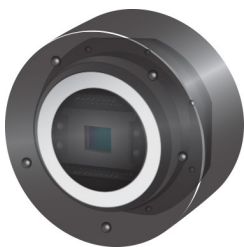
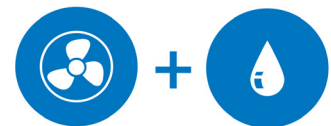
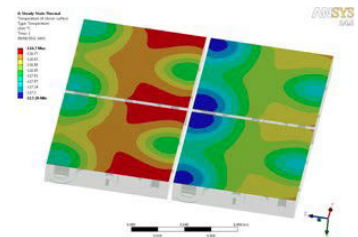

## Lifetime Vacuum Guarantee

Decades of expertise ensure the most reliable vacuum design in the industry. ArcTec™ technology utilizes an all-metal, hermetic vacuum seal with no epoxies. Teledyne Princeton Instruments is the only scientific imaging company that guarantees both cooling temperature and vacuum for the lifetime of the camera.

## Imaging Software Flexibility

The SOPHIA 4096B is a perfect solution for the most challenging low-light applications:

- Air or liquid cooling
- Microsoft® Windows® 10 or Linux® 64-bit operating system support
- Seamless integration of controls and data acquisition into MATLAB™ (MathWorks), LabVIEW® (National Instruments), ASCOM®, Maxim DL™ (Cyanogen Imaging), and Python™
- SDK / API compatible with Microsoft Windows and Linux



# Available CCD Choices

- Anti-reflection (AR) coatings on back-illuminated CCDs further improve quantum efficiency.
- Standard midband AR coating, available on the SOPHIA 4096B-154 and -154A, optimizes the response in the visible range (with QE reaching 95%).
- Deep depletion with fringe suppression and dual-AR coatings, available on the SOPHIA 4096B-154A, increases the QE response between 400 and 1000 nm, making this option an excellent choice for emerging NIR applications. Fringe suppression reduces the etaloning effect in the NIR.

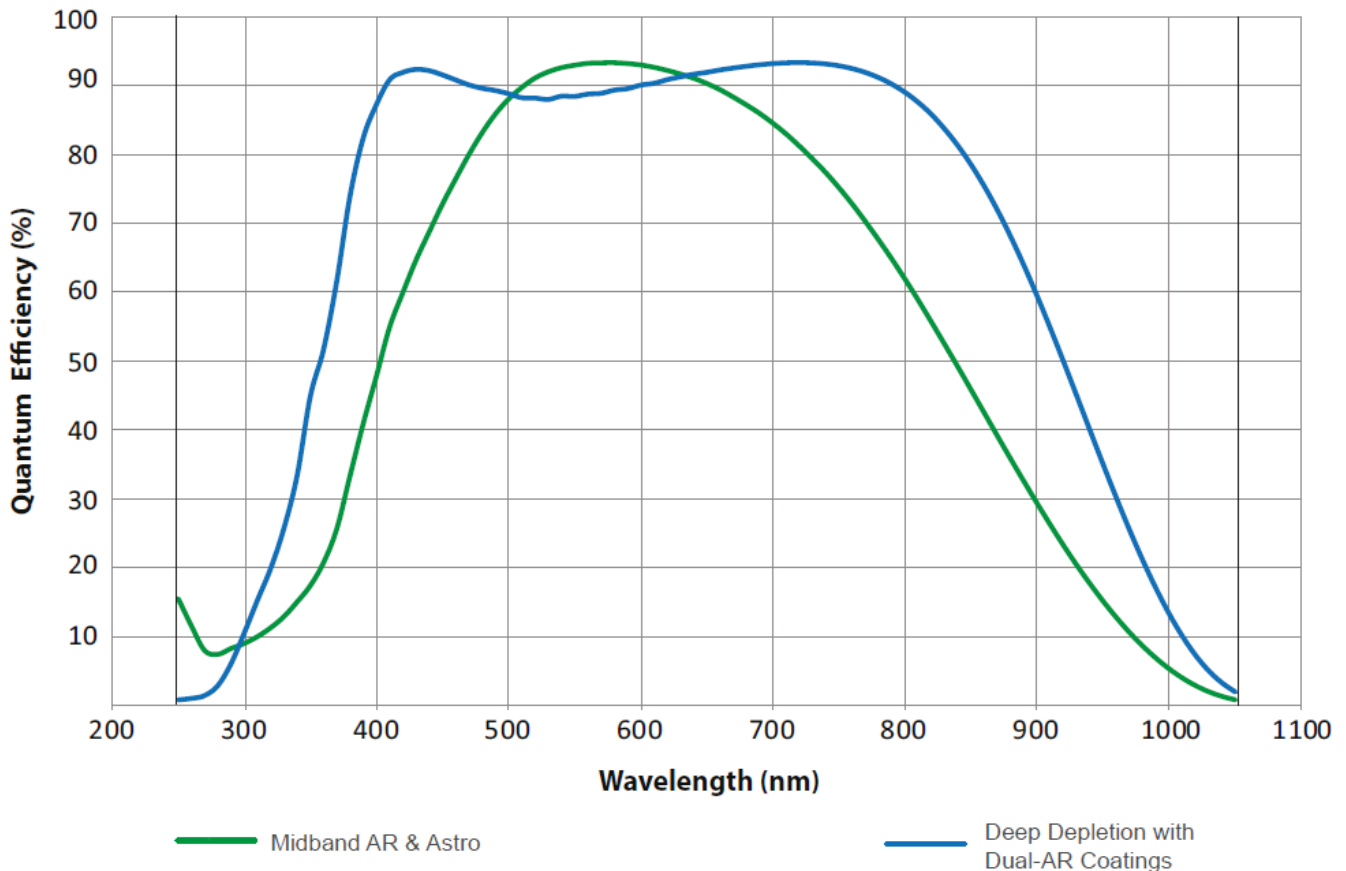

# Applications

## Astronomy

Ground-based optical astronomy covers an expansive range of scientific research. Longer exposures are common due to the faint signal of objects within space. The SOPHIA, with deep cooling down to  $-90^{\circ}\text{C}$ , has ultra-low dark noise, making it ideal for longer exposure experiments. With a peak quantum efficiency of  $>95\%$ , the SOPHIA is optimized for high sensitivity over the visible wavelength range.

The SOPHIA has a large format CCD sensor, increasing light capture and throughput. This is perfect for capturing larger objects, for enhancing object calibration by imaging more reference stars per frame, and for ultra-low light capture of faint objects. The quad-port readout architecture allows for faster readout speeds with similar read noise, for dynamic object capture. Deep-depletion technology and enhanced near infrared sensitivity, with  $>95\%$  QE over the 700-850 nm range, also makes the SOPHIA a great fit for NIR applications such as exoplanet characterization.

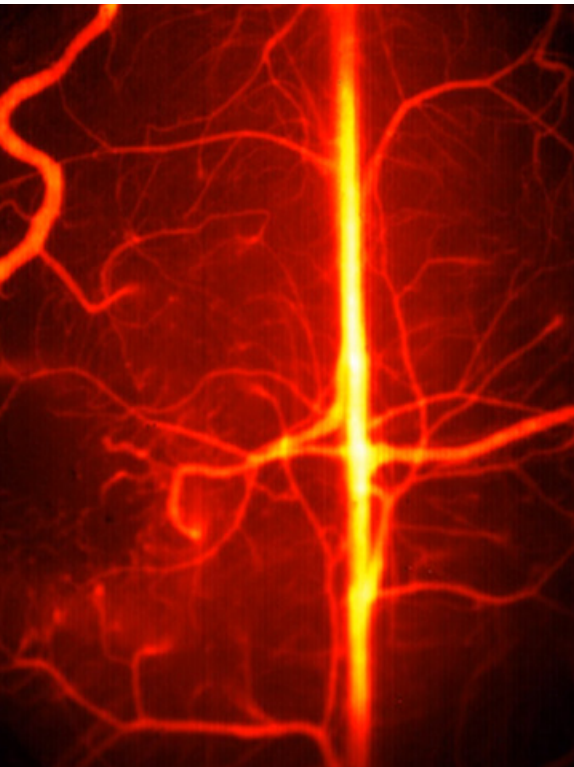

## *In vivo* imaging

Small animal research is key for translational medical research. Optical imaging detection is a common technique used within medical imaging and can provide important information for research areas such as disease detection and medicinal drug efficacy.

The SOPHIA camera has a large format CCD sensor for high throughput *in vivo* imaging over the 300 - 1000 nm range. The large field of view offers high efficiency, allowing for greater visualization of target tissue while reducing sample photodamage. As more of the sample area can be imaged, more quantitative analysis can be done on each acquired frame.

With deep cooling down, a high dynamic range and  $>95\%$  quantum efficiency, the SOPHIA is often chosen for ultra-low light imaging, common within *in vivo* studies. The low noise of the SOPHIA makes it perfect for long integration times, providing effective acquisition over a large imaging area.

## Nanotechnology Characterization

Nanotechnology encompasses a variety of research characterizing dimensions that are less than approximately 100 nanometers, including the development of faster electronics, the enhancement of biomedical imaging, and the creation of ultra-strong, extremely lightweight materials.

With a peak quantum efficiency of greater than 95% and a large format sensor for high throughput, the SOPHIA provides high sensitivity for nanoparticle detection. The large field of view offers more quantitative analysis per frame whilst deep cooling provides ultra-low dark noise, meaning longer exposures can be used for measuring extremely faint signals. Nanotechnology can be characterized via imaging and spectroscopy, each providing complementary information. The SOPHIA can be utilized for both, providing high quality acquisition regardless of technique used. The addition of eXcelon technology, with high NIR and UV quantum efficiency alongside reduced etaloning (fringing), offers better imaging and spectral quality for low-light nanoparticles in this range.

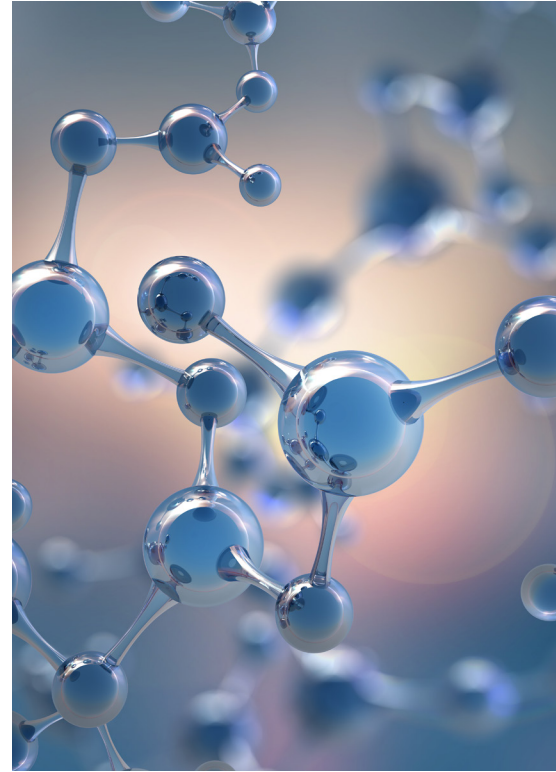



# eXcelon® Advantages

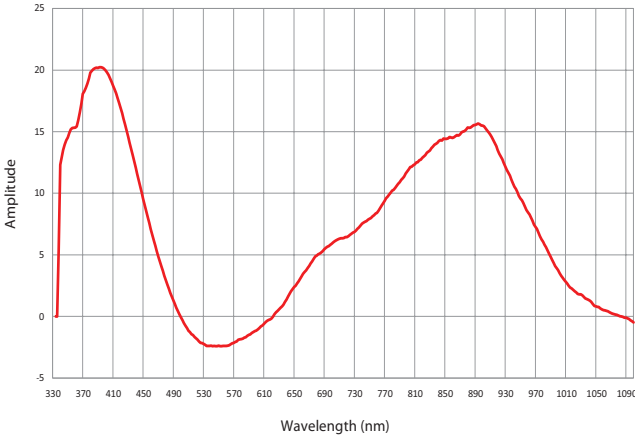

% QE Increase (eXcelon : B/I)

B\_eXcelon provides superior QE over the standard back-illuminated ("B/I") version in the UV-NIR range.

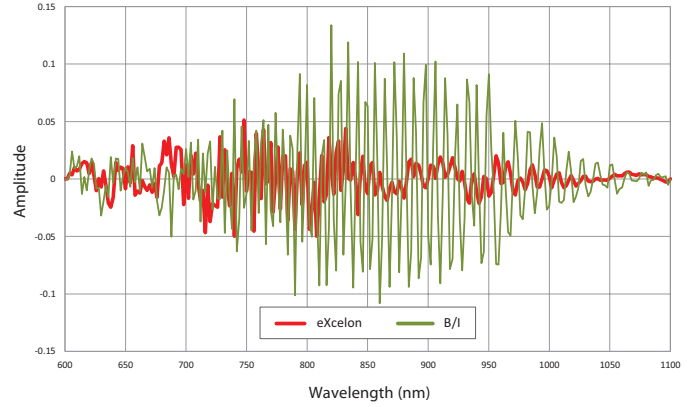

Etaloning Performance Comparison - eXcelon : B/I

B\_eXcelon provides significantly lower etaloning (unwanted fringes) compared to standard back-illuminated ("B/I") version.

## eXcelon is available as an option for most Teledyne CCD and CMOS sensors

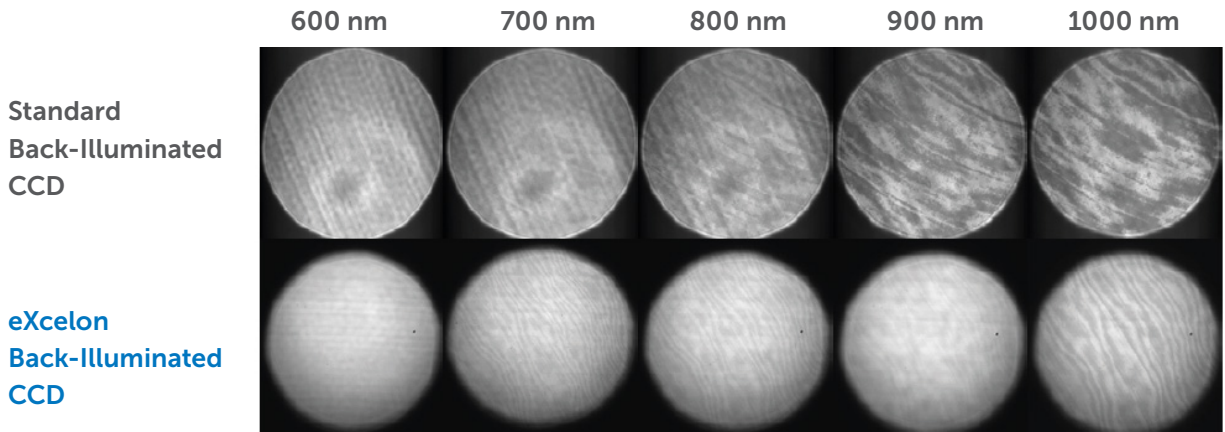

Data taken with white light source through a monochromator comparing etaloning performance of eXcelon vs. back-illuminated CCDs.

# SOPHIA 4096B Specifications

Feature	SOPHIA 4096B-154	SOPHIA 4096B-154A
CCD image sensor	e2v CCD scientific grade 1, AIMO with Teledyne e2v CCD230-84. The large image area addresses demanding scientific imaging applications. Back-illuminated spectral response and low readout noise provide outstanding sensitivity. Available with midband coating (-MB version) or eXcelon process (-X version with proprietary eXcelon).	e2v CCD scientific grade 1, NIMO, with Teledyne e2v CCD231-84. The back-illuminated "astro" version offers higher full well capacity and lower readout noise for demanding low-light applications. Astro midband (-MB version) and astro deep depletion with multiple AR coatings (-AR version) available.
CCD format	4096 x 4096 imaging pixels; 15.0 x 15.0 $\mu\text{m}$ pixels; 100% fill factor	
Imaging area	61.4 x 61.4 mm	
Deepest cooling temperature (@ +20°C)	< -90°C thermoelectric cooling with liquid chiller; < -60°C thermoelectric cooling with air	
Thermostating precision	$\pm 0.1^\circ\text{C}$	
Dark current (e <sup>-</sup> /pixel/sec)	0.0003 @ -60°C	0.8 @ -60°C
Cooling method	Thermoelectric air or liquid cooling (liquid chiller required)	
Full well	150 ke- (typical)	300 ke- (typical)
ADC speed/16 bits	3 MHz, 1 MHz, 500 kHz, 100 kHz; 4-port readout	3 MHz, 1 MHz, 500 kHz, 100 kHz; 4-port readout
ADC bits	18 bits @ 1 MHz and 100 kHz	18 bits @ 500 kHz and 100 kHz
System read noise per port	<22 e- rms @ 4 MHz/port; <8.5 e- rms @ 1 MHz/port; <4.0 e- rms @ 100 kHz/port	<8.0 e- rms @ 3 MHz/port; <4.0 e- rms @ 1 MHz/port; <2.0 e- rms @ 100 kHz/port
Readout modes	4-port, 2-port, or 1-port readout; Kinetics; External Sync	
Nonlinearity	<1% @ 100 kHz	
Software-selectable gains	1, 2, 4 e <sup>-</sup> /ADU	
Data interface	USB 3.0 (5 m interface cable provided); Optional fiberoptic interface available for remote operation	
I/O signals	Two MCX connectors for programmable frame readout, shutter, trigger in	
Software (optional)	LightField for Microsoft Windows 10 (64 bit); PICam SDK for Microsoft Windows and Linux; Automation for third-party software	
Internal shutter	90 mm mechanical shutter with internal control or TTL	
External shutter	90 mm mechanical shutter with TTL control	
Certification	CE	
Operating environment	+5°C to +30°C non-condensing	
Camera head weight	See page 12	

Specifications are subject to change

# Frame Rates (frame/sec)

## SOPHIA 4096B - 154\*

Readout Rate (MHz)	Region of Interest			
	4096 x 4096	2048 x 2048	1024 x 1024	512 x 512
4	0.44	0.66	0.88	1.05
2	0.29	0.47	0.70	0.91
1.0	0.18	0.32	0.51	0.74
0.1	0.023	0.044	0.086	0.16

## SOPHIA 4096B - 154A\*

Readout Rate (MHz)	Region of Interest			
	4096 x 4096	2048 x 2048	1024 x 1024	512 x 512
3	0.50	0.81	1.17	1.51
1	0.21	0.37	0.63	0.98
0.5	0.11	0.20	0.38	0.64
0.1	0.022	0.045	0.087	0.17

\*Frame rates calculated using 4-port readout



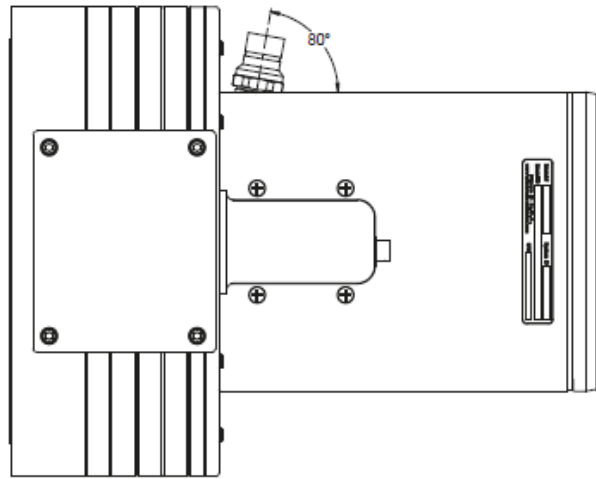
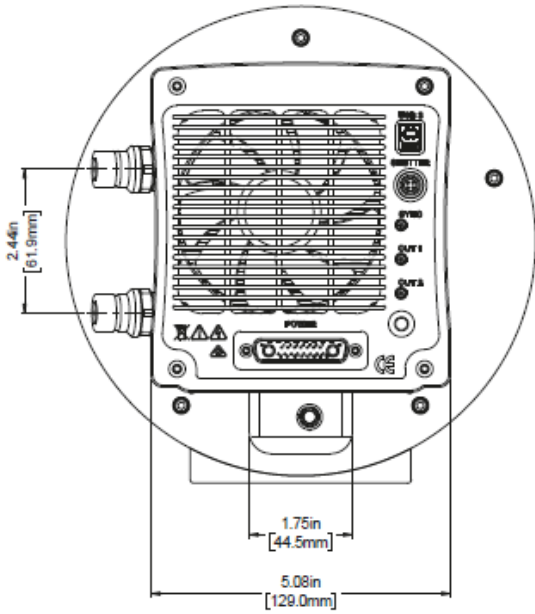
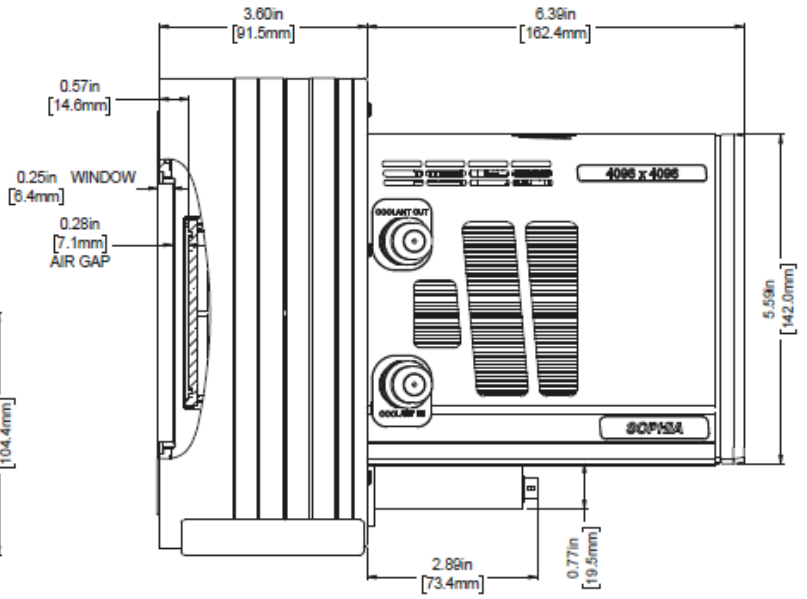
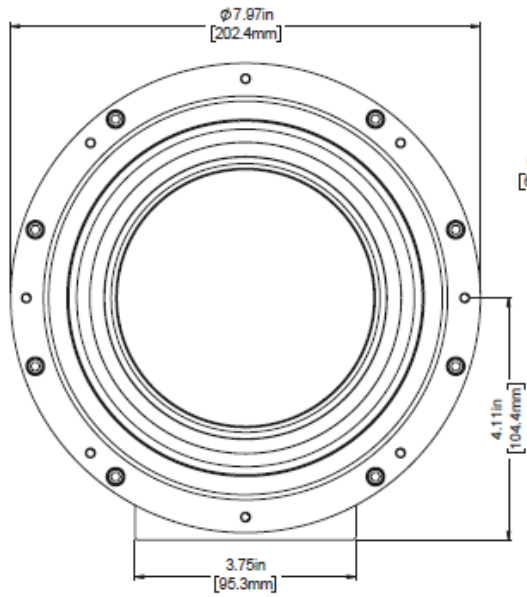

# LightField® Software

## The Future of Scientific Imaging and Spectroscopy Software

The combination of LightField and the SOPHIA 2048B provides researchers with the most advanced and reliable toolset for experimental setup, data acquisition, and post processing:

- Powerful 64-bit software package includes Microsoft Windows 10 support
- Complete control of Teledyne Princeton Instruments cameras and spectrometers
- Dependable data integrity via automatic saving to disk, time stamping, and retention of both raw and corrected data
- Full experimental details and system settings are archived and can be reloaded for future experiments ensuring maximum reproducibility
- For light-sensitive experiments, the user interface offers “low light” and “no light” modes during data acquisition
- LightField works seamlessly in multi-user facilities, remembering each user’s hardware and software configurations
- Simple math functions and complex transforms can be applied to live or stored data, with an included easy-to-use editor to create your own formulas
- Integrated LabVIEW®, MATLAB™, Python™, ASCOM® and Maxim DL™
- Exports to your favorite file formats, including TIFF, FITS, ASCII, AVI, IGOR, and Origin
- Demo camera mode allows the user to view all of the settings and parameters associated with any camera without physically connecting the camera
- Live data processing operations provide real-time evaluation of incoming data to optimize experimental parameters

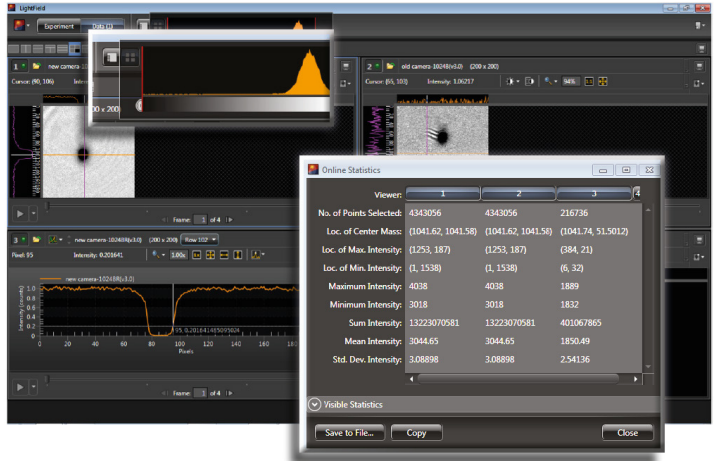

# Additional Optics & Coatings

In addition to advanced camera technology, Teledyne Princeton Instruments provides the highest performing optical components and optical subassemblies available for a diverse array of industries, including the medical, semiconductor, materials processing, analytic instrumentation, aerospace, and defense markets.

Since the 1960s, our Acton brand has become synonymous with the finest precision-engineered optics and coatings:

- UV laser optics
- Optical filters
- VUV/UV broadband optics
- CCD enhancement coatings
- Mirror blanks and windows



## Our core product competencies include:

- Excimer Laser Optics
- Excimer Laser Mirrors
- Excimer Laser Beamsplitters
- Femtosecond and Picosecond Laser Coatings
- Anti-Reflection Coatings
- UV Anti- Reflection Coatings
- Broadband Anti- Reflection Coatings
- Narrowband Anti- Reflection Coatings
- Aluminium Mirrors
- Silver Mirrors
- Gold Mirrors
- Iridium Coatings
- UV-Enhanced Mirrors
- UV-Enhanced Silver Mirrors
- Bandpass Filters
- UV Bandpass Filters
- UV Rejection Filters
- Solar Blind Filters
- Solar Blue Filters
- UV Reflective Filters
- Beamsplitters
- UV Beamsplitters
- Neutral Density Filters
- UV Neutral Density Filters
- CCD Enhancement Coatings
- Lumogen Coatings
- Metachrome® Coatings
- Filter Coatings on CCDs
- Optical Contract Manufacturing



# Accessories

SOPHIA 4096B cameras can be provided in custom configurations to suit your experiment. Please contact your local Teledyne Princeton Instruments representative. The most common configurations are listed below:



## Optional accessories and customization:

- LightField software
- PICam SDK/API for Linux and Microsoft Windows (provided for free)
- Customized coatings and filters from UV to NIR
- Custom optical assemblies

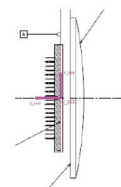
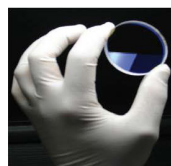
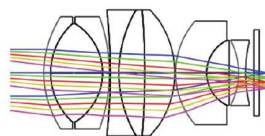

# SOPHIA® 4096B

DEEP-COOLED, ULTRA-LARGE-FORMAT CCD CAMERAS



Contact your local Teledyne Princeton Instruments representative for additional information.

**Teledyne Princeton Instruments – USA**

Tel: +1 609.587.9797  
pi.info@teledyne.com

**China**

Tel: +86 157 2153 5343  
pi.info.china@teledyne.com

**France**

Tel: +33.1.70.38.19.00  
EVR@teledyne.com

**Germany**

Tel: + 49 (0) 89-660 779 3  
pi.germany@teledyne.com

**Japan**

Tel: +81.3.6709.0631  
PI.Nippon@teledyne.com

**United Kingdom**

Tel: +44 (0) 7810 835 719  
pi.info@teledyne.com

Copyright© 2021 Princeton Instruments, Inc. All rights reserved. ArcTec and KURO are trademarks and SOPHIA, eXcelon, and LightField are registered trademarks of Princeton Instruments, Inc. Microsoft and Windows are registered trademarks of Microsoft Corporation in the United States and other countries. Linux is the registered trademark of Linus Torvalds in the U.S. and other countries. Python is a registered trademark of the Python Software Foundation. All other brand and product names are the trademarks or registered trademarks of their respective owners and manufacturers.

*Use and Disclosure of Data Information contained herein is classified as EAR99 under the U.S. Export Administration Regulations. Export, re-export or diversion contrary to U.S. law is prohibited.*



**GET IN TOUCH** to find out more  
[www.princetoninstruments.com](http://www.princetoninstruments.com)