

INSTALLATION GUIDE

ORYX[®]

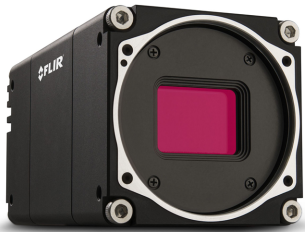

Version 5.2

Revised 11/29/2022

Oryx part numbers with 10G and 10GS are functionally the same and differ only in dimensions and mass.

FCC Compliance

This device complies with Part 15 of the FCC rules. Operation is subject to the following two conditions: (1) This device may not cause harmful interference, and (2) this device must accept any interference received, including interference that may cause undesirable operation.

Korean EMC Certification

The KCC symbol indicates that this product complies with Korea's Electrical Communication Basic Law regarding EMC testing for electromagnetic interference (EMI) and susceptibility (EMS). This equipment has received a conformity assessment for use in a business environment, and it may cause radio frequency interference if it is used in a home environment.

Hardware Warranty

The warranty for the Oryx camera is 3 years. For detailed information on how to repair or replace your camera, please see the [terms and conditions on our website](#).

Export Control

The ECCN for this product is EAR099.

WEEE

The symbol indicates that this product may not be treated as household waste. Please ensure this product is properly disposed as inappropriate waste handling of this product may cause potential hazards to the environment and human health. For more detailed information about recycling of this product, please contact us.



Trademarks

Names and marks appearing on the products herein are either registered trademarks or trademarks of FLIR Systems, Inc. and/or its subsidiaries.

Licensing

To view the licenses of open source packages used in this product please see [What open source packages does firmware use?](#)

Table of Contents

1 Oryx Installation Guide	1
2 Handling Precautions and Camera Care	2
3 Oryx Installation	3
3.1 Preparing for Installation	3
3.2 Installing Your Interface Card and Software	4
3.3 Installing Your Oryx	5
3.4 Powering Your Oryx	5
4 Tools to Control your Oryx	7
4.1 Using the Spinnaker® SDK	7
4.1.1 SpinView Camera Evaluation Application	7
4.1.2 Custom Applications Built with the Spinnaker API	7
4.2 Using GenICam Applications	8
5 Configuring Oryx Setup	9
5.1 Configuring the Camera Driver	9
5.2 Configuring the IP Address	10
5.3 Allocating Bandwidth	11
5.3.1 Determining Bandwidth Requirements	11
5.4 Configuring Other Ethernet Settings	12
5.4.1 Stream Channel Destination Address	12
5.4.2 Heartbeat	12
5.5 Oryx Firmware	13
5.5.1 Determining Firmware Version	13
5.5.2 Upgrading Firmware	13
6 Oryx Physical Interface	14
6.1 Oryx Physical Description	14
6.2 Oryx Dimensions	15
6.3 Interface Connector	18
6.4 Interface Cables	18
6.5 Interface Card	18
6.6 General Purpose Input/Output (GPIO)	18

6.7 Mounting Your Oryx	19
6.8 Camera Temperature and Heat Dissipation	19
6.9 Lens Mounting	20
6.9.1 Back Flange Distance	20
6.10 Non-Volatile Flash Memory	20
6.11 Dust Protection	20
6.12 Infrared Cut-Off Filters	21
6.13 Readout Method	22
6.13.1 Global Shutter	22
7 Input/Output Control	23
7.1 General Purpose Input/Output (GPIO)	23
7.2 GPIO Electrical Characteristics	24
7.3 Input Timing Characteristics	27
7.4 Output Timing Characteristics	29
8 Troubleshooting	31
8.1 Support	31
8.2 Status Indicator LED	32
8.3 Network Status LEDs	32
Contacting Us	33
Revision History	33

1 Oryx Installation Guide

Welcome to the Oryx camera. We offer a number of resources to assist you with the Oryx.

- **Spinnaker SDK**—software development kit that provides GenICam-compliant controls to create applications for the camera. Spinnaker is available for download. Each installation includes API documentation for C, C++, and C#.
- **Release Notes**—information about the current firmware release including feature additions or changes, bug fixes, and known issues.
- **Specifications**—information about the camera model as it performs with the current firmware.
- **Getting Started**—quick start guide for installing the camera and software.
- **Installation Guide**—information about installing the camera and SDK, the physical interface and mechanical properties, troubleshooting and how to get help. This document is available as a PDF for download or as a webpage included in the firmware release package.
- **Technical Reference**—information about the features supported by the camera model with the current firmware, including: image format control, acquisition control, sequencing, binning/decimation, and others. This document is available as a PDF for download or as a webpage included in the firmware release package.
- **Firmware**—programming inserted into the programmable ROM of the camera that can be updated in-field. New firmware packages are available for download and include both the firmware file and documentation.

These resources as well as knowledge base articles and application notes can be found on the Support page for the product.

[Oryx Support Articles](#)

[Oryx Resources](#)

2 Handling Precautions and Camera Care

Warning! Do not open the camera housing. Doing so voids the Hardware Warranty described in the [Terms and Conditions](#) on our website.

Your Teledyne FLIR machine vision camera is a precisely manufactured device and should be handled with care. Here are some tips on how to care for the device.

- Avoid electrostatic charging.
- When handling the camera unit, avoid touching the lenses. Fingerprints will affect the quality of the image produced by the device.
- To clean the lenses, use a standard camera lens cleaning kit or a clean dry cotton cloth. Do not apply excessive force.
- Extended exposure to bright sunlight, rain, dusty environments, etc. may cause problems with the electronics and the optics of the system.
- Avoid excessive shaking, dropping or any kind of mishandling of the device.

Related Knowledge Base Articles

[Cleaning the imaging surface of your camera](#)

3 Oryx Installation

3.1 Preparing for Installation

What system configuration is recommended?

	Operating System	CPU	RAM	Ports	Software to run and compile example code
Recommended System Configuration	Windows or Linux (32- or 64-bit)	Intel i7 or greater	8 GB dual channel	10GBASE-T Ethernet port	Microsoft Visual Studio 2010, Visual Studio 2013, or Visual Studio 2015

Note: Refer to [10GigE Best Practices: Setting Up a Single-camera System](#) for information on best practices for host system configuration, cabling, and Oryx camera settings.

Do you have all the parts you need?

To install your camera you need the following components:

- Ethernet cable (see [Interface Cables](#))
- GPIO cable (see [General Purpose Input/Output \(GPIO\)](#))
- Lens (see [Lens Mounting](#))
- Tripod adapter (optional) (see [Mounting Your Oryx](#))
- Interface card (see [Interface Card](#))

Teledyne FLIR sells a number of the additional parts required for installation. To purchase, visit the [Accessories page](#).

Have you visited the Teledyne FLIR website?

A downloads account is required to download software and firmware.

1. Go to www.flir.com/account.
2. Enter your email address and click Continue.
3. Complete the Create an account form and click Continue.
4. You will receive an email with a link to activate your account.
5. Once activated, you can login using the credentials you've created.

The [Oryx resources page](#) has many resources to help you operate your camera effectively, including:

- Spinnaker® SDK software, including drivers (login required)
- Firmware updates and release notes (login required)
- Dimensional drawings and CAD models
- Documentation

3.2 Installing Your Interface Card and Software

1. Install your Interface Card

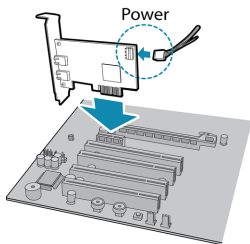

Ensure the card is installed per the manufacturer's instructions.

Connect the internal IDE or SATA power connector on the card to the computer power supply.

Alternatively, use your PC's built-in host controller, if equipped.

Open the Windows Device Manager. Ensure the card is properly installed. Ethernet cards appear under **Network Adapters**. An exclamation point (!) next to the card indicates the driver has not yet been installed.

2. Install the Spinnaker® Software

Note: For existing users who already have Spinnaker installed, we recommend ensuring you have the latest version for optimal performance of your camera. If you do not need to install Spinnaker, use SpinView to install and enable drivers for your card.

- a. Go to the [Spinnaker SDK](#) page.
- b. Click the Download button. You are prompted to login, if not already.
- c. Select your operating system. Depending on your selection there may be other versions to select.
- d. After download is complete, open the file to start the Spinnaker setup wizard.
- e. Follow the steps in each setup dialog.

3. Enable jumbo frames on the Ethernet card

- a. In **Start->All Programs-> Spinnaker SDK->SpinView**, right click on the Network Adapter and select Adapter Configuration, then select IP Configuration.
- b. Click Open Network Connections.
- c. Click Change Settings.

- d. Click on the Advanced tab and from the Settings list select Jumbo Packet.
- e. Set the Value to 9014 Bytes and click OK.

See [How to Optimize GigE Network Adapter Settings](#) for more information on configuring for best performance.

3.3 Installing Your Oryx

1. Attach a Lens

Unscrew the dust cap from the lens holder to install a lens.

2. Connect the interface Card and Cable to the Camera

Plug the interface cable into the host controller card and the camera. The cable jack screws can be used for a secure connection.

When the camera is first connected, the operating system automatically installs the camera driver. Camera drivers are available with the Spinnaker SDK installation.

3. Plug in the GPIO connector

GPIO is used for power, trigger, serial input output, and strobe.

4. Confirm Successful Installation

Run the SpinView application: **Start->All Programs-> Spinnaker->SpinView**

The SpinView application can be used to test the camera's image acquisition capabilities.

5. Configure IP Settings if necessary

By default, a dynamic IP address is assigned to the camera according to the DHCP protocol. If DHCP addressing fails, a link-local address is assigned. If necessary, in SpinView change the IP address of the camera to be on the same subnet as the NIC.

Changes to your camera's installation configuration can be made using the SpinView application.

3.4 Powering Your Oryx

Power is provided externally through the GPIO interface: 12 - 24 V. The external power supply providing 12-24 Vdc to the camera shall be certified to 60950-1 or 62368-1 with limited power source of less than 100 VA (LPS) having double/reinforced insulation to the AC mains hazardous input voltages of 100-240 Vac.

Power consumption is:

- ORX-10GS-32S4 — 11.8 W (11.3 nominal)
- ORX-10G(S)-51S5 — 12.3 W (11.7 W nominal)
- ORX-10G-71S7 — 13.6 W (13.2 W nominal)
- ORX-10G(S)-89S6 — 12.6 W (12.3 W nominal)
- ORX-10G(S)-123S6 — 13 W (12.8 nominal)
- ORX-10G-245S5 — 13.8 W (13.4 nominal)

- ORX-10G-310S9 — 13.9 W (13.6 nominal)
- 97-02800-00100 — 13 W (12.8 nominal)

The camera does not transmit images for the first 100 ms after power-up. The auto-exposure and auto-white balance algorithms do not run while the camera is powered down. It may therefore take several images to get a satisfactory image.

When the camera is power cycled (power disengaged then re-engaged), the camera reverts to its default factory settings, or if applicable, a saved user set.

4 Tools to Control your Oryx

The Oryx's features can be accessed using various controls, including:

- [Spinnaker SDK](#) including API examples
- SpinView camera evaluation application, included in the Spinnaker SDK installation
- Third-party GenICam applications

4.1 Using the Spinnaker® SDK

You can monitor or control features of the camera through Spinnaker API examples provided in the Spinnaker SDK, or through the SpinView camera evaluation application. A *Programmer's Guide and API Reference* is included in the installation.

The Spinnaker SDK is available for download from the [Spinnaker page](#).

4.1.1 SpinView Camera Evaluation Application

The SpinView application is a generic, easy-to-use streaming image viewer included with the Spinnaker SDK that can be used to test many of the capabilities of your camera. It allows you to view a live video stream from the camera, save individual images, adjust the various attributes, frame rates, features and settings of the camera. It includes tools for updating firmware, managing drivers, IP addressing, and activity logging.

4.1.2 Custom Applications Built with the Spinnaker API

The Spinnaker SDK includes a full Application Programming Interface that allows you to create custom applications to control your camera. Included with the SDK are a number of source code examples to help you get started.

Spinnaker API examples are provided for C, C++, C#, and VB.NET languages. These examples are precompiled for your convenience.

4.2 Using GenICam Applications

GigE Vision is an interface standard that allows for fast image transfer over Ethernet networks. All cameras supporting GigE Vision interact the same way with software also supporting GigE Vision.

For more information on the standard, visit visiononline.org.

The standard defines required elements for camera identification, control, and output. It uses GenICam, a programming interface for camera attribute control. GenICam allows camera vendors to define features and attributes in an XML file stored inside the camera. The file is parsed by the host application when the camera is initially discovered. One of the key benefits of GenICam is the ability for camera vendors to introduce new camera-specific features without needing to update the host application.

Each camera attribute, such as exposure time, is controlled by a specific GenICam feature. The camera includes an XML device description file for interfacing with third-party GenICam-compliant APIs.

For more information on GenICam, visit emva.org.

Getting Started with Third-Party Applications Resources

Title

[Getting Started with OpenCV](#)

[Getting Started with MATLAB](#)

[Getting Started with MVTec HALCON](#)

[Getting Started with Cognex VisionPro](#)

[Getting Started with Adaptive Vision](#)

[Getting Started with Matrox Imaging Library](#)

[Getting Started with Matrox Design Assistant](#)

[Getting Started with NI-MAX and LabVIEW](#)

[Getting Started with NI Vision Builder for Automatic Inspection](#)

5 Configuring Oryx Setup

After successful installation of your camera and interface card, you can make changes to the setup. Use the tools described below to change the IP Address or the driver for your interface card.

For information on updating your camera's firmware post installation, see [Oryx Firmware](#).

5.1 Configuring the Camera Driver

For the Oryx camera, ensure that PGRLWF driver version 2.7.3.92 or above is installed.

The PGRLWF driver should already be installed automatically using the Spinnaker SDK installer when the Camera Evaluation option is selected. Or in the case of Application Development option, the driver is installed if you select the GigE Driver checkbox.

Alternatively, you can manually install the driver. The PGRLWF files are located in:
 C:\Program Files\FLIR Systems\Spinnaker\driver64

To verify your driver:

1. Launch SpinView:

Start-->All Programs-->Spinnaker SDK-->SpinView

2. Select the camera.

3. In the Feature tree search box, enter "driver". The Device Driver Version feature is highlighted.

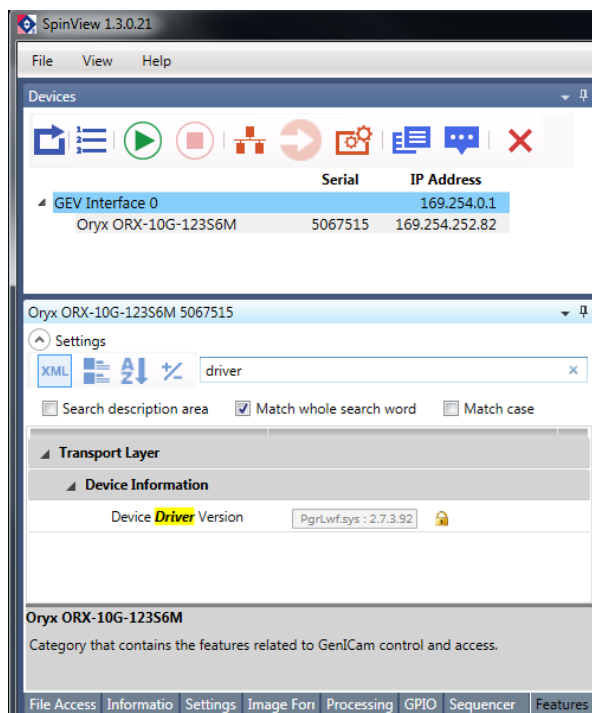

4. If you need to update the driver, right-click on the device and select Filter Driver Configuration.

- In the Filter Driver Configuration window, ensure the driver is installed and enabled. Click Refresh if making changes.

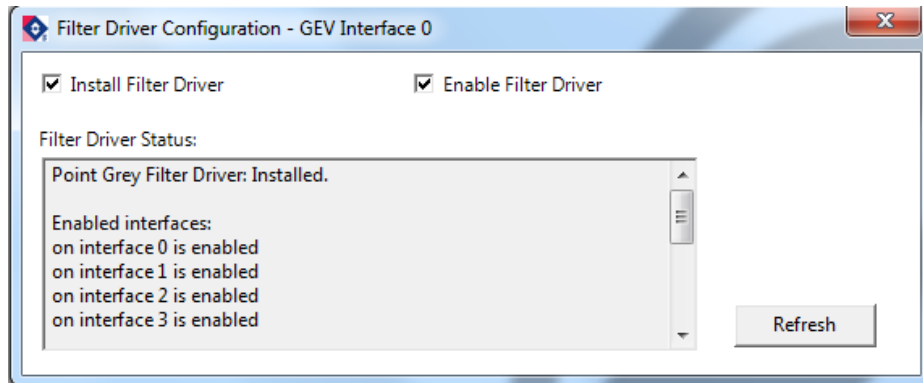

Note: If the filter driver is not installed, a caution icon appears next to the device. Right-click on the device and select GigE Filter driver is not installed-->Install filter driver to resolve.

5.2 Configuring the IP Address

When a new GigE camera is first powered and initialized, a dynamic IP address is assigned to the camera according to the DHCP protocol. If DHCP addressing fails, a link-local address is assigned. You can configure the IP address using the GenICam Features Transport Layer Control.

Alternatively, SpinView is a tool included with the Spinnaker SDK that allows you to set the internet protocol (IP) configuration for any GigE interface cards or Teledyne FLIR GigE Vision cameras connected to your system. Using SpinView, you can:

- Set the IP address for the current connection.
- Program a persistent IP address for the camera.
- Configure the default IP addressing behavior of the camera on startup using a persistent IP, DHCP or LLA.
- Enable Jumbo Frames on the GigE NIC.

Both your camera and host adapter must have an IP address on the same subnet. This can be assigned in three ways:

- Persistent**—The camera has a fixed IP address that does not change. Generally the address is within a closed network range of 192.168.X.X.
- Dynamic (DHCP)**—The camera is set to automatically obtain an IP address. This means that the IP address may change (within a range) every time the camera or computer is restarted. It may take up to one minute for the IP address to resolve and the camera to enumerate.
- Default (LLA)**—The camera uses an IP address from the link-local address block 169.254.x.x.

The camera assigns its current IP address in the following sequence:

1. **Persistent**—Uses the defined IP address. If not available, then;
2. **DHCP**—Attempts to find a dynamic IP address. If not available, then;
3. **LLA**—Uses an LLA IP address.

SpinView can automatically force an IP address refresh. This detects the IP address of the Network Interface card and automatically sets the camera's IP address relative to the card.

To open SpinView:

Start Menu > All Programs > Spinnaker SDK > SpinView

5.3 Allocating Bandwidth

The User Datagram Protocol (UDP) used by the GigE Vision standard provides no guaranteed transmission or fixed timing mechanism. Therefore, bandwidth must be managed by the Device Throughput Limit, based on desired resolution and frame rate.

5.3.1 Determining Bandwidth Requirements

The maximum bandwidth available is 1250 MB/s. This includes image data, control data and image resends, which occur when frames are being dropped. Each image and each packet has a certain amount of overhead that will use some bandwidth. Therefore, when calculating your bandwidth requirements, you should not attempt to use the full maximum of 1250 MB/s.

To calculate your bandwidth requirements:

Determine your required resolution, frame rate, and pixel format (bytes per pixel)

$$(\text{Height} \times \text{Width} \times \text{Frame Rate} \times \text{Bytes per Pixel}) / 1000000 = \text{Bandwidth in MB/s}$$

For example, for an image that is 4096 × 2160, 93 FPS, Mono8:

$$4096 \text{ (H)} \times 2160 \text{ (W)} \times 93 \text{ (FPS)} \times 1 \text{ (BPP)} = \sim 823 \text{ MB/s}$$

Once you have calculated your required bandwidth, you can allocate an amount to each camera by adjusting the Device Throughput Limit. Allocating a specific amount to each camera helps to avoid dropped packets due to a data burst. You would do this in a set up with multiple cameras, or in a situation where the system bandwidth might be limited or shared due to hardware architecture.

Bandwidth Requirements for Multiple Cameras

Multiple cameras can be set up in two ways: 1) Each camera is connected directly to a single Ethernet port; or, 2) multiple cameras are connected to a single port through an Ethernet switch.

If using the first method, each camera has the full bandwidth allocation available to it. If using the second method, the combination of all cameras on a switch cannot exceed the available bandwidth.

Related Knowledge Base Articles

[Setting Up Multiple GigE Cameras](#)

5.4 Configuring Other Ethernet Settings

5.4.1 Stream Channel Destination Address

The stream channel destination address (SCDA) register is used to specify the streaming destination IP address. The default SCDA is the IP address of the network or computer to which the camera is connected. It can be set within a range so that the camera sends data as a multicast. As long as switches in the path between the sender and receivers support and are configured for multicasting, multiple receivers can listen to the data stream from the camera.

Multicast addresses are between 224.0.0.0 and 239.255.255.255.

Note: For more information on multicast address assignments, see <http://tools.ietf.org/html/rfc3171>

To control SCDA use:

- GenICam—GevSCDA in the Transport Layer Control

5.4.2 Heartbeat

The heartbeat is a mandatory GigE Vision feature to monitor the connection between an application and the camera. The application must continually reset the heartbeat timer, or the camera assumes an error has occurred and shuts down the connection.

In general, the Spinnaker API manages the heartbeat at a low level; however the following two features are controllable: Heartbeat Timeout and Heartbeat Disable.

Heartbeat Timeout

Heartbeat timeout is the time, in milliseconds, that the camera waits before closing the connection. Heartbeat timeout can be set between 500 ms and 10 seconds. The default setting is 3000 ms (3 seconds). If there is no communication between the camera and the application for longer than the timeout value, the connection is shut down.

To control Heartbeat Timeout use:

- GenICam—Under Transport Layer Control, `GevHeartbeatTimeout`.
- Spinnaker API—The Spinnaker SDK supports configuring heartbeat timeout.

Heartbeat Disable

The heartbeat is enabled by default.

To disable Heartbeat use:

- GenICam—Under Transport Layer Control `GevGVCPHeartbeatDisable`.
- Spinnaker API—The Spinnaker SDK supports disabling heartbeat.

5.5 Oryx Firmware

Firmware is programming that is inserted into the programmable read-only memory (programmable ROM) of most Teledyne FLIR cameras. Firmware is created and tested like software. When ready, it can be distributed like other software and installed in the programmable read-only memory by the user.

The latest firmware versions often include significant bug fixes and feature enhancements. To determine the changes made in a specific firmware version, consult the Release Notes.

Firmware is identified by a version number, a build date, and a description.

5.5.1 Determining Firmware Version

To determine the firmware version number of your camera:

- Query the GenICam Device Control feature DeviceFirmwareVersion.

5.5.2 Upgrading Firmware

Firmware can be upgraded or downgraded to later or earlier versions using SpinView, part of the Spinnaker SDK.

Before upgrading firmware:

- Install the **Spinnaker SDK**, available from the [Spinnaker page](#).
- Download the latest **model package** zip file for the product, available from the camera's resources page:

[ORX Camera Resources](#)

To upgrade the firmware:

1. **Start Menu-->All Programs--> Spinnaker SDK-->SpinView**
2. From the Device list, right click the camera and select Update Device Firmware.
If you get a Device is Active warning, close the Display pane or click the Disconnect button and right click the camera again.
3. Browse to select the firmware file and click Open.
4. Click Yes to continue.

Warning! Do not disconnect the camera during the firmware update process.

Related Knowledge Base Articles

[Teledyne FLIR machine vision software and firmware version numbering systems](#)

[Determining my camera's firmware version](#)

[Should I upgrade my camera firmware or software?](#)

6 Oryx Physical Interface

6.1 Oryx Physical Description

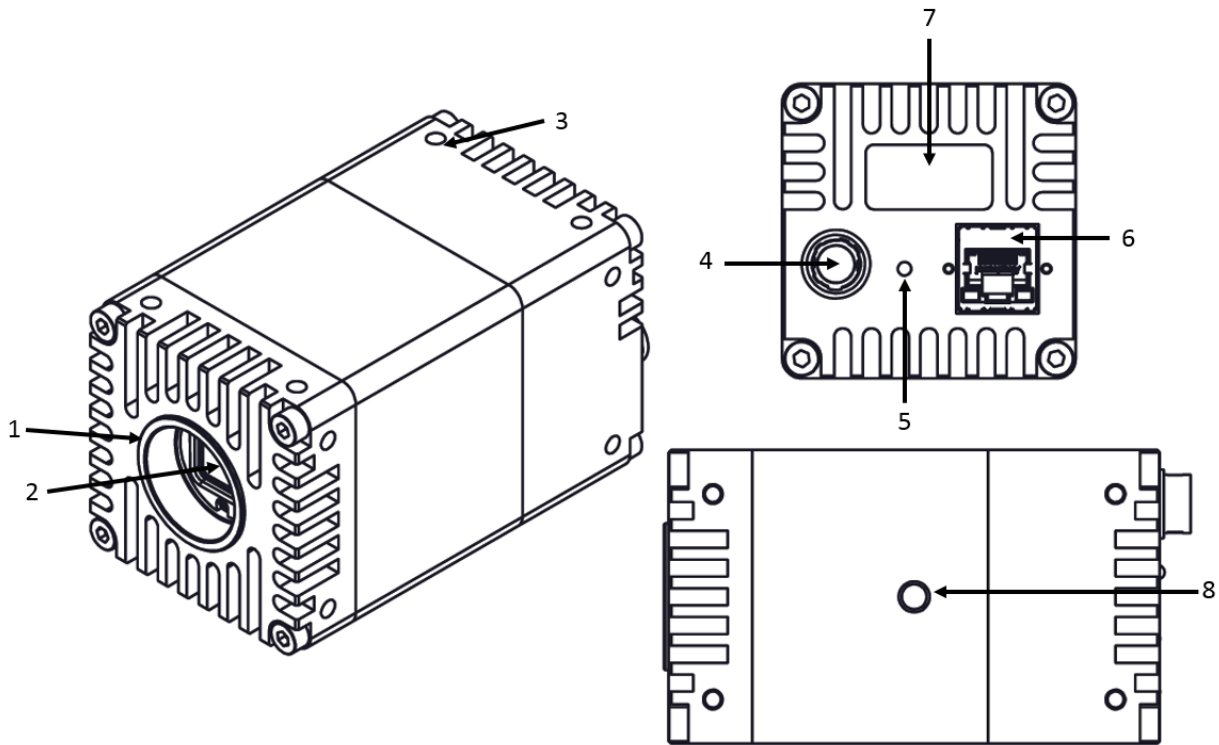

1. Lens holder

See [Lens Mounting](#)

2. Glass/IR filter system

See [Dust Protection](#) and [Infrared Cut-Off Filters](#)

3. M4.OXO.7 mounting holes (x16)

See [Mounting Your Oryx](#)

4. General purpose I/O connector

See [General Purpose Input/Output \(GPIO\)](#)

5. Status LED

See [Status Indicator LED](#)

6. Interface connector

See [Interface Connector](#)

7. Camera label

Contains camera information such as model name, serial number and required compliance.

8. 1/4-20 mounting hole (standard and large case only)

See [Mounting Your Oryx](#)

6.2 Oryx Dimensions

Download 3D CAD Models / Drawings:

[ORX CAD Models](#)

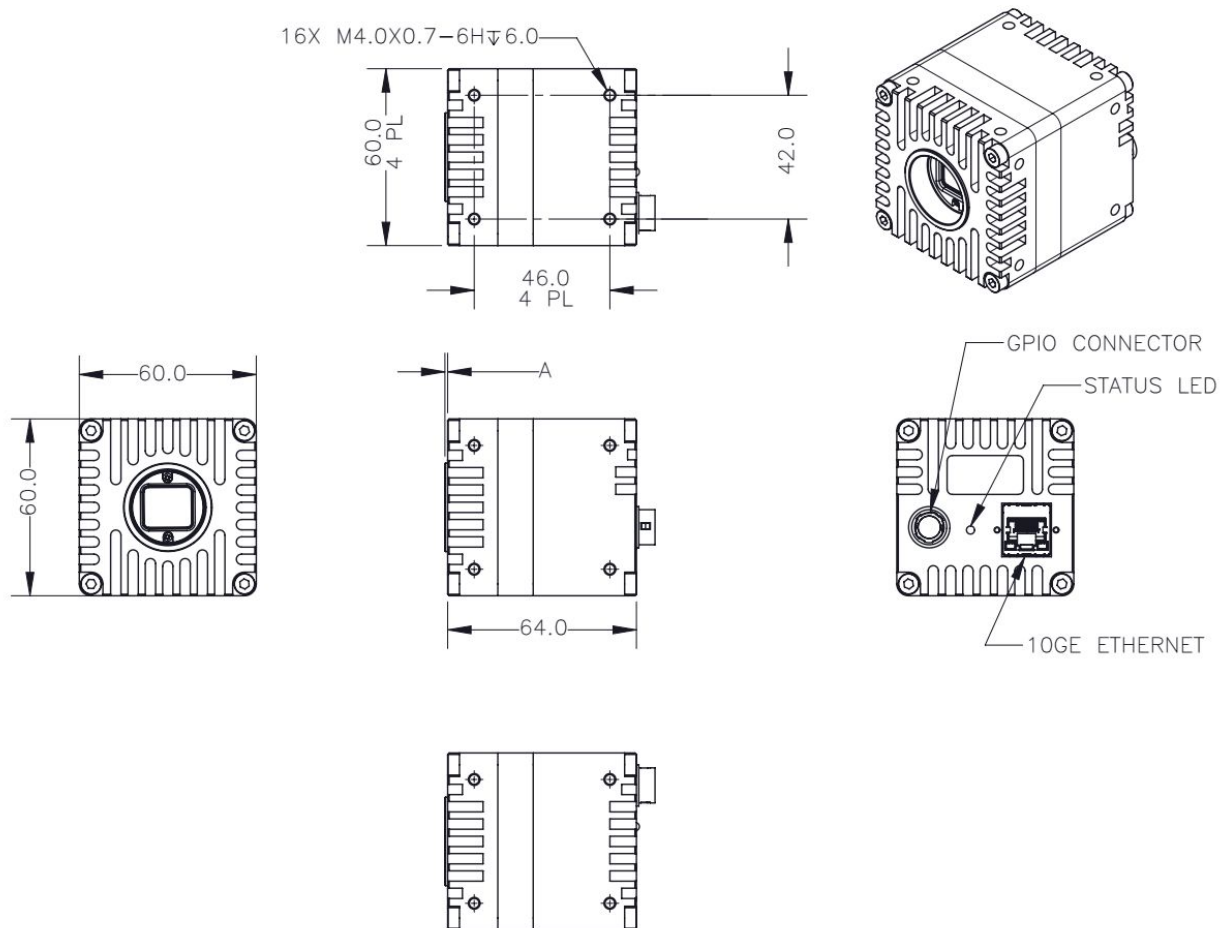

Oryx Dimensional Drawing—Small Format

Small Case Models	Barrel Length "A" (+0.1/-0.3)
ORX-10GS-32S4	0.9
ORX-10GS-51S5	0.9
ORX-10GS-89S6	0.9
ORX-10GS-123S6	0.9

Note: the small format does not have a 1/4-20 mounting hole

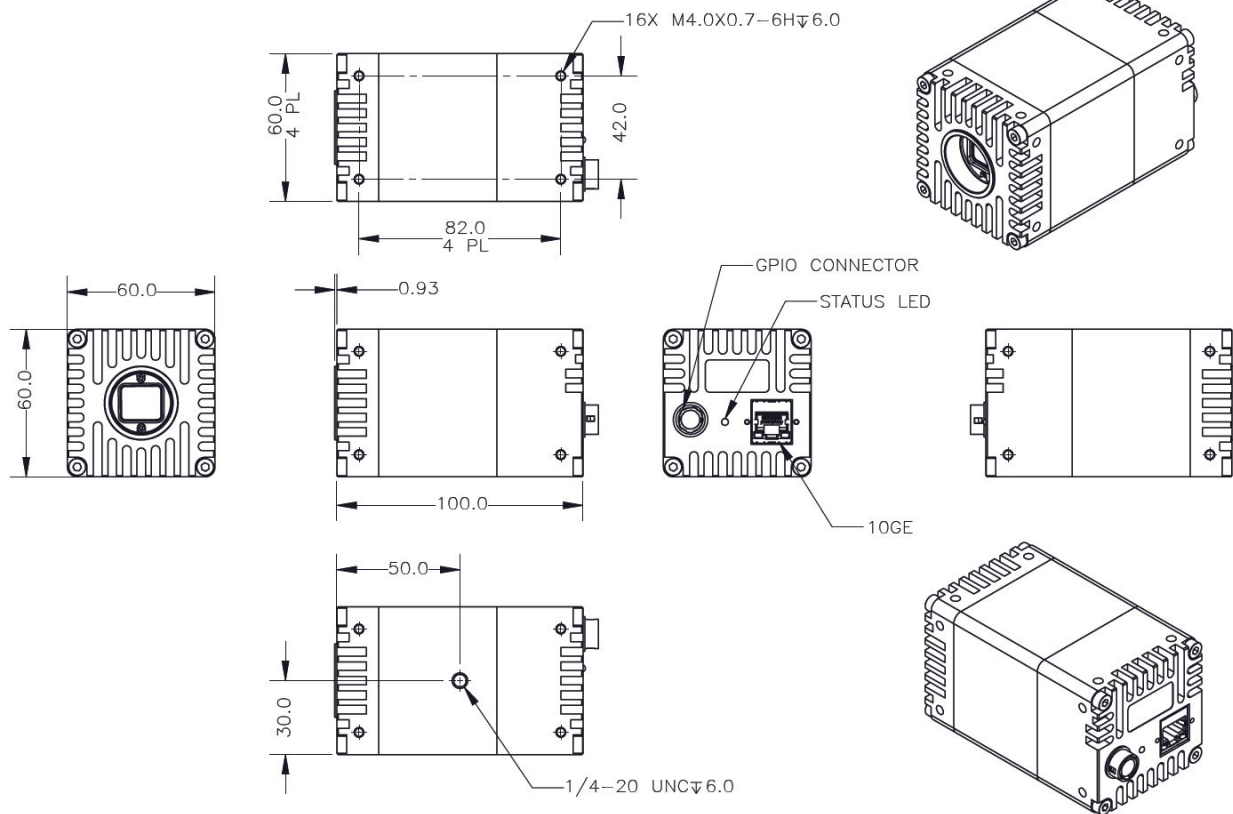

Oryx Dimensional Drawing—Standard Format

Standard Case Models

ORX-10G-51S5
ORX-10G-71S7
ORX-10G-89S6
ORX-10G-123S6

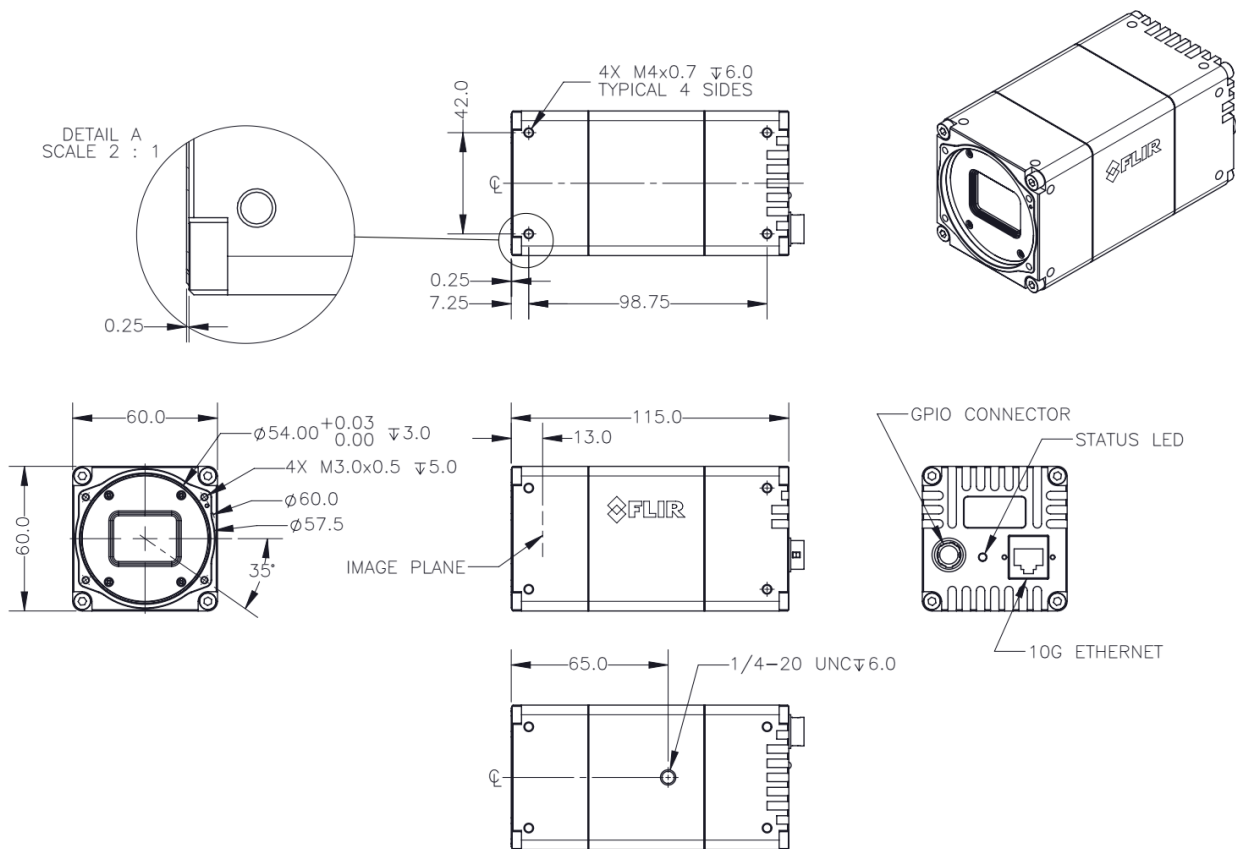

Oryx Dimensional Drawing—Large Format

Large Case Models

ORX-10G-245S8

ORX-10G-310S9

6.3 Interface Connector

The 8-pin RJ-45 Ethernet jack is equipped with two (2) M2 screwholes for secure connection. Pin assignments conform to the Ethernet standard.

6.4 Interface Cables

To purchase a recommended cable from Teledyne FLIR, visit the [Products Accessories](#) page.

Category 5e cables up to 40 meters in length can be used with 10GigE. For cable lengths greater than 40 meters, Category 6a cables should be used. Teledyne FLIR sells Category 5e cables.

Note: For optimal ESD protection, we recommend using a shielded Ethernet cable or connecting the camera housing to chassis ground (earth).

6.5 Interface Card

The camera must connect to an interface card. This is sometimes called a host adapter, a bus controller, or a network interface card (NIC).

A 10G BASE-T NIC is recommended for streaming images on the Ethernet network between the camera and host system.

See [How to Optimize GigE Network Adapter Settings](#) for more information on configuring for best performance.

To purchase a compatible card (PN: ACC-01-1101) from Teledyne FLIR, visit the [Products Accessories](#) page.

Note: For optimal video streaming and camera control performance, we recommend an Intel Pro chipset on a PCIe interface.

6.6 General Purpose Input/Output (GPIO)

The camera has an 12-pin GPIO connector on the back of the case. The connector is a Hirose HR10 (Mfg P/N: HR10A-10R-12SB). The mating connector is a Hirose HR10A (Mfg P/N: HR10A-10P-12P).

The custom model has an 8-pin GPIO connector on the back of the case.

See [Input/Output Control](#) for details on pin assignments and electrical characteristics.

6.7 Mounting Your Oryx

Using the Case

The case is equipped with the following mounting holes:

- Four (4) M4.0 x 0.7 mounting holes on each side of the case
- One (1) 1/4-20 UNC mounting hole on the bottom of the case (standard and large case only)

Note: The 97-02800-00100 model is intended to be mounted to a fixed customer-designed bracket inside a camera array no more than 2 meters high. Using the model outside of this design is not recommended.

Using the ACC-01-0018 Mounting Bracket (small case only)

The tripod mounting bracket is equipped with four (4) M2 mounting holes.

6.8 Camera Temperature and Heat Dissipation

You must provide sufficient heat dissipation to control the internal operating temperature of the camera.

The camera is equipped with an on-board temperature sensor. It allows you to obtain the temperature of the camera board-level components. The sensor measures the ambient temperature within the case.

As a result of packing the camera electronics into a small space, the camera can become hot when running. This is expected behavior and will not damage the camera electronics.



Warning! To avoid possible burns do not touch the camera while in operation. Wait at least 15 minutes after powering off before touching.

To reduce heat, use a cooling fan to set up a positive air flow around the camera, taking into consideration the following precautions:

- Mount the camera on a heat sink, such as a camera mounting bracket, made out of a heat-conductive material like aluminum.
- Make sure the flow of heat from the camera to the bracket is not blocked by a non-conductive material like plastic.
- Make sure the camera has enough open space around it to facilitate the free flow of air.

To access temperature information query the GenICam Device Control feature DeviceTemperature.

6.9 Lens Mounting

Lenses are not included with cameras. Teledyne FLIR sells a number of lenses compatible with our cameras from [our website](#). There is also a [Lens Calculator](#) to help choose an appropriate lens.

Related Knowledge Base Articles

[Selecting a lens for your camera](#)

6.9.1 Back Flange Distance

The Back Flange Distance (BFD) is offset due to the presence of both a 1 mm infrared cutoff (IRC) filter (color models only) and a 0.5 mm sensor package window. These two pieces of glass fit between the lens and the sensor image plane. The IRC filter is installed on color cameras. The sensor package window is installed by the sensor manufacturer. Both components cause refraction, which requires some offset in flange back distance to correct.

For more information about the IRC filter, see [Infrared Cut-Off Filters](#).

6.10 Non-Volatile Flash Memory

The Oryx has 4 MB of non-volatile flash memory for users to store data.

Related Knowledge Base Articles

[Storing data in on-camera flash memory](#)

6.11 Dust Protection

The camera housing is designed to prevent dust from falling directly onto the sensor's protective glass surface. In color models, this is achieved by placing an IR cut-off filter that sits above the surface of the sensor's glass. A removable plastic retainer keeps this glass/filter system in place. By increasing the distance between the imaging surface and the location of the potential dust particles, the likelihood of interference from the dust (assuming non-collimated light) and the possibility of damage to the sensor during cleaning is reduced.

Warning! Cameras are sealed when they are shipped. To avoid contamination, seals should not be broken until cameras are ready for assembly on site.

Warning! Use caution when removing the filter. Damage to any component of the optical path voids the Hardware Warranty. Removing the protective glass or filter alters the optical path of the camera, and may result in problems obtaining proper focus with your lens.

Related Knowledge Base Articles

[Removing the IR filter from a color camera](#)

[Selecting a lens for your camera](#)

6.12 Infrared Cut-Off Filters

Color camera cased models are equipped with an additional infrared (IR) cut-off filter. This filter can reduce sensitivity in the near infrared spectrum and help prevent smearing. The properties of this filter are illustrated in the results below.

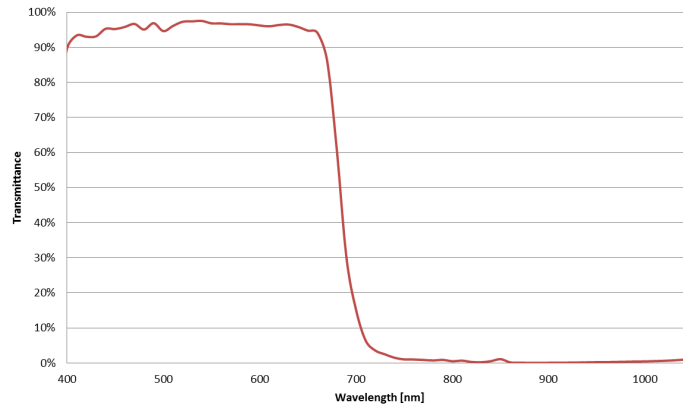

IR filter transmittance graph

Transmission	Wavelength
T=50%	680 nm ±10 nm
T>80%	400 nm - 420 nm
T>85%	420 nm - 650 nm
T average 1%	750 nm - 1100 nm
T<3%	750 nm - 1100 nm

The following are the properties of the IR filter glass:

	Small and Standard Size Models	Large Models (ORX-10G-245S8 / ORX-10G-310S9)
Type	Anti-reflective	
Material	Schott B270	
Dimensions	15.5 ±0.08 x 18 ±0.08 mm	31.5 ±0.08 x 24.5 ±0.08 mm
Thickness	1 ±0.07 mm	

For more information, see [Dust Protection](#).

6.13 Readout Method

6.13.1 Global Shutter

For cameras with a global shutter sensor, for each frame all of the lines start and stop exposure at the same time. The exposure time for each line is the same. Following exposure, data readout begins. The readout time for each line is the same but the start and end times are staggered. Readout time for a line is equal to $1/\text{Horizontal Line Frequency}$.

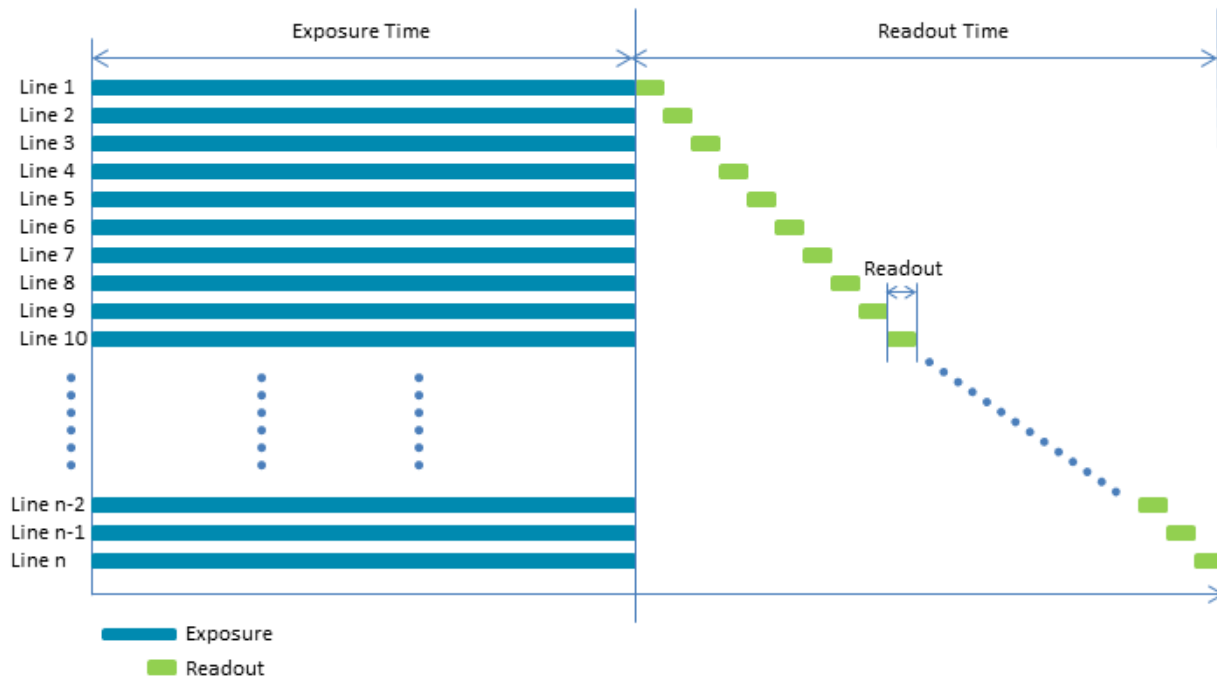

Some advantages of global shutter are more uniform brightness and minimal motion blur.

An advantage of a rolling shutter with global reset is a reduction in image artifacts typical of rolling shutters such as skew and wobble. However, because exposure lengthens throughout the frame, there may be a gradual increase in brightness from top to bottom of an image. This gradient can be diminished or even eliminated by using a strobe flash.

If the camera supports a rolling shutter with a global reset, the strobe can be set to active from the start of exposure of the first line to the end of exposure on the last line (Any pixel) or from the start of exposure on the last line to the end of exposure on the first line (All pixels).

7 Input/Output Control

7.1 General Purpose Input/Output (GPIO)

The camera has an 12-pin GPIO connector on the back of the case. The connector is a Hirose HR10 (Mfg P/N: HR10A-10R-12SB). The mating connector is a Hirose HR10A (Mfg P/N: HR10A-10P-12P).

The custom model has an 8-pin GPIO connector on the back of the case.

Small, Standard, and Large Case Models

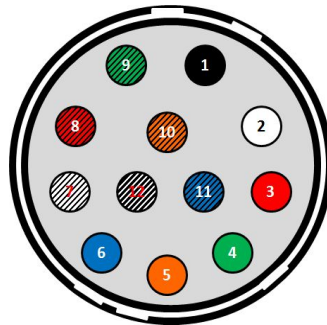

Color	Pin	Line	Function	Description
Black	1	N/A	GND	DC camera power ground
White	2	N/A	POWER	DC camera power
Red	3	Line 1	GPIO_OPT_OUT1	Opto-isolated output (GPO1)
Green	4	Line 4	GPIO_OPT_OUT2	Opto-isolated output (GPO2)
Orange	5	Line 0	GPIO_OPT_IN1	Opto-isolated input (GPI1)
Blue	6	Line 3	GPIO_OPT_IN2	Opto-isolated input (GPI2)
White with black stripes	7	Line 2	GPIO_TTL_IO3	TTL input/output 3*
Red with black stripes	8	Line 5	GPIO_TTL_IO4	TTL input/output 4*
Green with black stripes	9	N/A	GND	DC camera power ground
Orange with black stripes	10	N/A	POWER	DC camera power
Blue with black stripes	11	Line 6	3.3 V OUTPUT	+3.3 V output, current 120 mA (nominal) - firmware enabled
Black with white stripes	12	N/A	OPTO_GND	Ground for opto-isolated I/O, not connected to camera ground

*When configured as output line format is open drain, not TTL. Users should attach their own external pull-up resistor.

7.2 GPIO Electrical Characteristics

Both the opto-isolated input and output have over current protection.

The output is open collector and thus requires a pull-up resistor to operate. The rise time and bias current will be determined by the resistor value chosen. If the camera is generating an output signal that approaches the rise time plus the fall time of the opto-isolated circuit, care must be taken to optimize the pull-up resistor chosen to minimize the rise time while still remaining within the current limits of the output circuit.

The opto-isolated specifications listed below are applicable when power to the camera is provided through the interface and not through the GPIO.

Warning! To avoid damage, connect the OPTO_GND pin first before applying voltage to the GPIO line.

Warning! Prolonged use of the camera outside of the Operating Range described below may lead to unexpected behavior and should be avoided.

Operating Range

Description	Minimum	Maximum
Non-opto-isolated Voltage	0 V	24 V
Opto-isolated Input Voltage	0 V	30 V
Opto-isolated Output Voltage	0 V	24 V
Non-opto-isolated Sinking Current		25 mA
Opto-isolated Output Current		25 mA
3.3 V Output Current		200 mA

Absolute Maximum Ratings

Description	Minimum	Maximum
Non-opto-isolated Voltage	-24 V	42 V
Opto-isolated Input Voltage	-70 V	40 V
Opto-isolated Output Voltage	-24 V	24 V

Opto-isolated External Voltage Resistor Combinations

External Voltage	External Resistor	OPTO_OUT Low Voltage		OPTO_OUT High Voltage		Output Current	Output Current Low	Output Current High
		No Load	Load	No Load	Load	No Load	Load	Load
3.3 V	200 Ω	1.47 V	1.44 V	3.25 V	2.64 V	8.4 mA	2.52 mA	8.52 mA
5 V	1.0 kΩ	0.92 V	0.86 V	5 V	2.29 V	3.9 mA	2.68 mA	4.04 mA
12 V	2.4 kΩ	1.08 V	1.02 V	12.08 V	3.78 V	4.54 mA	3.44 mA	4.56 mA
24 V	4.7 kΩ	1.3 V	1.08 V	24 V	6.36 V	4.78 mA	3.7 mA	4.82 mA
30 V	4.7 kΩ	1.4 V	1.32 V	30 V	11.08 V	5.96 mA	3.02 mA	5.08 mA

Values are for reference only

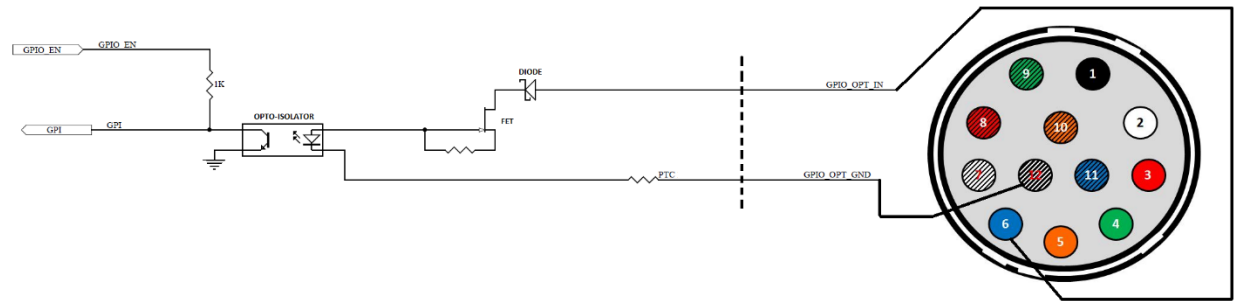
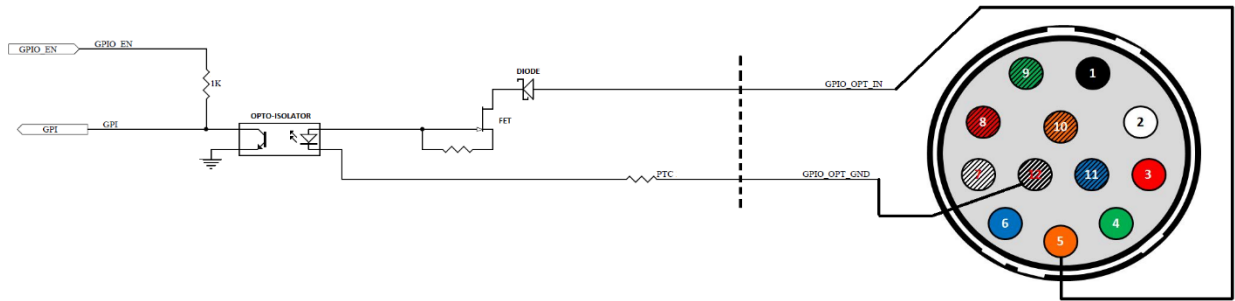

Opto-isolated input circuit

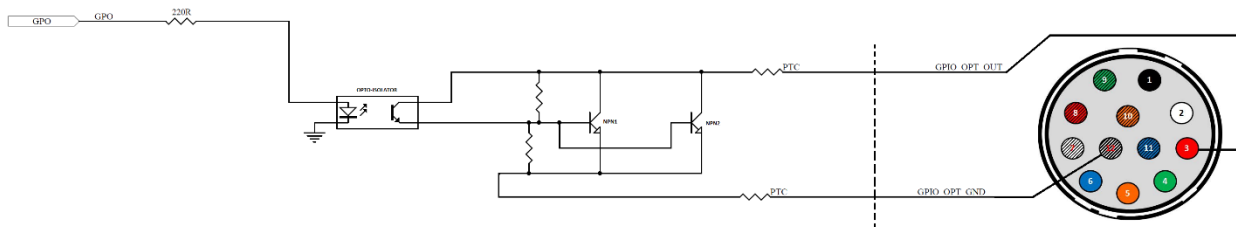

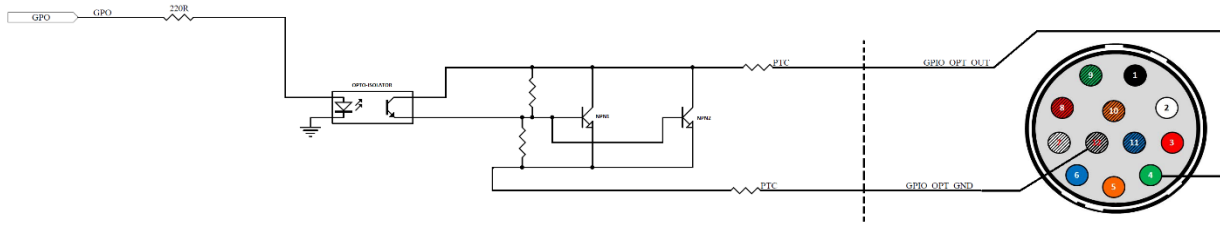

Opto-isolated output circuit

External Voltage Resistor Combinations at 90 FPS (Non-isolated input/output)

External Voltage	External Resistor	Output Current
3.3 V	1.0 Ω	3.1 mA
5.0 V	1.0 k Ω	4.8 mA
12 V	2.0 k Ω	6.0 mA
12 V	2.4 k Ω	5.0 mA
24 V	4.7 k Ω	5.2 mA

Values are for reference only

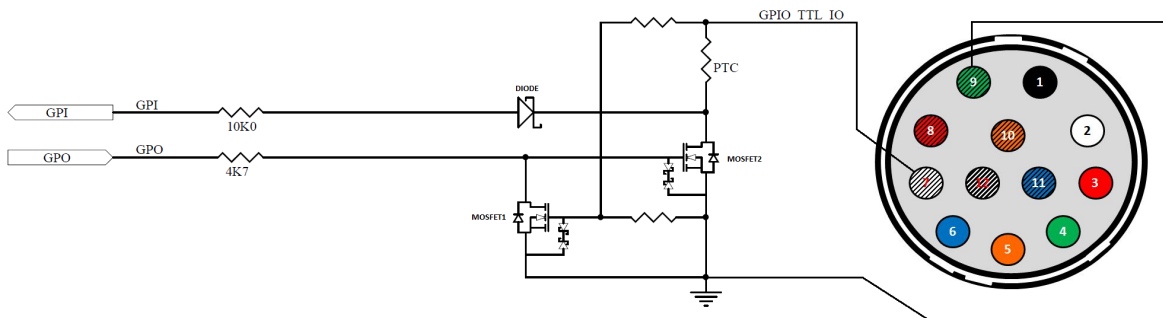
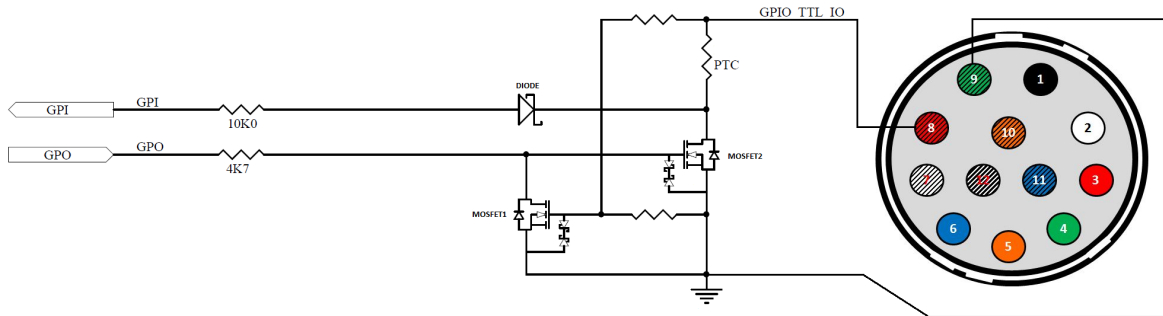

Input/Output circuit

7.3 Input Timing Characteristics

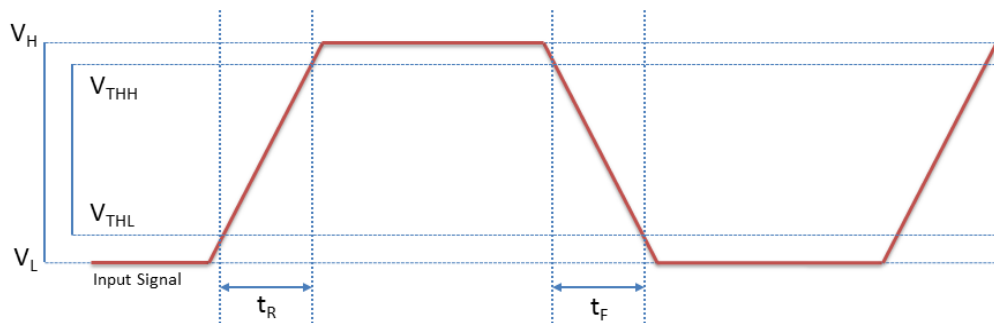

Input Timing Characteristics

Non-isolated Input Performance (measured at $V_{CC} = 5\text{ V}$, $R_{ext} = 1\text{ k}\Omega$)

Parameter	Symbol	Non-isolated
Input Low Voltage	V_L	0.85 V
Input High Voltage	V_H	4.94 V
Input Threshold High Voltage	V_{THH}	4.54 V
Input Threshold Low Voltage	V_{THL}	1.26 V
Cycle Rise Time	t_R	10.8 μs
Cycle Fall Time	t_F	2 μs
Current		4.1 mA

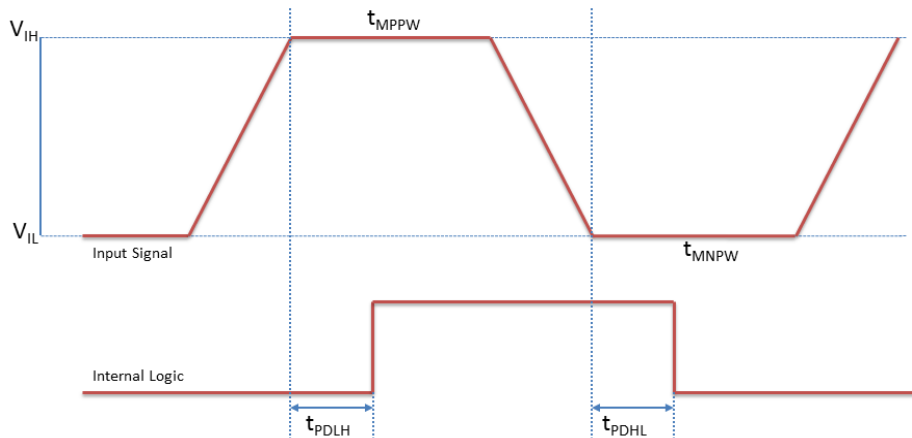
Opto-isolated Input Performance (V_{CC} = varying pk-pk)

Parameter	Symbol	Opto-isolated 5 V, 1 k Ω	Opto-isolated 3 V, 200 Ω
Input Low Voltage	V_{IL}	≤ 1.96 V	≤ 2 V
Input High Voltage	V_{IH}	≥ 2 V	≥ 2.05 V
Propagation Delay Low to High	t_{PDLH}	20.9 μ s	19.7 μ s
Propagation Delay High to Low	t_{PDHL}	5.6 μ s	16.7 μ s
Typical Positive Pulse Width	t_{MPPW}	12 μ s	12 μ s
Typical Negative Pulse Width	t_{MNPW}	6 μ s	6 μ s

7.4 Output Timing Characteristics

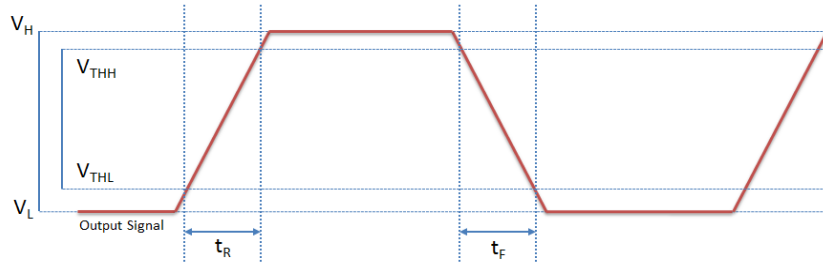

Output Timing Characteristics

Non-isolated Output Performance (measured at $V_{CC} = 5\text{ V}$, $R_{ext} = 1\text{ k}\Omega$)

Parameter	Symbol	Non-isolated
Output Low Voltage	V_L	0.23 V
Output High Voltage	V_H	4.95 V
Output Threshold High Voltage	V_{THH}	4.48 V
Output Threshold Low Voltage	V_{THL}	0.7 V
Cycle Rise Time	t_R	2.6 μs
Cycle Fall Time	t_F	0.23 μs
Opto Current		4.8 mA

Opto-isolated Output Performance (measured at $V_{CC} = 3.3\text{ V}$, $R_{ext} = 200\ \Omega$)

Parameter	Symbol	Opto-isolated	
		Load	No Load
Output Low Voltage	V_L	1.44 V	1.47 V
Output High Voltage	V_H	2.64 V	3.25 V
Output Threshold High Voltage	V_{THH}	2.52 V	3.07 V
Output Threshold Low Voltage	V_{THL}	1.56 V	1.65 V
Cycle Rise Time	t_R	5.2 μs	24 μs
Cycle Fall Time	t_F	28 μs	4.6 μs
Opto Current		3.08 mA	8.4 mA
Opto Isolator Delay (High to Low)		5.3 μs	5.5 μs
Opto Isolator Delay (Low to High)		12.7 μs	15.2 μs

Opto-isolated Output Performance (measured at $V_{CC} = 5\text{ V}$, $R_{EXT} = 1\text{ k}\Omega$)

Parameter	Symbol	Opto-isolated	
		Load	No Load
Output Low Voltage	V_L	0.86 V	0.92 V
Output High Voltage	V_H	2.29 V	5 V
Output Threshold High Voltage	V_{THH}	2.15 V	4.59 V
Output Threshold Low Voltage	V_{THL}	1.00 V	1.33 V
Cycle Rise Time	t_R	12 μs	10.3 μs
Cycle Fall Time	t_F	19.6 μs	17.2 μs
Opto Current		2.68 mA	3.9 mA
Opto Isolator Delay (High to Low)		3.9 μs	4.1 μs
Opto Isolator Delay (Low to High)		26.8 μs	25.1 μs

8 Troubleshooting

8.1 Support

Teledyne FLIR endeavors to provide the highest level of technical support possible to you. Most support resources can be accessed through your product's Support page.

[Oryx Support Articles](#)

[Oryx Resources](#)

The **Overview** tab contains links to:



Spinnaker SDK download



Application notes



Knowledge base articles



White papers



Warranty information

The **Resources** tab contains links to:

- EMVA Imaging Performance specification PDFs
- Camera References (HTML)
- Datasheets
- Drawings
- Firmware
- Getting Started manual PDFs
- Product Change Notifications (PCN)
- Technical Reference manual PDFs

The **Media** tab contains links to videos about sensor technology and camera use.

Contacting Technical Support

Before contacting Technical Support, have you:

1. Read the product documentation?
2. Searched the Product Support page?
3. Downloaded and installed the latest version of software and/or firmware?

If you have done all the above and still can't find an answer to your question, [contact our Technical Support team](#).

8.2 Status Indicator LED

LED	10GigE
No Light	No power or LED is in inactive state or LED is in error status state with no error
Blinking Green (1 blink)	Link-Local Address (LLA)
Blinking Green (2 blinks)	DHCP IP Address
Blinking Green (3 blinks)	Persistent IP Address
Solid Green	Acquisition Started
Rapid Flashing Green	Firmware update in progress
Flashing Green and Red	General Error

8.3 Network Status LEDs

No Light	No network connection
Left and Right Bright Green	10 GigE connection
Left Dim and Right Bright Green	1 GigE connection
Left and/or Right Blinking Green	Data transfer in progress

Contacting Us

For any questions, concerns or comments please contact us via the following methods:

Email	General questions
Support Ticket	Technical support
Website	Find specifications, support articles, downloads on the product page at Teledyne FLIR machine vision

Revision History

Version	Date	Description
1.0	October 27, 2017	Support for ORX-10G-51S5, ORX-10G-89S6, and ORX-10G-123S6
2.0	August 9, 2019	Support for ORX-10G-310S9 and ORX-10G-71S7
3.0	August 20, 2019	Support for ORX-10G-32S4
4.0	February 21, 2020	Support for ORX-10GS-32S4, ORX-10GS-51S5, ORX-10GS-89S6, and ORX-10GS-123S6 Updated recommended system configuration
4.1	April 9, 2020	Updated link to contact support Updated GPIO electrical and input / output timing
5.0	October 29, 2020	Support for ORX-10G-245S8
5.1	September 9, 2021	Support for custom model 97-02800-00100 Usage statement added to legal page. Additional warning for hot surface in Temperature section.
5.2	November 29, 2022	Updated links to camera website resources Branding to Teledyne FLIR