

REVISIONS			
REV.	DESCRIPTION	DATE	DCN NO
-	FOR QUOTING PURPOSES ONLY		

CABLE ENTRY SIDE

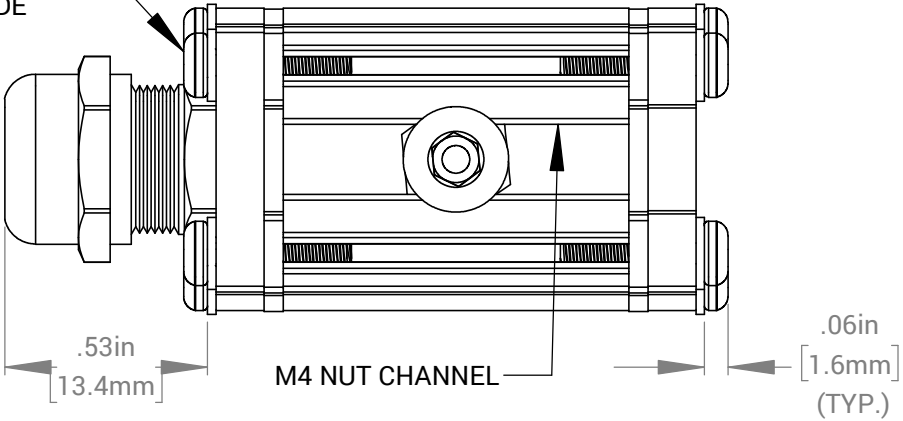

M4 MOUNTING SCREW

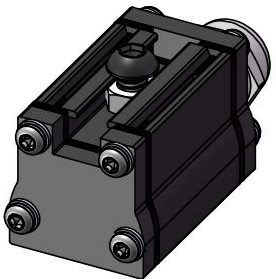
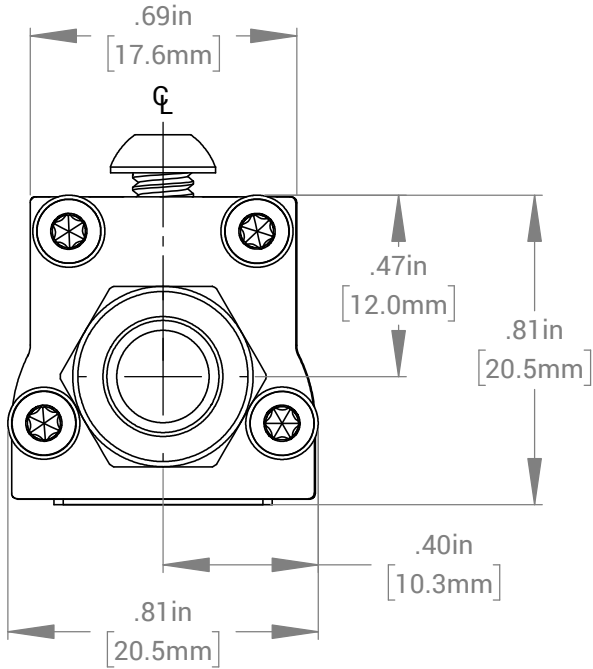
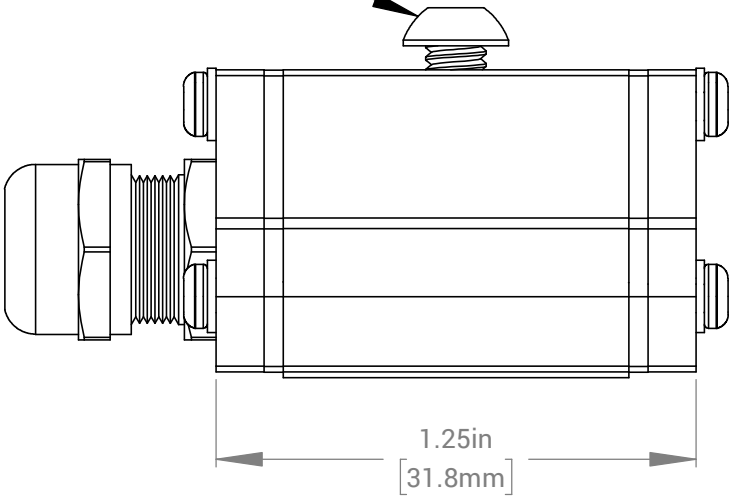

FOR REFERENCE ONLY

PROPRIETARY AND CONFIDENTIAL
 THESE DRAWINGS AND SPECIFICATIONS ARE THE EXCLUSIVE PROPERTIES OF ADVANCED ILLUMINATION INCORPORATED ISSUED IN STRICT CONFIDENCE AND SHALL NOT, WITHOUT THE PRIOR WRITTEN PERMISSION OF ADVANCED ILLUMINATION INC BE REPRODUCED, COPIED OR USED FOR ANY PURPOSE WHATSOEVER EXCEPT THE MANUFACTURE OF ARTICLES FOR ADVANCED ILLUMINATION INC

UNIT WEIGHT: .053 lbs

CUT USING: -		UNLESS OTHERWISE SPECIFIED:		DATE	NAME	 ADVANCED ILLUMINATION 440 STATE GARAGE ROAD, ROCHESTER, VERMONT 05767
		SURFACE SHOULD BE FREE OF SCRATCHES, BURRS, AND DENTS		11-JUN-18	T.MILLS	
		DIMENSIONS ARE IN: INCHES		CHECKED	--	TITLE: DRAWING, INSTALLATION, SL243 (SEALED)
		<u>TOLERANCES</u>		APPROVED	--	
		FRACTIONAL ± 1/16		MATERIAL		SIZE DWG. NO. REV A SL243 (SEALED) -
		ANGULAR: MACH ± 1 BEND ± 1		FINISH		
		TWO PLACE DECIMAL ± .010				SCALE: NTS/C CODE: - SHEET 1 OF 1
		THREE PLACE DECIMAL ± .005				
NEXT ASSY	USED ON	MAKE FROM				
APPLICATION						