

DATA SHEET

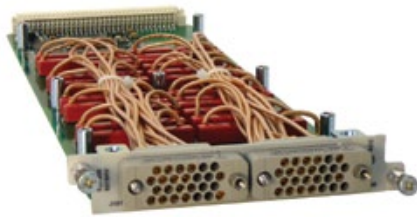

EX1200-6216HV

DUAL (1 X 16) 250 MHz, 500 V MULTIPLEXER

FEATURES

Greater than 250 MHz bandwidth

Very high-density (two 1x16 muxes)

500 V switching capability

Ideal for differential coaxial switching

Star configurations allow any channel to be connected to any other channel



www.vtiinstruments.com

RELIABLE DATA FIRST TIME EVERY TIME

OVERVIEW

The EX1200-6216HV is an RF switch module designed in a star configuration. A star switch allows any channel to be connected to any other channel. This configuration approach also allows for the creation of simple matrices (i.e. 8 x 1 x 8).

Additionally, for applications that require the switching of high voltage probes or transient power supply signals, the EX1200-6216HV provides the capability of switching up to 500 V and up to 250 MHz. This module can only be used in an EX1208 or EX1268A mainframe.

The EX1200-6216HV is part of the EX1200 family and can be mixed and matched with other modules in the family to configure high-density switching systems. The EX1200-6216HV can be controlled programmatically using IVI-Switch compliant calls. Both path level programming and individual relay control are available. Refer to the host driver documentation for additional details. This information can be used for individual relay control through the driver. Both single-wire and two-wire programming modes are available.

BLOCK DIAGRAM

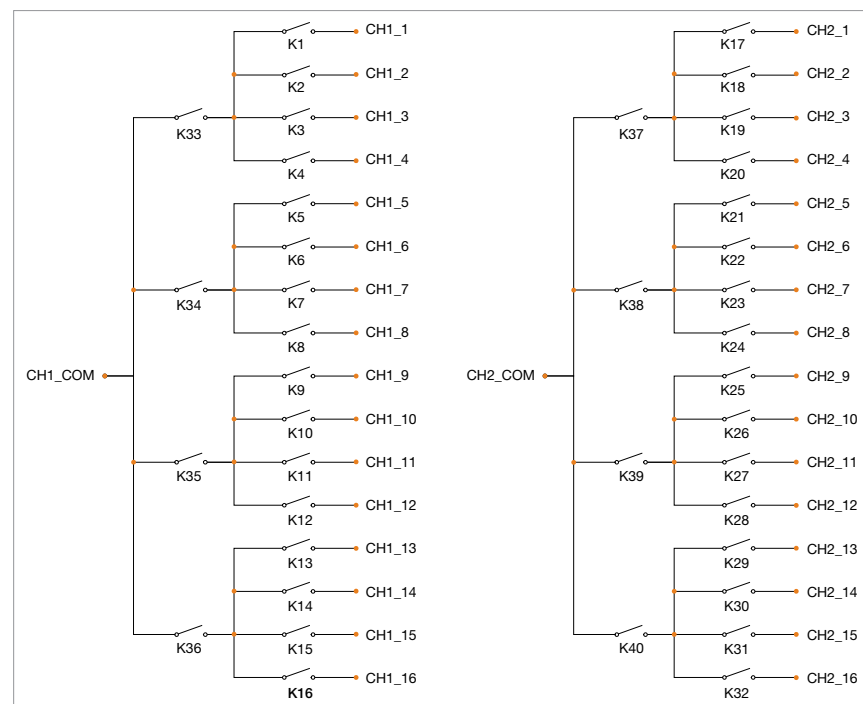

General Specifications

CHANNEL COUNT	Two (1 x 16) multiplexer channels
RELAY TYPE	Mercury-wetted reed ¹
MAXIMUM SWITCHING VOLTAGE	500 V AC
MAXIMUM SWITCHING CURRENT	0.5 A
MAXIMUM CARRYING CURRENT	2.0 A
MAXIMUM SWITCHING POWER	10 W
RATED SWITCH OPERATIONS	
@ 1 V, 10 mA	100 x 10 ⁶
SWITCHING TIME	< 1 ms
PATH RESISTANCE	< 500 mΩ (valid at 50 mV, 10 mA load)
BANDWIDTH (-3 dB)	250 MHz (typical)
INSERTION LOSS (TYPICAL)	
100 MHz	< 1.0 dB
250 MHz	< 3.0 dB
CROSSTALK (TYPICAL)	
100 MHz	< -45 dB
250 MHz	< -35 dB
ISOLATION (TYPICAL)	
100 MHz	< -45 dB
250 MHz	< -35 dB
VSWR (TYPICAL)	
100 MHz	< 1.2:1
250 MHz	< 1.5:1
CONNECTOR TYPE	Dual 26-pin

Note:

1. This module is for use in the 3U versions of the EX1200 series only (EX12x8, EX12x9). THIS MODULE CONTAINS POSITION-SENSITIVE, MERCURY SWITCHES. This module must be installed in an upright position and this position must be maintained in order for these switches to function properly. An arrow on the PCB illustrates proper orientation of the board.

Ordering Information

EX1200-6216HV	Dual (1 x 16) 250 MHz, 500 V multiplexer
ACCESSORIES AND TOOLS	
70-0150-000	26-pin mating connector and housing (2 required)
70-0149-000	10-pin/ferrule kit (RG 316 50 Ω)
70-0149-001	10-pin/ferrule kit (RG 178 50 Ω)
46-0018-000	Crimp tool, coax RG316 (50 Ω)
46-0018-001	Crimp tool, coax RG178 (50 Ω)
46-0021-000	Tool, pin extractor, size 16 contact, AMP M series