

DATA SHEET

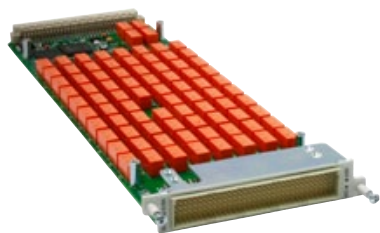

EX1200-3164

16 (1X4) 2-WIRE 300 V/2 A MULTIPLEXER

FEATURES

High-density 300 V/2 A multiplexing scanning (up to 384 two-wire channels in 1U footprint)

Maximum reconfigurability - 16 (1x4) blocks individually combinable under program control

Configure as 2- or 4-wire multiplexers under program control

Supports thermocouple, RTD, and thermistor measurements

Optional screw-terminal junction box includes built-in cold-junction compensation

Direct routing to DMM through internal analog measurement bus simplifies field wiring

Stub-breaking relays isolate the module from interfering with measurements being made on other modules



www.vtiinstruments.com

RELIABLE DATA FIRST TIME EVERY TIME

OVERVIEW

The EX1200-3164 high-density multiplexer module is designed to provide a flexible switching multiplexing architecture with 16 individual 1 x 4 2-wire multiplexers. Up to 96 1 x 4 two-wire channels can be accommodated in a single EX1200 full rack mainframe for maximum density or mixed and matched with other EX1200 plug-ins for flexibility. Applications include cable harness testing, semiconductor and PCB testing, and those in which multiple points need to be switched to a common resource. All relays also have individual control, and each path allows for hot switching of up to 300 V and 2 A (60 W DC max).

Each bank can be interconnected within a module under program control (via bussing relays) to form larger 2-wire muxes, up to a maximum of 1 x 64. The EX1200 analog bus can be used to configure larger multiplexers across modules as required to eliminate external wiring and helps reduce unterminated stubs effects. The analog bus can also be routed directly to the optional EX1200 series 6.5 digit DMM for direct measurements across the backplane further reduce external wiring. Stub-breaking relays remove the module from the analog bus to minimize a module's effect on measurements being made through other modules. An optional terminal block provides screw termination points for external field wiring. This terminal block also includes cold junction compensation reference for more precise temperature measurements.

BLOCK DIAGRAM

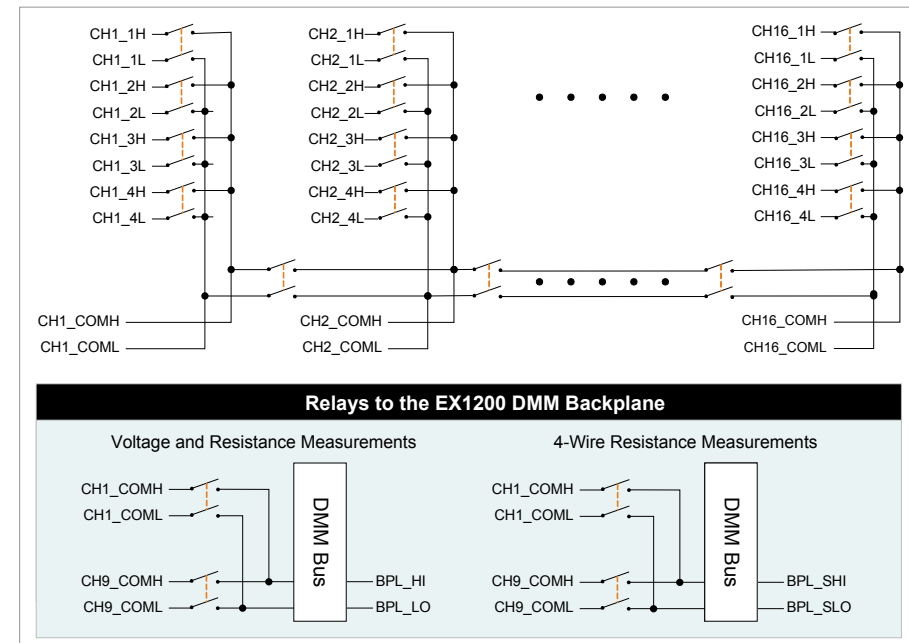

General Specifications

CHANNEL COUNT	Configured as either 16 (1x4), 8 (1x8), 4 (1x16), 2 (1x32) or 1 (1x64) 2-wire multiplexers
MAXIMUM SWITCHING VOLTAGE	300 V DC, 300 V AC rms
MAXIMUM SWITCHING CURRENT	2 A
MAXIMUM SWITCHING POWER ¹	60 W DC, 125 VA
RATED SWITCH OPERATIONS	
Mechanical	1 x 10 ⁸ (no load)
Electrical	1 x 10 ⁶ @ 50 V DC, 0.1 A (resistive) or 10 V DC, 10 mA (resistive)
MINIMUM CONTACT RATING ²	10 mV DC, 10 µA (resistive)
SWITCHING TIME	< 3 ms
PATH RESISTANCE	< 500 mΩ
INSULATION RESISTANCE	> 1 X 10 ⁹ Ω
MAXIMUM THERMAL OFFSET PER CHANNEL (HI-LO)	< 3 µV
CAPACITANCE	
Open channel	< 50 pF
Channel-mainframe	< 20 pF
High-low	< 50 pF
BANDWIDTH (-3 dB)	> 45 MHz
CROSSTALK (TYPICAL)	
1 MHz	< -70 dB
10 MHz	< -50 dB
ISOLATION (TYPICAL)	
1 MHz	< -65 dB
10 MHz	< -55 dB
CONNECTOR TYPE	160-pin

Notes:

1. Maximum switched power is derated non-linearly as voltage is increased.
2. This value is in reference to a resistive load. Minimum capacity changes depending on switching frequency and environmental conditions.

Ordering Information

EX1200-3164	16 (1x4) 2-wire 300 V/2 A multiplexer
ACCESSORIES AND TOOLS	
70-0363-504	Strain relief bracket (includes connector, recommended accessory)
70-0363-503	Strain relief bracket kit (without connector)
52-0109-000	Crimp pin (includes 100 crimp pins)
27-0088-160	Mating connector (one per board)
46-0010-000	Crimp tool (DIN)
46-0011-000	Extraction tool (DIN)
70-0363-505	160-pin, unterminated cable assembly, 3 ft
70-0367-008	EX1200-TB160-2 terminal block, differential module