

REVISIONS			
REV.	DESCRIPTION	DATE	DCN NO
-	FOR QUOTING PURPOSES ONLY		

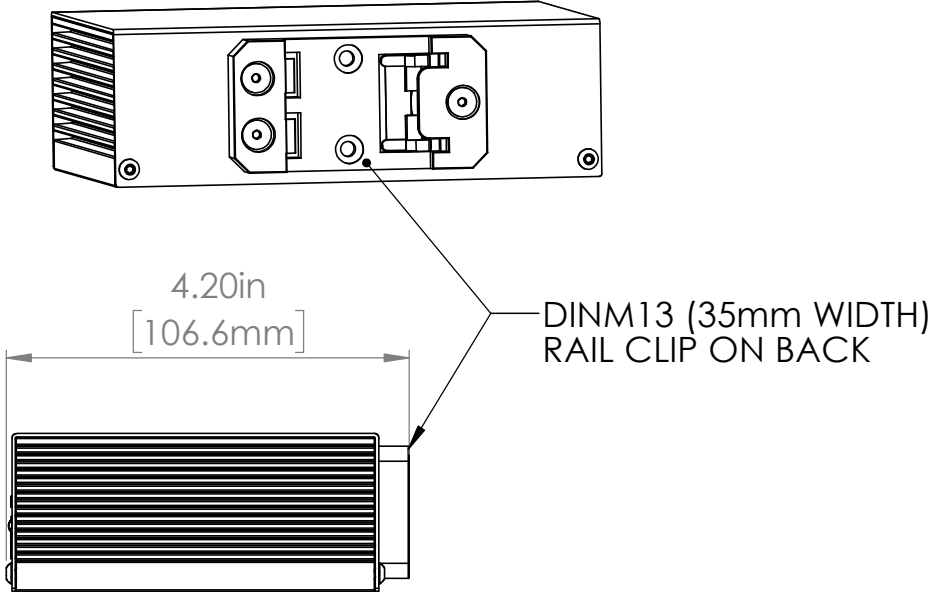
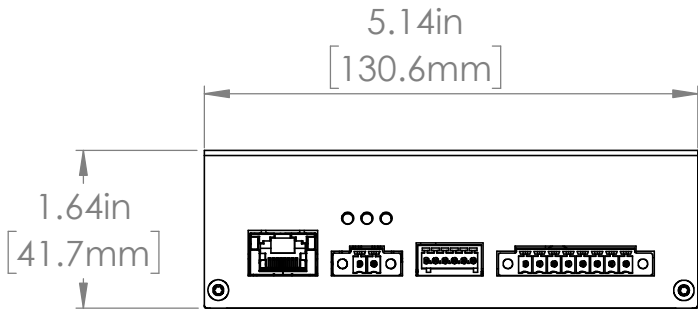

FOR REFERENCE ONLY

PROPRIETARY AND CONFIDENTIAL
 THESE DRAWINGS AND SPECIFICATIONS ARE THE EXCLUSIVE PROPERTIES OF ADVANCED ILLUMINATION INCORPORATED ISSUED IN STRICT CONFIDENCE AND SHALL NOT, WITHOUT THE PRIOR WRITTEN PERMISSION OF ADVANCED ILLUMINATION INC BE REPRODUCED, COPIED OR USED FOR ANY PURPOSE WHATSOEVER EXCEPT THE MANUFACTURE OF ARTICLES FOR ADVANCED ILLUMINATION INC

UNIT WEIGHT: 1.03 LBS

CUT USING: -		UNLESS OTHERWISE SPECIFIED: SURFACE SHOULD BE FREE OF SCRATCHES, BURRS, AND DENTS DIMENSIONS ARE IN: INCHES <u>TOLERANCES</u> FRACTIONAL $\pm 1/16$ ANGULAR: MACH ± 1 BEND ± 1 TWO PLACE DECIMAL $\pm .010$ THREE PLACE DECIMAL $\pm .005$ MAKE FROM -	DATE 02-AUG-19	NAME T.MILLS	ADVANCED ILLUMINATION 440 STATE GARAGE ROAD, ROCHESTER, VERMONT 05767
NEXT ASSY	USED ON	FINISH AS NOTED ON INDIVIDUAL DRWS	CHECKED --	APPROVED --	
APPLICATION		AS NOTED ON INDIVIDUAL DRWS	SIZE DWG. NO. REV A DCS-400E -		SCALE: NTS/C CODE: - SHEET 1 OF 1