

New Scale Technologies

M3-LS-3.4-15 Linear Smart Stage

High load, long travel micro positioning stage features built-in controller

- **All-in-one microstage - no separate controller**
 - Direct high-level command interface (I²C or SPI)
 - USB adapter enables direct connection to PC
- **Small:** < 32x32x11 mm *including controller*
- **Absolute encoding:** high repeatability, no homing
- **Low power:** 6 VDC, ~5 W (only when moving)
 - For integration into battery powered devices
- **Long stroke:** 15 mm
- **High force:** 1 N (~100g load vertical, ~200g horizontal)
- **High stiffness** with crossed roller bearing design

Absolute positioning, quiet operation

The M3-LS-3.4-15 is a direct-drive precision piezoelectric micro stage with embedded controller, designed for integration into compact instruments. With long travel and 100 gram vertical load capacity, it has 0.5 μ m resolution for precise, repeatable positioning of optics, probes, sensors and more.

Absolute encoding means there is no need to home the stage on power-up, eliminating errors and disruptions in processes and experiments. It has high stiffness with no gears or backlash.

With quiet operation and no high voltage, M3-LS Smart Stages are superior to piezo inertia (stick-slip) stages especially for near-patient instruments and wearable devices.

Embedded controller means "all-in-one" simplicity for smallest size, fastest integration

All drive electronics are integrated right into the stage housing to give product designers the smallest system size and fastest, easiest integration into miniature OEM systems.

The M3-LS-3.4-15 Smart Stage accepts simple high-level motion commands directly via standard serial interface (I²C or SPI) or via USB with adapter. Control multiple stages from one New Scale Pathway™ software screen. Or use the intuitive script generator to create command sequences for automated operation.

Precision motion in battery-powered systems

The M3-LS-3.4-15 Linear Smart Stage can be powered by standard batteries or any low-cost DC supply. The internal SQUIGGLE® motor holds position with no power. The embedded controller's sleep mode further reduces power consumption.

SMALL, PRECISE, SMART ... IN MOTION

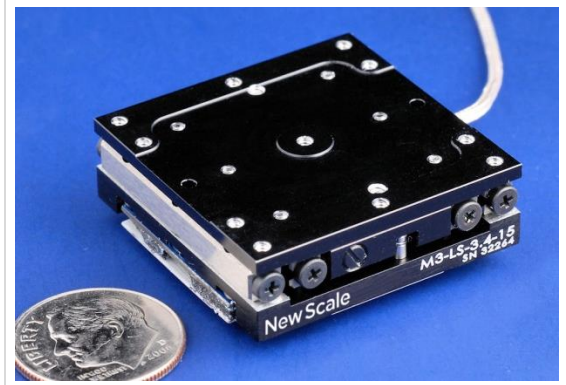

The M3-LS-3.4 Linear Smart Stage has a built-in controller for small system size and fast integration into miniature instruments.

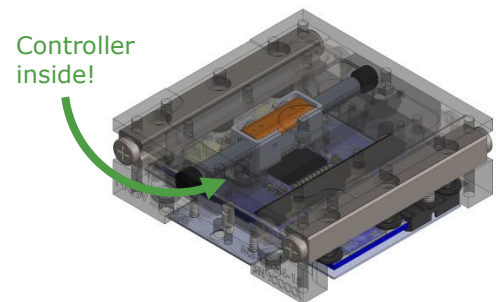

APPLICATIONS

- Hand-held and battery-powered instruments
- Biomedical devices
- Miniature/embedded microscopes
- Spectroscopy
- Precision opto-mechanical alignment
- Micro manipulation



Stages are easily assembled into XY and XYZ configuration for microscopy applications requiring small size and battery-powered operation.

M3-LS-3.4-15 Linear Smart Stage

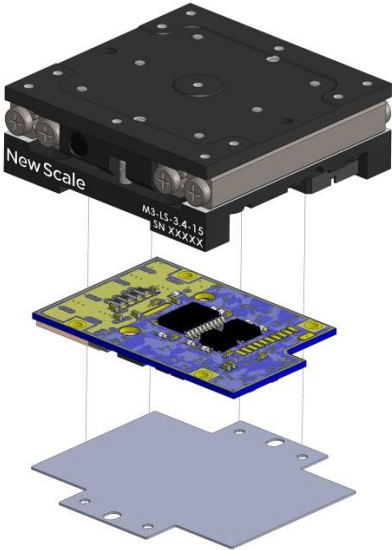

M3-LS Smart Stages have embedded controllers and accept high-level commands directly from a system processor via standard serial interface (I2C or SPI). A USB adapter is available for easy connection to a PC.

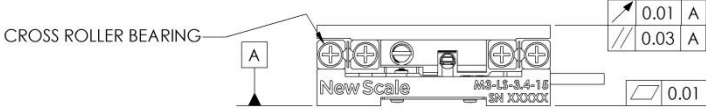
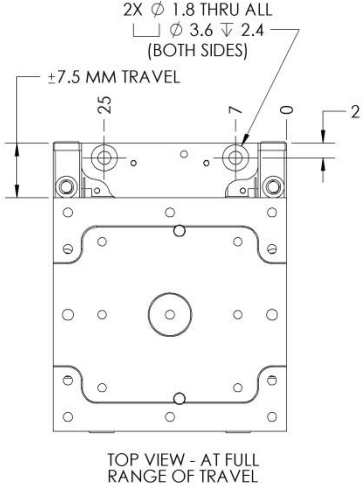
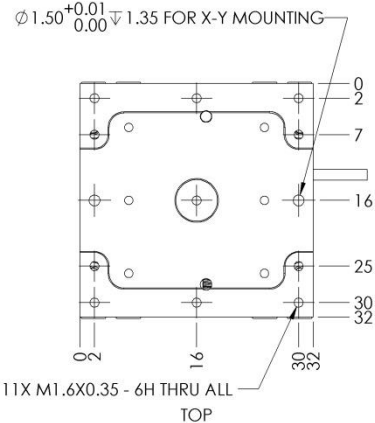
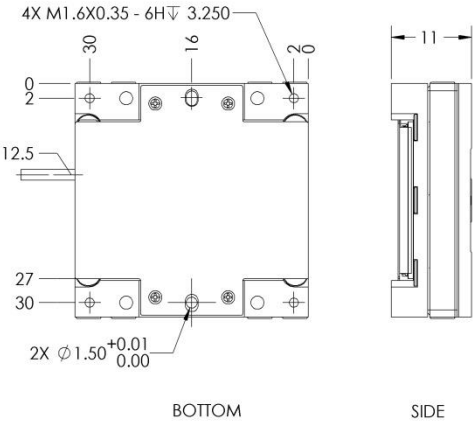

M3-LS-3.4-15 Linear Smart Stage 2-axis configuration (XY)

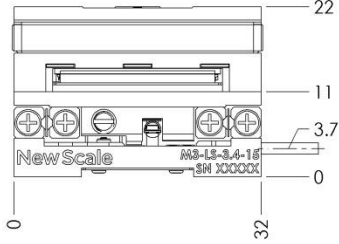
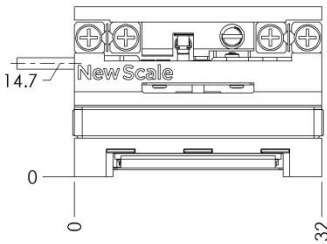

M3-LS-3.4-15 Linear Smart Stage 3-axis configuration (XYZ)

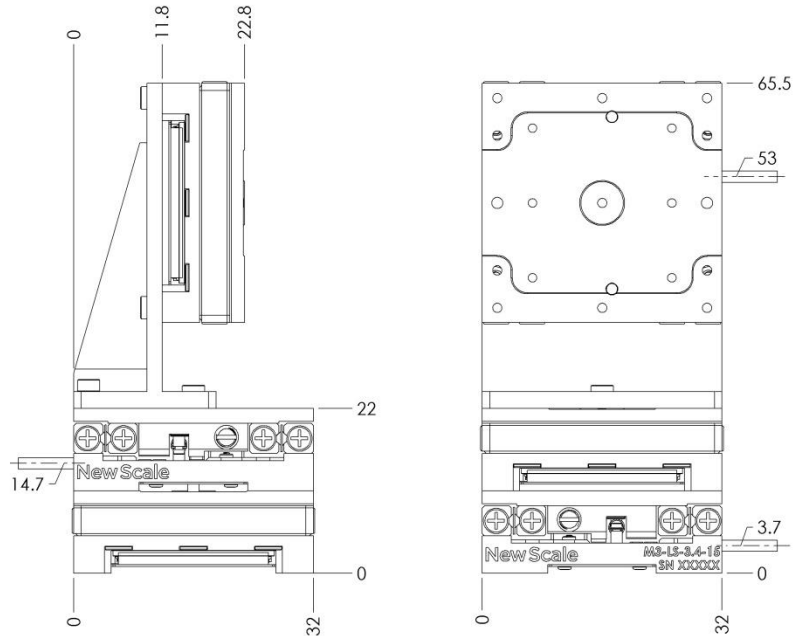
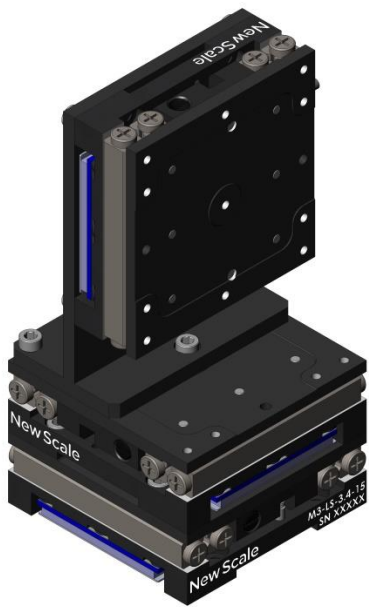

Specifications

MODEL	M3-LS-3.4-15
Travel Range (Stroke)	15 mm
Dimensions	32 x 32 x 11 mm
Mass (includes controller)	30 grams (Smart Stage) 36 grams (Smart Stage + cable + connector)
Moving mass (vertical) (note 1)	100 grams
Moving mass (horizontal) (note 1)	200 grams
Force (operating)	1 N
Speed (at operating force)	> 4 mm/s
Duty cycle	50% max recommended
Closed-loop performance	
Resolution	0.5 μm with absolute encoding
Bi-directional repeatability	< 5 μm
Accuracy	< 20 μm
Input Power (note 2)	6 V DC +/- 5% 5 W typical at 4mm/s, 1 N load, closed-loop < 0.2 W quiescent
Mechanical stage	
Static parallelism	< 30 μm
Runout	< 10 μm
Pitch and yaw	< 1 mrad
Absolute maximum load	10 N
Environment	
Relative humidity	< 70%
Operating temperature	+5 °C to +40 °C
Storage temperature	-40 °C to +85 °C
Compliance	CE / RoHS
Controller	Integrated into the smart stage
Control interface	Via USB adapter from PC or directly to I ² C or SPI serial interface

Note 1: Higher mass is possible but will affect performance and lifetime.
Note 2: Power depends on input voltage, speed and load.

New Scale Pathway™ software included in the developer's kit provides control of multiple stages from one screen, and an intuitive scripting tool for code development.

Ordering Information

Order Developer's Kits from distributors. Contact New Scale for information about configuring multi-axis systems and to discuss volume pricing.

MODEL	Description
DK-M3-LS-3.4-15	Developer's kit, 15 mm travel <ul style="list-style-type: none"> One M3-LS-3.4-15 linear smart stage with integrated controller USB adapter and breakout board Power supply New Scale Pathway software Accessories
M3-LS-3.4-15	Linear smart stage (15 mm travel) with integrated controller and cable