

# CM300xi-ULN Probe System

This guide defines the facility requirements for operation of your FormFactor CM300xi probe station. The information included here applies to Model CM300xi-ULN.

Facility requirements for thermal systems are listed separately. See the Facility Planning Guide specific to your thermal system for details.

For definitions of the icons in this document, please refer to the notational conventions described in your user guide.







## Probe Station Requirements

<b>Clean Dry Air (CDA)</b>	General use (CDA VIT)	<ul style="list-style-type: none"> <li>• ISO 8573.1 Class 1.4.1 (3°C pressure dew point, oil less than 0.01 mg/m<sup>3</sup>)</li> <li>• 8 mm OD push-in tube connection</li> <li>• 6-10 bar (87-145 psi)</li> <li>• Flow rate for semi-automated prober: max. 10 l/min (0.35 CFM)</li> <li>• Flow rate for fully-automated prober with MHU301: max. 40 l/min (1.41 CFM)</li> </ul>
	MicroChamber probing environment (purge)	<ul style="list-style-type: none"> <li>• ISO 8573.1 Class 1.x.1 (required pressure dew point is dependent on operating temperature, oil less than 0.01 mg/m<sup>3</sup>), 7-10 bar (102-145 psi)                             <ul style="list-style-type: none"> <li>– Required pressure dew point of PURGE air is dependent on operating temperature range:                                     <ul style="list-style-type: none"> <li>○ Thermal system operated down to +20°C: ≤ -20°C at SATP* -&gt; ISO8573.1 class 1.3.1</li> <li>○ Thermal system operated down to -40°C: ≤ -50°C at SATP* -&gt; ISO8573.1 class 1.1.1</li> <li>○ Thermal system operated down to -60°C: ≤ -70°C at SATP* -&gt; ISO8573.1 class 1.1.1</li> </ul> </li> </ul> </li> <li>• Semi- and fully-automated systems (one station):                             <ul style="list-style-type: none"> <li>– Max flow: 240 l/min (8.5 CFM) at SATP* supplied at 6.9 bar (100 psi) gage</li> <li>– Continuous flow: 80 l/min (2.8 CFM) at SATP* supplied at 5 bar (73 psi) gage</li> </ul> </li> </ul> <p><b>NOTE   HINWEIS   REMARQUE</b></p> <p><i>Lower available peak flow may extend cooling and conditioning times.</i></p> <p><i>Ein niedrigerer verfügbarer Spitzenfluss kann die Kühl- und Konditionierungszeiten verlängern.</i></p> <p><i>Un débit de pointe plus faible peut prolonger les temps de refroidissement et de conditionnement.</i></p> <ul style="list-style-type: none"> <li>• 12 mm OD push-in tube connection (3 m max tube length)</li> <li>• Chamber atmospheric pressure dew point:                             <ul style="list-style-type: none"> <li>– Thermal system operated down to +20°C: ≤ -20°C at SATP*</li> <li>– Thermal system operated down to -40°C: ≤ -50°C at SATP*</li> <li>– Thermal system operated down to -60°C: ≤ -70°C at SATP*</li> </ul> </li> </ul>

# CM300xi-ULN Probe System

CDA (cont'd)	MicroChamber probing environment (purge) (cont'd)	 <p><b>DANGER   ACHTUNG   DANGER</b></p> <p><i>FormFactor does not endorse or recommend using nitrogen instead of CDA for thermal system operation with any FormFactor system due to the risk of oxygen depletion in the working environment. If your testing configuration requires the use of nitrogen instead of CDA for MicroChamber purge, time in Quick Purge mode should be controlled. Discuss your setup with your safety and facilities departments to ensure that the oxygen flow in your working environment is adequate to dissipate any nitrogen build up. The use of oxygen sensor alarms is also recommended.</i></p> <p><i>FormFactor schreibt die Verwendung von Stickstoff anstelle von reiner Trockenluft nicht vor und spricht hierfür auch keine Empfehlung aus, was die verschiedenen FormFactor-Systeme anbetrifft. Es besteht nämlich das Risiko, dass am Einsatzort der Luftsauerstoff aufgebraucht wird. Wenn Sie sich für die Verwendung von Stickstoff entscheiden, da Ihre Testkonfiguration für die MicroChamber-Spülung die Verwendung von Stickstoff anstelle von reiner Trockenluft erfordert, ist eine Begrenzung der Zeit, in der das System im Schnellspülmodus (Quick Purge) verweilt, erforderlich, da fortlaufend Stickstoff aus dem System an die Umwelt abgegeben wird. Sprechen Sie Ihren Systemaufbau mit Ihren Beauftragten für Arbeitssicherheit und Anlagenmanagement durch um sicherzustellen, dass ausreichend Sauerstoff in der Raumluft Ihrer Arbeitsumgebung vorhanden ist und eine übermäßige Anreicherung der Raumluft mit Stickstoff verhindert werden kann. Darüber hinaus wird die Verwendung eines Alarmsystems mit Sauerstoffsensoren empfohlen.</i></p> <p><i>FormFactor n'approuve ni ne recommande l'utilisation d'azote au lieu d'air sec propre sur aucun de ses systèmes, en raison du risque d'appauvrissement en oxygène que cela peut entraîner en milieu de travail. Si vous décidez d'utiliser de l'azote car votre configuration de contrôle nécessite son emploi au lieu d'air sec propre pour purger le système MicroChamber, vous devez limiter le temps consacré en mode de purge rapide (Quick Purge), car l'azote sera constamment évacué du système vers l'environnement. Discutez de votre configuration avec les services responsables de la sécurité et des installations pour vous assurer que le débit d'oxygène dans l'environnement de travail est suffisamment adéquat pour éviter une accumulation excessive d'azote. L'utilisation d'un détecteur d'oxygène est également recommandée.</i></p>
Vacuum		<ul style="list-style-type: none"> <li>• Wafer hold on chuck and positioners:             <ul style="list-style-type: none"> <li>– Required: &lt; 250 mbar (7.4 inHg) absolute/ &lt; -760 mbar (-22.5 inHg) gauge at SATP*. Absolute vacuum pressure must not increase for leakage rates up to 10 l/min (0.35 CFM).</li> <li>– 10 mm OD push-in tube connection (3 m max. tube length)</li> </ul> </li> <li>• Wafer hold only (while under test to ensure measurement performance):             <ul style="list-style-type: none"> <li>– Vacuum pressure stability: ± 10 mbar (0.3 inHg)</li> </ul> </li> </ul>

# CM300xi-ULN Probe System

<p><b>Power</b></p>	<p>Power conditioning modules:</p> <ul style="list-style-type: none"> <li>• ULN-EMO-MU</li> <li>• ULN-FM-4</li> <li>• ULN-FM-6</li> <li>• ULN-FM-6i</li> </ul>	<p>CM300xi-ULN probe stations include a standard Power Conditioning Unit that includes 2 modules (ULN-EMO-MU, and ULN-FM-4) in a rack mount system. This will support a typical TestCell configuration, including a ULN probe station and one set of instruments for noise measurements.</p> <p>For TestCell configurations that use multi-channel noise instrumentation or include extra instruments, additional power conditioning modules (ULN-FM-6 &amp; ULN-FM-6i) should be ordered to support all equipment in the TestCell. See the CM300xi-ULN Configuration Guide for more information.</p> <p><b>WARNING   WARNUNG   AVERTISSEMENT</b></p> <p> You must provide a dedicated GFCI circuit breaker with 30 mA ground fault detection for each power conditioning module.</p> <p><i>Sie müssen für jedes Stromverteilungfiltermodul einen eigenen FI-Schutzschalter mit 30-mA-Erdschlusserkennung bereitstellen.</i></p> <p><i>Vous devez fournir un disjoncteur GFCI dédié avec détection de défaut à la terre de 30 mA pour chaque module de filtrage d'alimentation.</i></p> <ul style="list-style-type: none"> <li>• Customers must supply a power line rated at 200-240VAC,50/60Hz, 30A Inlet for each ULN power conditioning module</li> <li>• Short Circuit Current Rating (SCCR):10kA (UL508A)</li> <li>• Standard PCU configuration requires two power lines. Add one extra power line for each additional power conditioning module ordered.</li> </ul> <table border="1" data-bbox="589 940 1430 1438"> <thead> <tr> <th>Location</th> <th>Description</th> <th>Plug/Connector</th> </tr> </thead> <tbody> <tr> <td>North America</td> <td> <ul style="list-style-type: none"> <li>• 220V,30A</li> <li>• NEMA L6-30 (locking)</li> <li>• 3-pin</li> </ul> </td> <td> <p>Plug</p>  </td> </tr> <tr> <td>Outside North America</td> <td> <ul style="list-style-type: none"> <li>• IEC 60309</li> <li>• 250VAC, 30-32A</li> <li>• 3-pin</li> </ul> </td> <td> <p>Plug                      Receptacle</p>  </td> </tr> </tbody> </table>	Location	Description	Plug/Connector	North America	<ul style="list-style-type: none"> <li>• 220V,30A</li> <li>• NEMA L6-30 (locking)</li> <li>• 3-pin</li> </ul>	<p>Plug</p> 	Outside North America	<ul style="list-style-type: none"> <li>• IEC 60309</li> <li>• 250VAC, 30-32A</li> <li>• 3-pin</li> </ul>	<p>Plug                      Receptacle</p> 
Location	Description	Plug/Connector									
North America	<ul style="list-style-type: none"> <li>• 220V,30A</li> <li>• NEMA L6-30 (locking)</li> <li>• 3-pin</li> </ul>	<p>Plug</p> 									
Outside North America	<ul style="list-style-type: none"> <li>• IEC 60309</li> <li>• 250VAC, 30-32A</li> <li>• 3-pin</li> </ul>	<p>Plug                      Receptacle</p> 									
<p>Overvoltage</p>		<ul style="list-style-type: none"> <li>• Transient overvoltage: Category II (IEC 60364-4-443)</li> <li>• Main supply voltage fluctuations not to exceed <math>\pm 10\%</math> of the nominal voltage</li> </ul>									
<p>AC power line harmonics</p>		<ul style="list-style-type: none"> <li>• Fundamental power line frequency to 50<sup>th</sup> harmonic</li> <li>• Total harmonics &lt;3%</li> </ul>									
<p>For information on other optional components, refer to the data sheet for the particular item.</p>											

# CM300xi-ULN Probe System

<b>Environmental Conditions</b>	Operating	<ul style="list-style-type: none"> <li>• Altitude up to 2000 m</li> <li>• For indoor use in a dry location only</li> </ul>		
	Temperature	<ul style="list-style-type: none"> <li>• Operating range: +18°C to +24°C</li> <li>• Max. temperature variation: +/- 1 K</li> </ul>		
	Relative humidity	<ul style="list-style-type: none"> <li>• 20% to 60% (20% to 50% with sub-ambient thermal system)</li> </ul>		
	IP rating	<ul style="list-style-type: none"> <li>• X0</li> </ul>		
	Pollution degree	<ul style="list-style-type: none"> <li>• 2</li> </ul>		
	Ambient vibration	The probe station is intended for use in an environment having background vibrations at or below the ISO Operating Theatre level: <ul style="list-style-type: none"> <li>• Maximum level 4000 micro-in./sec (72 dB), measured using the 1/3-octave-band velocity spectra method</li> </ul>		
	Floor vibration	<ul style="list-style-type: none"> <li>• 1-100 Hz</li> <li>• <math>\leq 100 \mu\text{g}</math> (<math>g = 9.8 \text{ m/s}^2</math>)</li> </ul>		
	Magnetic field	<ul style="list-style-type: none"> <li>• 30 Hz to 10 kHz</li> <li>• <math>\leq 1</math> milliGauss</li> </ul>		
	Clean room class	<ul style="list-style-type: none"> <li>• Class ISO 7 corresponding to ISO 14644-1 (equivalent class 10,000 per US FED STD209E)</li> </ul>		
<b>Dimensions (WxDxH)</b>	Probe station(s)	See <a href="#">Station and MHU Dimensions</a> on page 7 for details on dual prober, fully- and semi-automated system configurations.		
	Accessories	Additional height due to optional accessories such as cameras and laser cutters can add up to the station maximum of 900 mm.		
	Joystick	<ul style="list-style-type: none"> <li>• 102 x 150 x 150 mm (4 x 6 x 6 in.), with connector installed</li> <li>• Located on the control console. Alternate placement may require an additional table.</li> </ul>		
	Clearance	Front	<ul style="list-style-type: none"> <li>• 800 mm (32 in.) for operator/installation during installation or service</li> </ul>	
		Back	<ul style="list-style-type: none"> <li>• 1000 mm (39 in.) for service access</li> <li>• 800 mm (32 in.) when using optional holders for monitor, keyboard or test instrument</li> </ul>	
		Left/right	<ul style="list-style-type: none"> <li>• 200 mm (8 in.) for cables, maximum 450 mm (18 in.) for use of control console</li> <li>• 800 mm (32 in.) during installation or service, or permanently when using optional holders for monitor, keyboard or test instrument</li> </ul>	
		Top	<ul style="list-style-type: none"> <li>• 400 mm (16 in.)</li> </ul>	
		Additional clearance may be required for thermal system cooling units.		
	ULN-EMO-MU	<ul style="list-style-type: none"> <li>• 425 x 642 x 155 mm (16.75 x 25.26 x 6.12 in.)</li> </ul>		
	ULN-FM-4	<ul style="list-style-type: none"> <li>• 426 x 607 x 155 mm (16.75 x 23.91 x 6.12 in.)</li> </ul>		
	ULN-FM-6	<ul style="list-style-type: none"> <li>• 426 x 607 x 155 mm (16.75 x 23.91 x 6.12 in.)</li> </ul>		
ULN-FM-6i	<ul style="list-style-type: none"> <li>• 426 x 607 x 155 mm (16.75 x 23.91 x 6.12 in.)</li> </ul>			
Half rack	<ul style="list-style-type: none"> <li>• See <a href="#">Half Rack</a> on page 13.</li> </ul>			
Full rack	<ul style="list-style-type: none"> <li>• See <a href="#">Full Rack</a> on page 15.</li> </ul>			

# CM300xi-ULN Probe System

<b>Weight</b>	Probe station	Fully-automated	• With MHU301 = max. 1300 kg (2870 pounds)
		Semi-automated	• Maximum 1150 kg (2540 pounds)
	ULN-EMO-MU		• 17.7 kg (39 pounds)
	ULN-FM-4		• 15.4 kg (34 pounds)
	ULN-FM-6		• 16.1 kg (35.5 pounds)
	ULN-FM-6i		• 16.6 kg (36.5 pounds)
	Half rack (with shelves fully loaded)		• Installed max. capacity: 184.8 kg (407.4 pounds) • Max. weight per foot (4 feet): 46.2 kg (101.9 pounds)
	Full rack (with shelves fully loaded)		• Installed max. capacity: 345.8 kg (762.4 pounds) • Max. weight per foot (4 feet): 86.5 kg (190.6 pounds)
Actual weight depends on configuration. A forklift is required for moving/unpacking the station(s) and MHU301.			
<b>Shipping Dimensions (WxDxH)</b>	Probe station crate		• 1430 x 1930 x 2050 mm (56 x 76 x 81 in.)
	Loader crate		• MHU301 = 740 x 1180 x 1590 mm (29 x 46 x 63 in.)
	ULN filter modules crate		• 2 modules = 1213 x 1162 x 356 mm (47.75 x 45.75 x 14 inches) • 4 modules = 1213 x 1162 x 610 mm (47.75 x 45.75 x 24 inches)
	Rack crate		• Half rack: 1220 x 813 x 1359 mm (48 x 32 x 53.5 in.) • Full rack = 1220 x 813 x 2172 mm (48 x 32 x 85.5 in.)
	Accessories, up to 5 boxes		• Maximum size: 1400 x 1500 x 1600 mm (55 x 59 x 63 in.)
<b>Shipping Weight</b>	Station crate(s)		• ~1350 kg (2980 pounds)
	Loader crate		• MHU301 = ~200 kg (440 pounds)
	ULN filter modules crate		• 2 modules = ~188 kg (414 pounds) • 4 modules = ~385 kg (849 pounds) (Maximum weight depends on system configuration.)
	Rack crate		• Half rack = ~ 99.1 kg (218.5 pounds) • Full rack = ~ 187.5 kg (413.3 pounds)
	Accessories, up to 5 boxes		• Maximum weight depends on system configuration.

\* Standard Ambient Temperature and Pressure (SATP)

## Component Ratings

This section lists the power ratings for devices that connect to the ULN Power Conditioning Unit. For information on connecting power and equipment cables, refer to the *Ultra Low Noise Power Conditioning Unit User Guide*.

Component	Power ratings
<b>Semi-automated probe station</b>	(Includes station, controller, monitors, microscope) <ul style="list-style-type: none"> <li>• Single phase: 208-240 VAC 50/60 Hz</li> <li>• Maximum 1500 VA</li> <li>• Short circuit current rating: 5 kA (10 kA ≤ 125 VAC) (UL508 A)</li> <li>• Main connector: Grounded IEC appliance inlet C14, according to IEC 60320, UL 498, CSA C22.2 no. 42 (for cold conditions) pin-temperature 70°C, 10 A, protection class I</li> </ul>
<b>Motorized Positioner Controller (MPX)</b>	<ul style="list-style-type: none"> <li>• 100-240 VAC, 50/60 Hz</li> <li>• Max. 300 VA</li> <li>• Grounded IEC appliance inlet C14, according to IEC 60320</li> </ul>

# CM300xi-ULN Probe System

Component	Power ratings				
<b>Thermal chiller and controller</b>	<ul style="list-style-type: none"> <li>• Chiller:               <ul style="list-style-type: none"> <li>– 208 VAC 60 Hz, 2350 VA, 11.2 A</li> <li>– 230 VAC 50 Hz, 2350 VA</li> </ul> </li> <li>• Controller: 208-240 VAC, 1500 VA, 7.2 A</li> </ul>				
<b>ATT chiller and controller power plug</b>	<div style="display: flex; align-items: center;">  <p>The product is provided with a factory installed rewireable IEC plug.</p> </div>				
	<table border="1" style="width: 100%; border-collapse: collapse;"> <tr> <td style="width: 30%; padding: 2px;">Controller</td> <td style="padding: 2px;">• Connects to the dedicated socket X33 at the back of the ULN-EMO-MU</td> </tr> <tr> <td style="padding: 2px;">Chiller</td> <td style="padding: 2px;">• Connects to the dedicated socket X34 at ULN-EMO-MU</td> </tr> </table>	Controller	• Connects to the dedicated socket X33 at the back of the ULN-EMO-MU	Chiller	• Connects to the dedicated socket X34 at ULN-EMO-MU
Controller	• Connects to the dedicated socket X33 at the back of the ULN-EMO-MU				
Chiller	• Connects to the dedicated socket X34 at ULN-EMO-MU				
	Refer to the facility preparation guide for your thermal system.				
<b>MHU301 (material handling unit)</b>	<ul style="list-style-type: none"> <li>• Single phase: 100-240VAC ±10%, 50/60 Hz</li> <li>• Maximum 1000 VA</li> <li>• Short circuit current rating: 5 kA (UL508A)</li> <li>• Main connector:               <ul style="list-style-type: none"> <li>– Grounded IEC appliance inlet C14, according to IEC 60320, UL 498, CSA C22.2 no. 42 (for cold conditions) pin-temperature 70°C, 10 A, protection class I.</li> <li>– A region dependent power cord connects IEC C14 to common local power plug (1 phase, grounded).</li> </ul> </li> <li>• Facility power line fuse: 1x 16A IEC60269 class gG or 1x 15A UL248 class J (lead fuses)</li> <li>• Protection class: I (IEC 61140)</li> </ul>				

# CM300xi-ULN Probe System

## Station and MHU Dimensions



### NOTE | HINWEIS | REMARQUE

Maximum height is shown. Actual height is determined by light tower type. Microscope transport type varies depending on system configuration.

Die maximale Höhe wird angezeigt. Die tatsächliche Höhe wird durch den Lichtmasttyp bestimmt. Der Mikroskoptransporttyp variiert je nach Systemkonfiguration.

L'illustration montre la hauteur maximale. La hauteur réelle est déterminée par le type de tour d'éclairage. Le type de transport du microscope varie en fonction de la configuration du système.

## Semi-automated Probe Station Without MHU

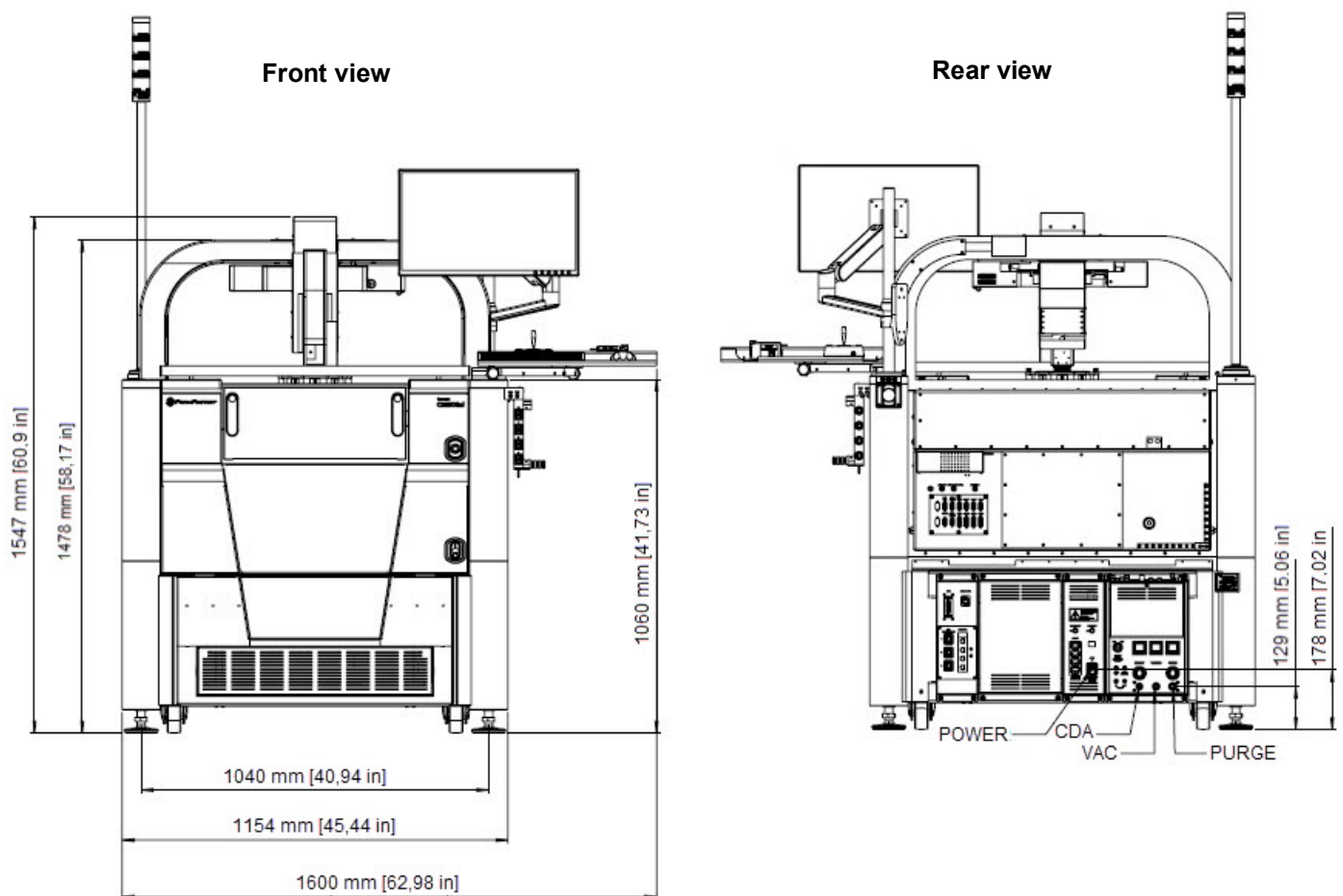

# CM300xi-ULN Probe System

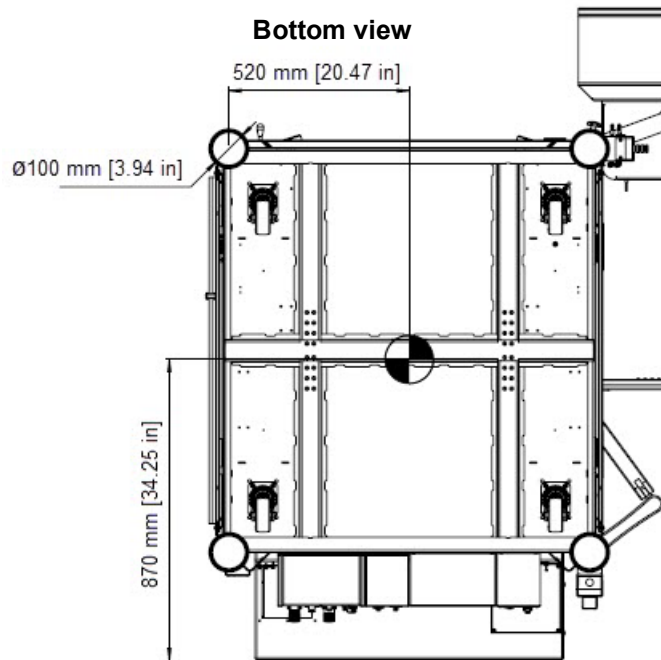
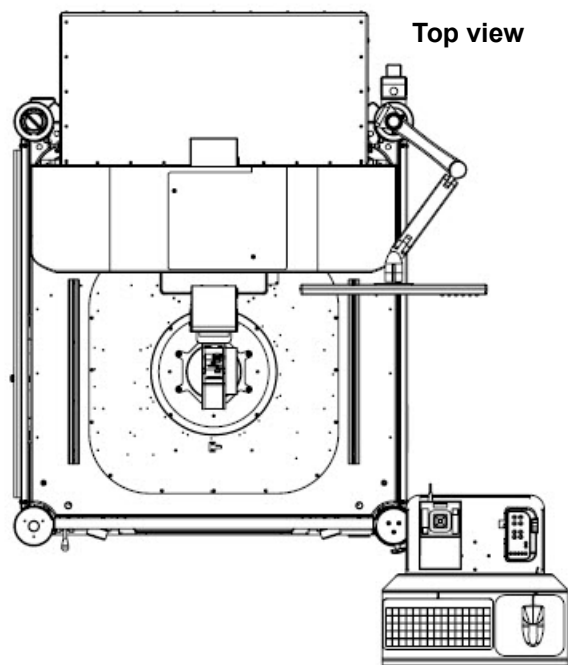

## Side views

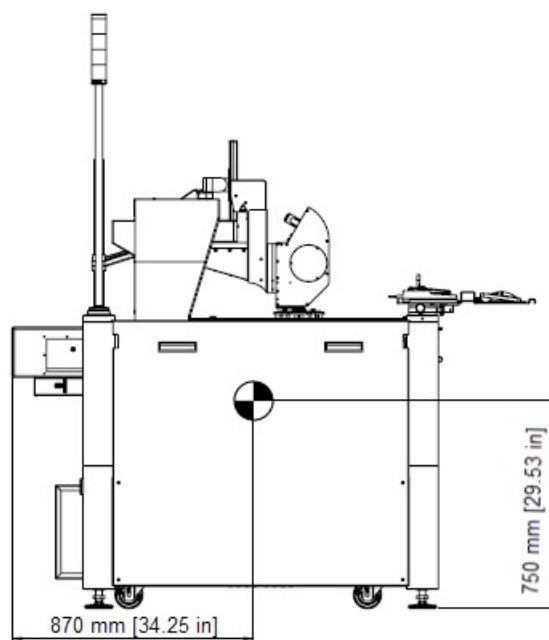
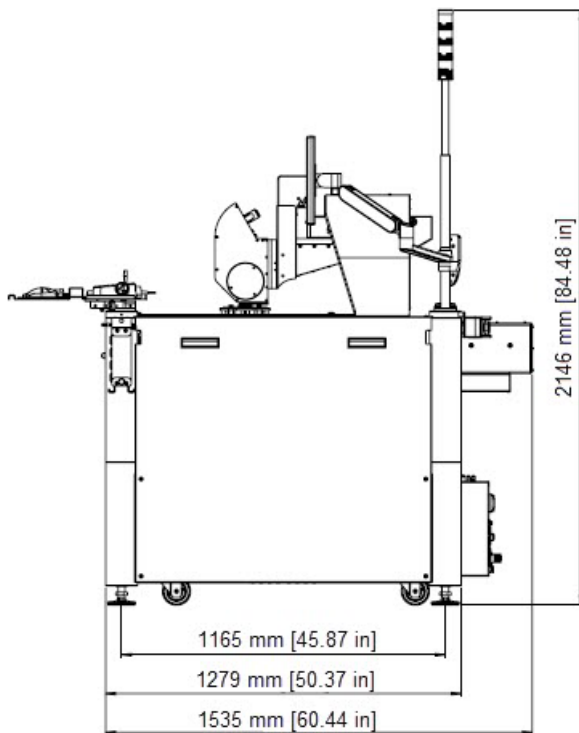



# CM300xi-ULN Probe System

Fully-Automated Probe Station with MHU301

Front view, probe station configured on the right

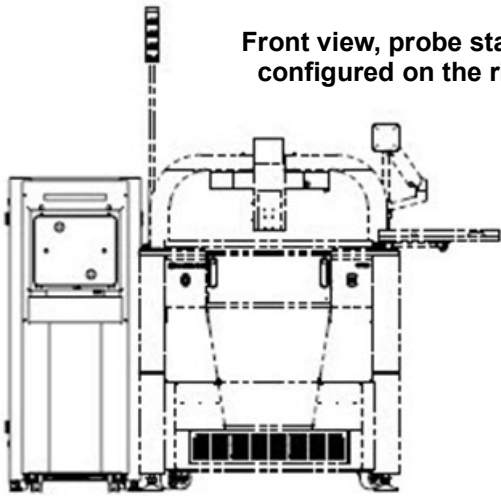

Front view, probe station configured on the left

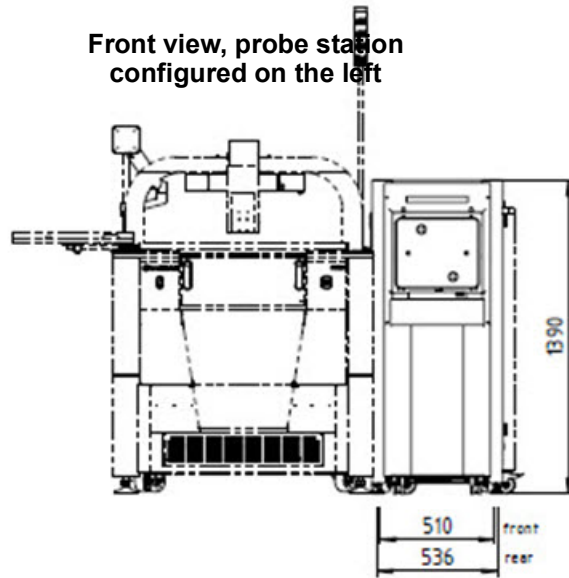

Rear view

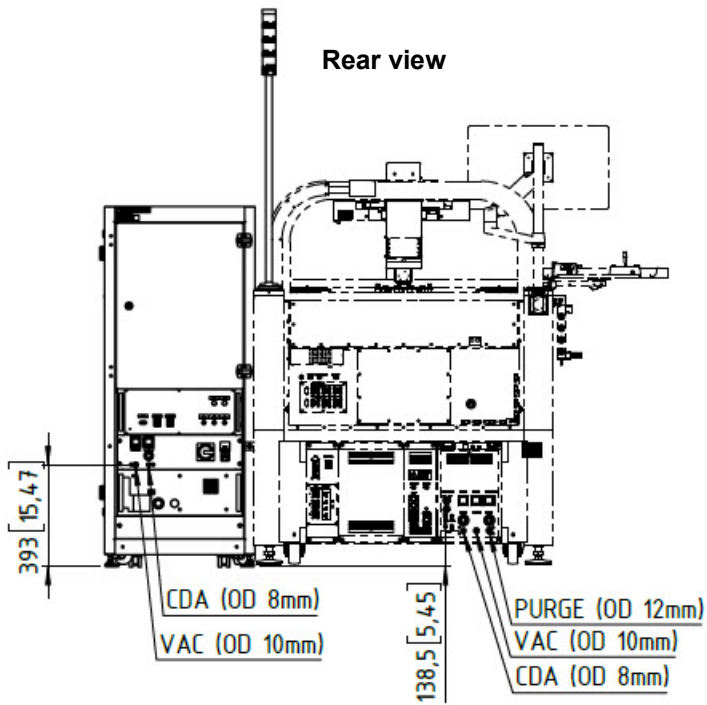

Side view

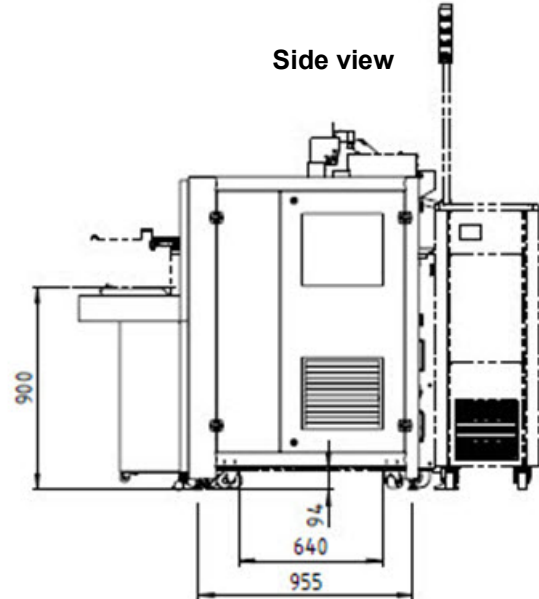

# CM300xi-ULN Probe System

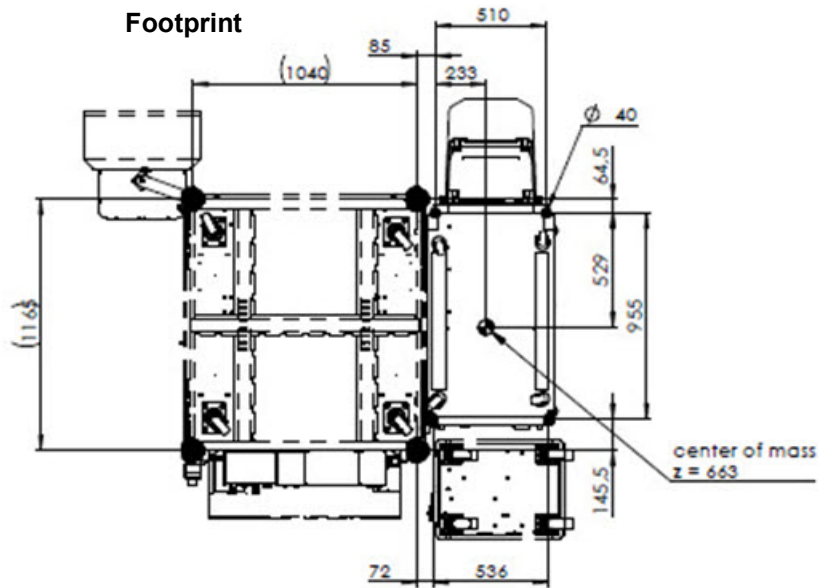

Top view, configured on the right

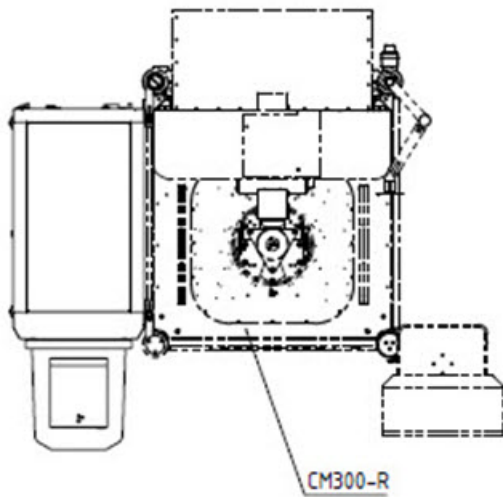

Top view, configured on the left

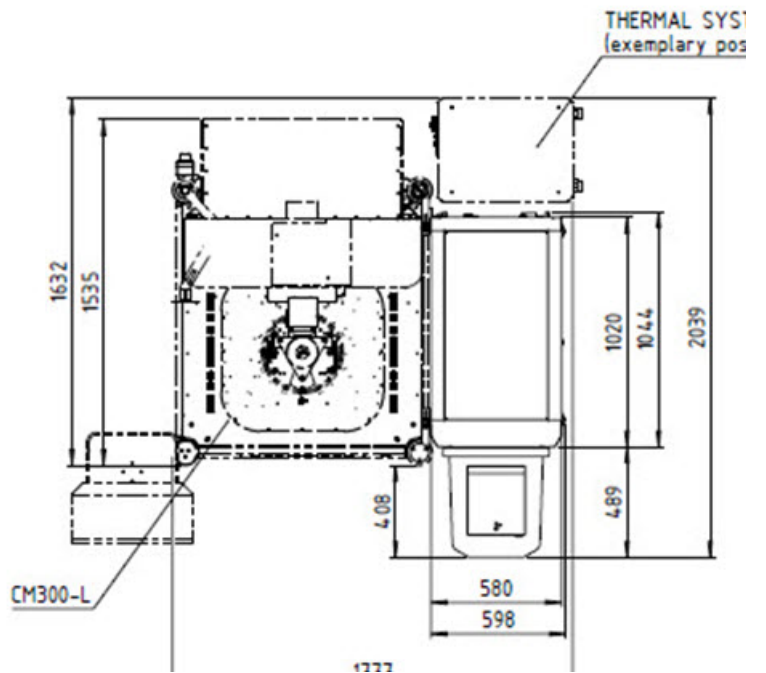

# CM300xi-ULN Probe System

## Fully-Automated Probe Station with MHU301 and Equipment Rack

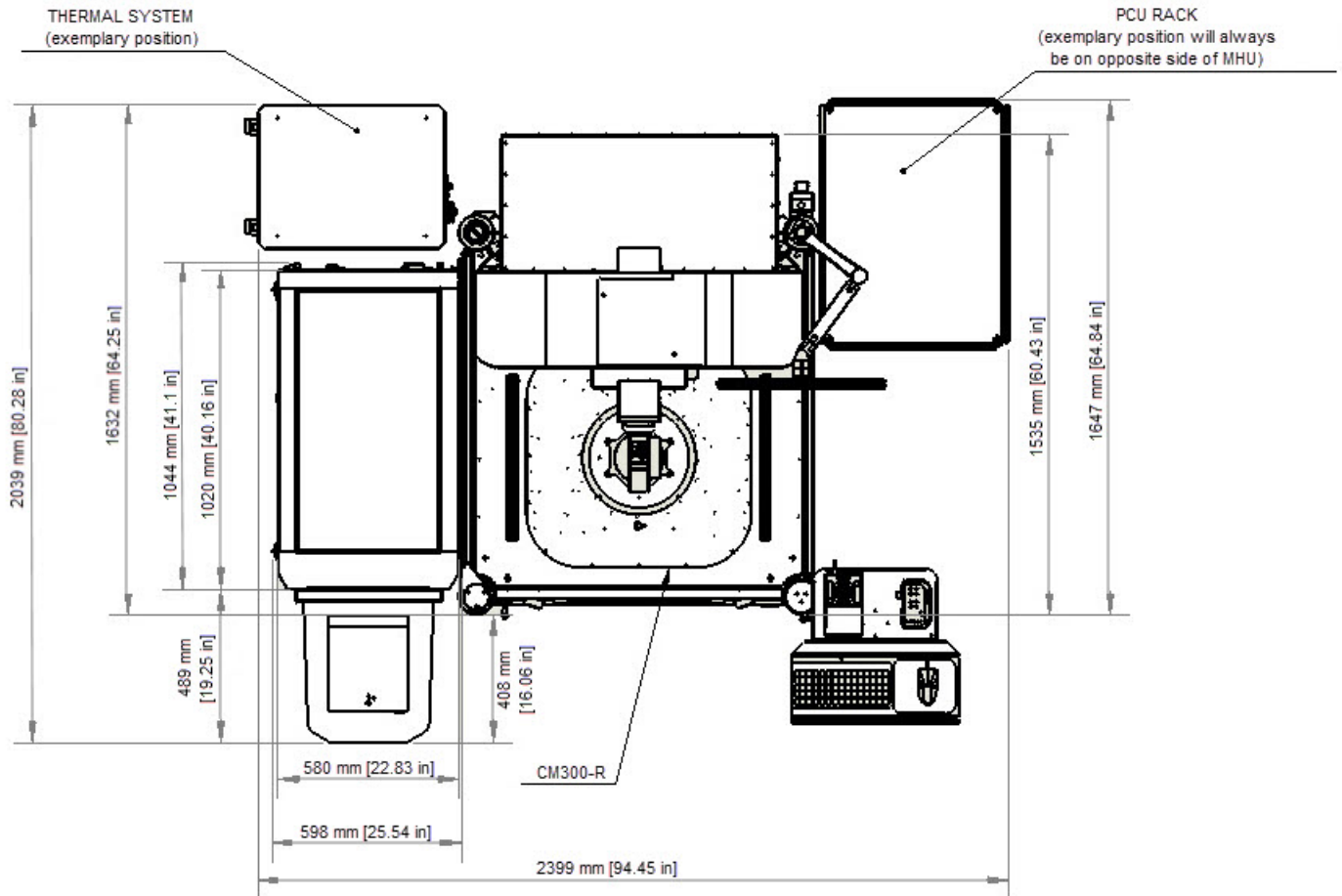

# CM300xi-ULN Probe System

---

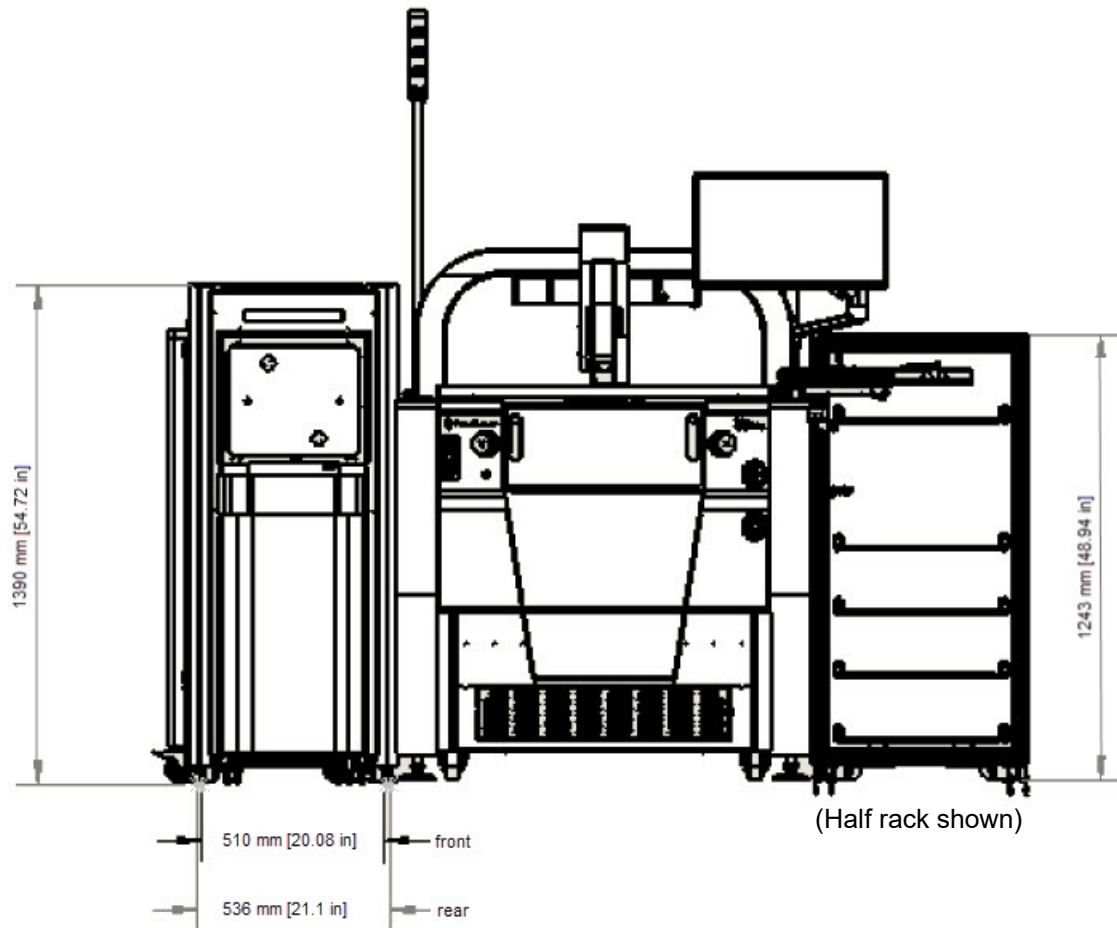

# CM300xi-ULN Probe System

## Equipment Rack Dimensions

The equipment rack is designed to hold the ULN Power Conditioning Unit modules and customer test equipment. It is available in both half and full rack configurations.

### Half Rack

Standard two module PCU (ULN-EMO-MU, ULN-FM-4), shown with two optional modules (ULN-FM-6, ULN-FM-6i) added. The half size rack includes five pre-installed shelves.

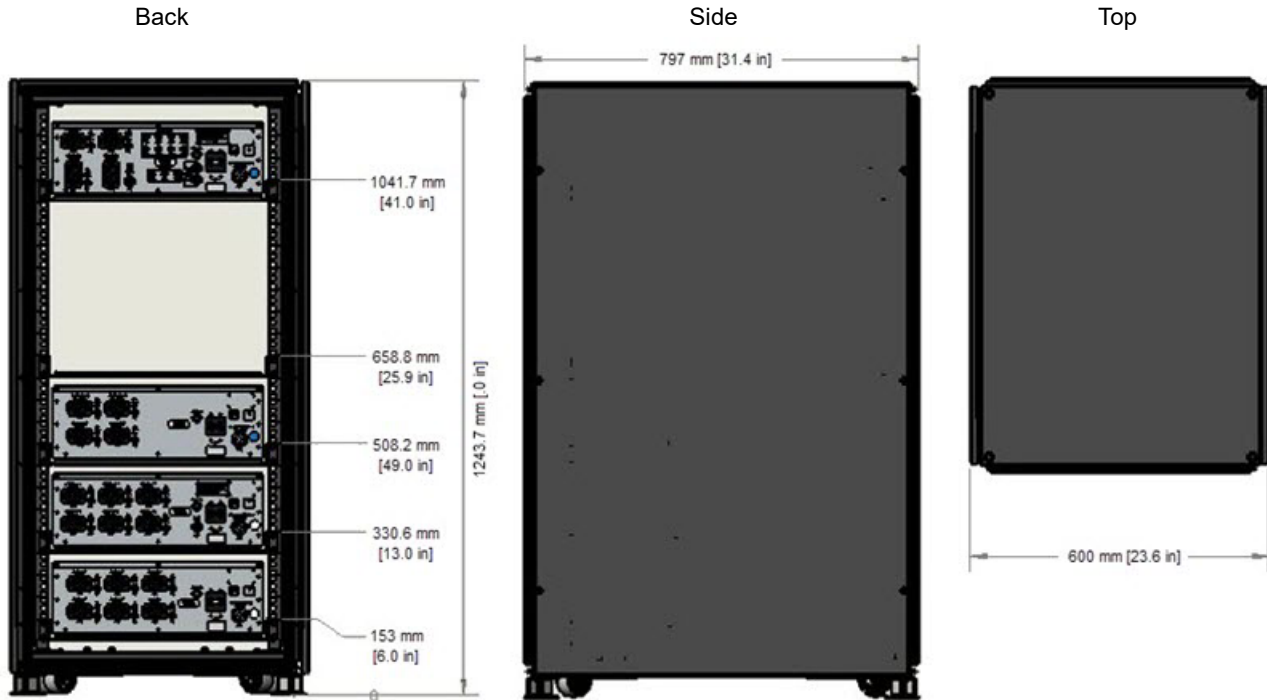

# CM300xi-ULN Probe System

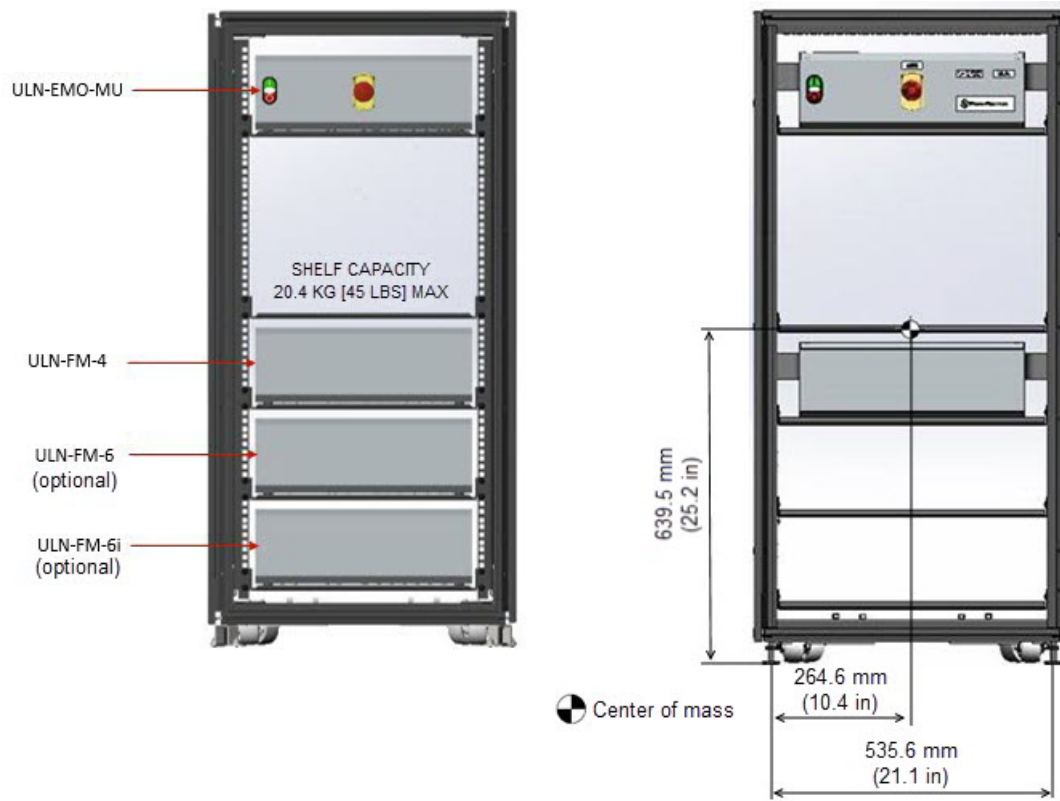

# CM300xi-ULN Probe System

## Full Rack

Standard two module PCU (ULN-EMO-MU, ULN-FM-4), shown with two optional modules (ULN-FM-6, ULN-FM-6i) added. The full size rack includes nine pre-installed shelves.

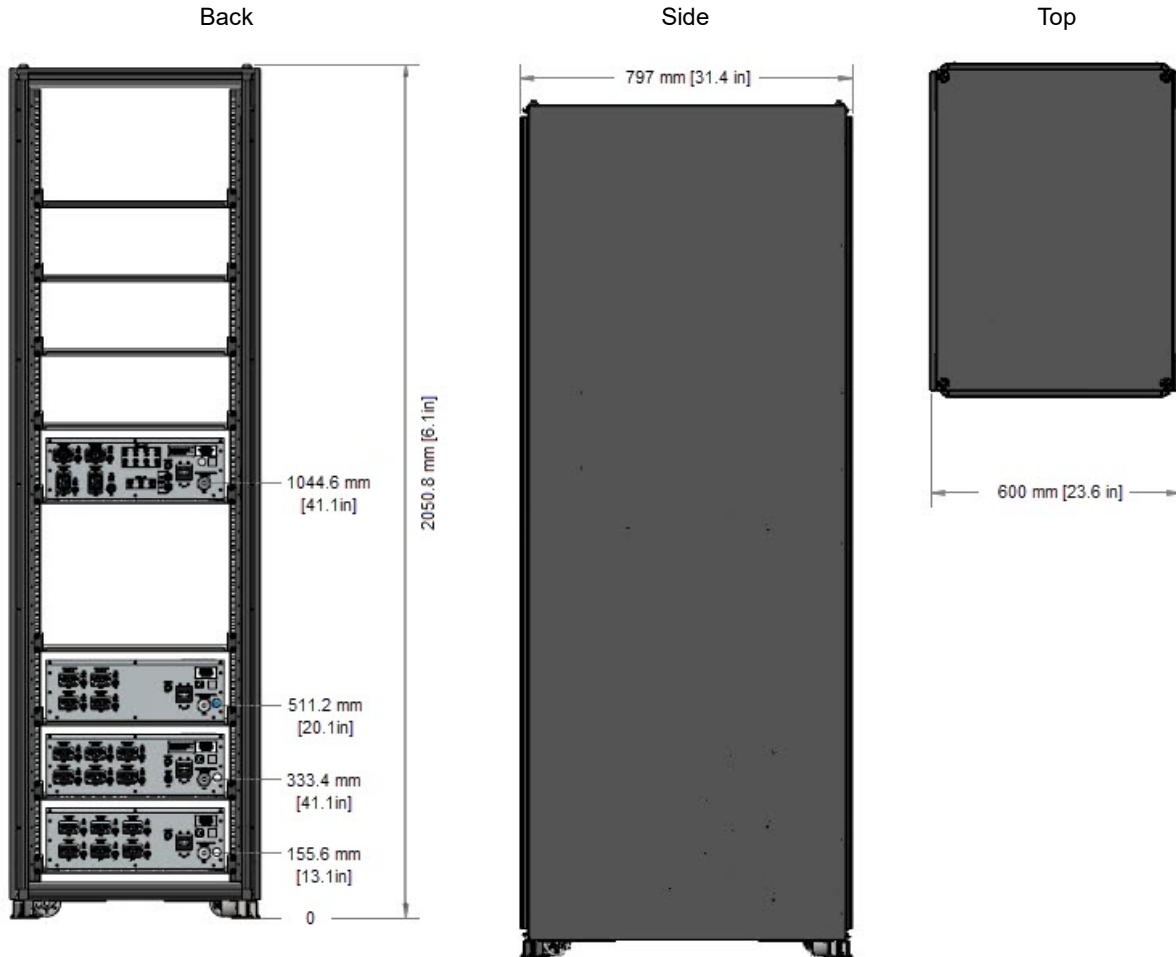

# CM300xi-ULN Probe System

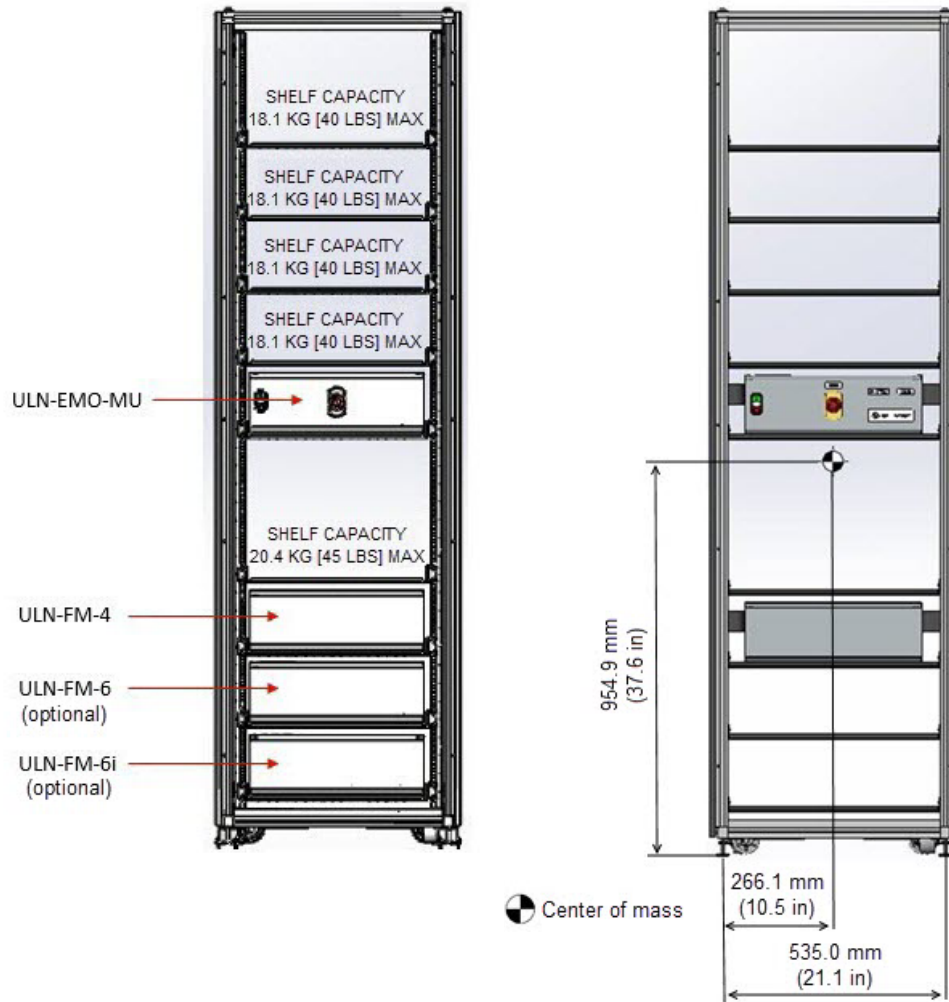



# CM300xi-ULN Probe System

## Equipment Rack Seismic Anchor Locations

For information on installing seismic restraints, see the *Ultra Low Noise Power Conditioning Unit (CM300xi-ULN) User Guide*.

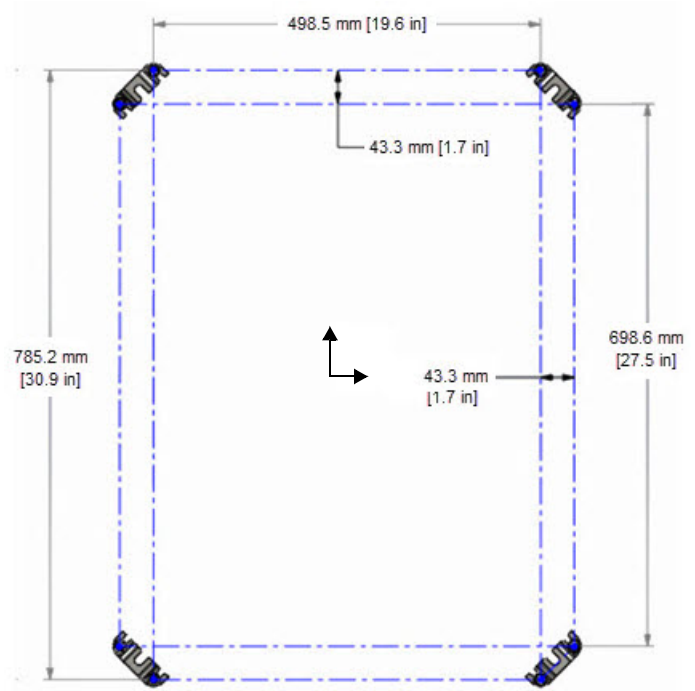
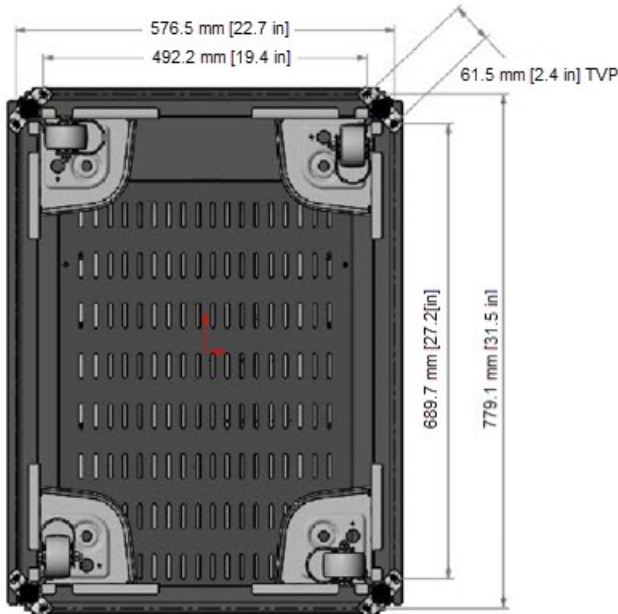

1. INDICATED DIMENSIONS ARE FOR PLACEMENT OF CONCRETE ANCHOR HOLES (8X).
2. ALL DIMENSIONS ARE IN MILLIMETERS.
3. ALL HOLES ARE TO BE DRILLED USING 6.35MM (1/4") DRILL BIT AND DEPTH IS TO BE A MINIMUM OF 28.6MM (1.125").

© Copyright 2019-2021 FormFactor, Inc. All rights reserved. No part of this document may be reproduced, transmitted or displayed in any form or by any means except as duly authorized by FormFactor, Inc. FormFactor and the FormFactor logo are trademarks of FormFactor, Inc. All other trademarks are the property of their respective owners.

### Important Notice

While the information contained herein is believed to be accurate as of the date hereof, no express or implied representations or warranties are made with respect to its accuracy or completeness. FormFactor, Inc., and its subsidiaries disclaim liability for any inaccuracies or omissions. All information is subject to change without notice.

Users are required to read and follow carefully all safety, compliance and use instructions. Users assume all loss and liability arising from the use of products in any manner not expressly authorized. The conditions and methods of use of products and information referred to herein are the entire responsibility of the user and, to the maximum extent permitted by applicable law, FormFactor, Inc., and its subsidiaries shall not be liable for any damages, losses, costs or expenses arising out of, or related to, the use thereof.

No license, express or implied, by estoppel or otherwise, under any intellectual property right is granted in connection herewith. Users shall take all actions required to avoid intellectual property infringement.

### Corporate Headquarters

7005 Southfront Road  
 Livermore, CA 94551  
 Phone: 925-290-4000  
[www.formfactor.com](http://www.formfactor.com)