

# Enerchron® 2.0

## Test Management Software



Advanced Test Creation, Execution, & Reporting Capability for Battery Cycling & Other Data-Intensive Test Applications

### Key Features

- Continuous measurement collection, monitoring, and archiving
- Powerful Test Sequence Editor that optimizes flexibility and intuitiveness
- Ability to instantly scale test sequences to other like products
- Dynamic, configurable reporting, and charting
- Ability to add new test system hardware onto the core software package
- Import and dynamically scale Drive Cycle tables
- Eliminate Post Processing data

### Application

Enerchron is a software suite ideally suited for test applications that yield extensive data over an extended period of time such as battery cycling and evaluation. It allows the creation of complex, dynamic test sequences without requiring the skills of a programmer. In addition to real-time viewing during

execution, measurements are automatically archived for review and analysis after testing has been completed. Enerchron is available with NH Research's Model 9200 Regenerative Battery Test System or can be used to control additional Battery Test Systems, NHR air-cooled loads, power supplies, temperature chambers, and data acquisition devices that measure temperature and pressure.

### Intuitive, Menu-Driven Test Sequence Editor

The heart of Enerchron is a Test Sequence Editor (Fig. 1). The Editor provides the basic framework for creating the test and analysis sequences to be executed. It uses a simple multi-tab layout with easy-to-use spreadsheet-type data entry. Sequences can be as simple or complex as needed with unlimited steps and multiple sub-sequences. This logical test sequence development environment results in minimal training necessary to create a comprehensive test package.

	Delete	Insert	Label	Action	Action Data	End Conditions	Branch	Report	Comment
1	-	+	Set HW Safety	49xx Safety	DC PM 1 Safety limits: 15.5V max for 1.0s 35A max charge for 1.0s			Create new: Logs Only Summary Report	Start one logs only and one summary report
2	-	+	Start Loop	Set Variables	Loop = [Loop] + 1			Create new: Per Loop Report	One report per cycle
3	-	+	Discharge	49xx Operation	DC PM 1 Discharge @ A=4 * (In)	WAIT TIME 0:00:30.000 IF [DC PM 1:Voltage V] < 11 GOTO <Next Step>			Discharge at 4 * In where In = C20 / 20
4	-	+	Rest After Discharge	49xx Operation	DC PM 1 Stand By	WAIT UNTIL (System:StepTime) >= 90			
5	-	+	Charge	49xx Operation	DC PM 1 Charge @ V=14.7 A=5 * (In)	WAIT UNTIL [DC PM 1:Voltage V] >= 14.1			Charge at 4 * In
6	-	+	Absorption Phase	49xx Operation	DC PM 1 Charge @ V=14.1 A=5 * (In)	WAIT UNTIL [DC PM 1:Current A] <= [C20] * 0.1			Charge at 4 * In with Vlimit = 14.1
7	-	+	Capture Ah Before Finish	Set Variables	Ah_Returned = [DC PM 1:Charge Ah]				Capture Ah @ end of CV
8	-	+	Finish Charge	49xx Operation	DC PM 1 Charge @ V=14.7 A=[C20] * 0.1	WAIT UNTIL (DC PM 1:Charge Ah) >= 1.10 * [Ah_Returned]			Finish with 10% more
9	-	+	Rest After Charge	49xx Operation	DC PM 1 Stand By	WAIT UNTIL (System:StepTime) >= 90			Rest after charge
10	-	+	End Of Loop?			IF [Loop] < 3 GOTO Start Loop IF [Loop] >= 3 GOSUB End Test LOG TO REPORTS (Loop_Charge_Ah_Discharge_Ah)			Cycle 3 times

Figure 1 - Enerchron sequence editor

## Measurements Continuously Collected, Time-Stamped & Archived

Enerchron is designed to be used with a measurement-archiving server (Fig. 2). The measurements are collected, time-stamped, and archived separate from any test-specific routines. This feature provides multiple advantages when compared to in-sequence data acquisition and logging.

First, it allows any number of separate test sequences to share the readings from a common measurement channel. For example, the common water bath temperature used when testing multiple batteries can be measured with a single temperature channel rather than requiring a measurement channel for each test sequence.

Second, measurements from any test instrument can be displayed on a single screen. This can be useful in monitoring the progress of a test or performing a failure analysis by reviewing measurements taken by other test channels at the time of the failure.

Finally, Enerchron can use archived measurements to generate multiple reports (engineering, quality, and customer) in parallel with each containing a separate level of measurement detail. If the test reports are missing the desired detail, the archive provides a historical view for the test (Fig. 3).

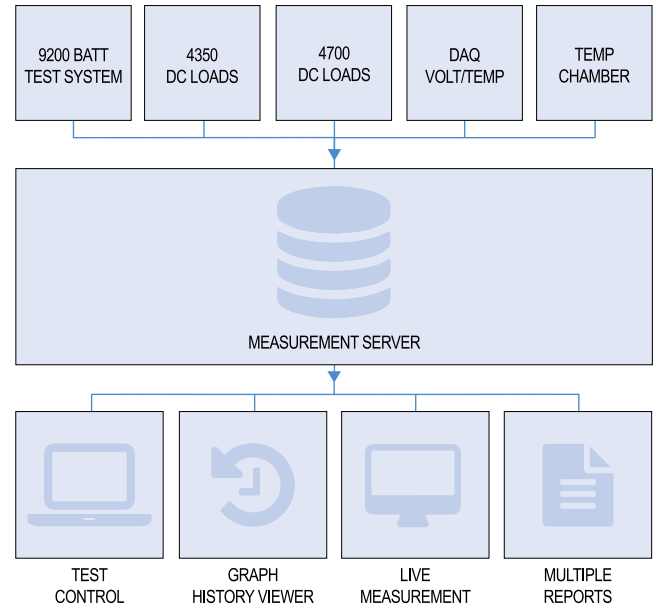

Figure 2 - Enerchron Measurement Server

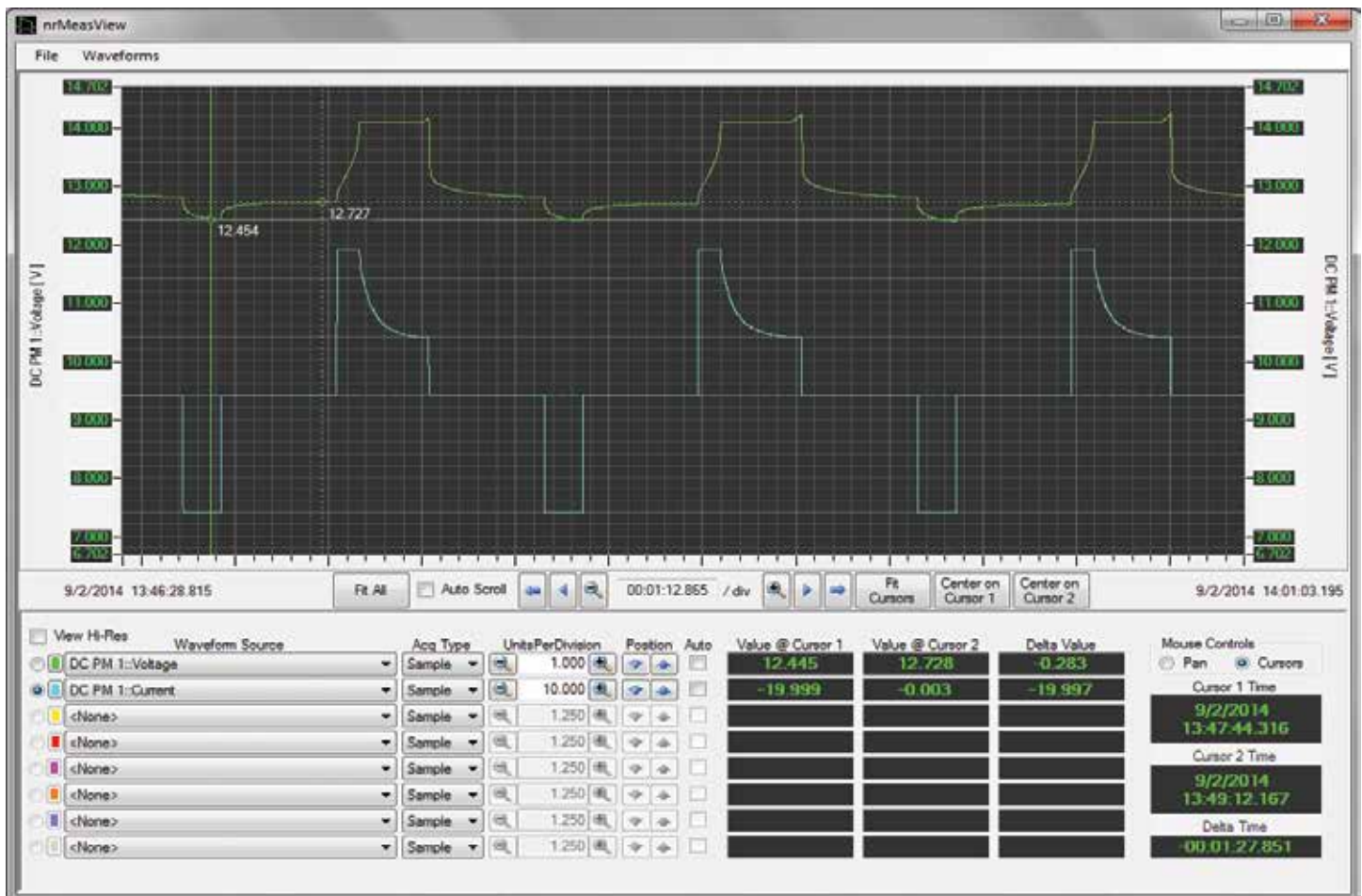

Figure 3 - Enerchron showing historic graphical views.

## Scalable Test Sequencing

A key structural element of Enerchron is adaptive sequencing (Fig. 4). That is, a test sequence can be created with variables rather than hard-coded values. Then, those variables can be modified dynamically to adapt the program to similar UUTs. With this capability, the test sequence can be written using the

same language and template used in a printed industry standard or a written test procedure. There is never a need to rewrite the template again, only to add the new UUT test parameter information. The end result is saving significant time in new test sequence preparation.

3	-	+	Discharge	49xx Operation	DC PM 1 Discharge @ $A=4 * \{In\}$	WAIT TIME 0:00:30.000 IF {DC PM 1:Voltage V} < 11 GOTO <Next Step>
---	---	---	-----------	-------------------	--	---

Figure 4 - Test sequence step 3 of Fig. 1

## Import Drive Cycles

Drive cycles such as FUDs, US06, NEDC, EUDC/EUDCL are standard patterns which represent the power profile a vehicle encounters when it is used under real-world conditions. Similarly, Aerospace and Grid-Storage use standard cycling patterns to emulate the real-world characteristics when testing these applications.

Enerchron can import drive cycle tables and use variables to automatically scale them to product-specific or test-specific

settings. For example, the same Federal Urban Drive Cycle (FUDs) table may be used to test the battery for a battery electric vehicle (BEV) and a battery for a plug-in-hybrid electric vehicle (PHEV) (Fig. 5). The profile is scaled differently using a static scaling factor for the BEV and dynamically scaled for the PHEV to account for the power generated by the internal combustion engine (ICE). Enerchron makes this straight forward to accomplish.

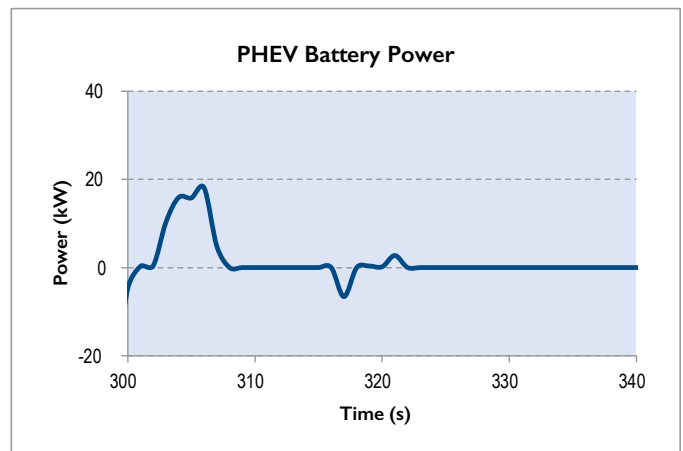
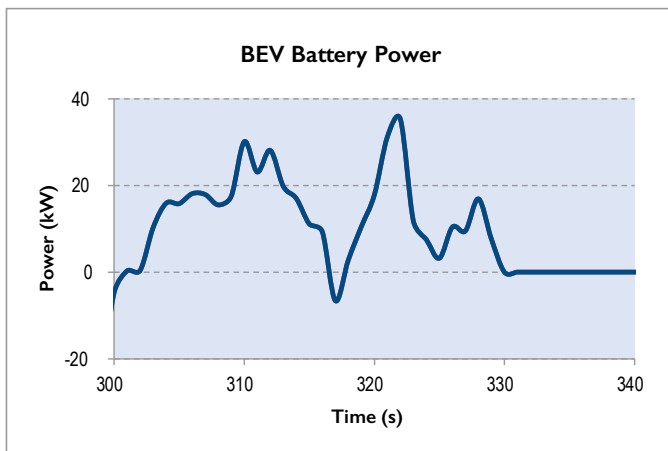

Figure 5 - Automatically scaled drive cycles (BEV & PHEV)

## Data Driven Testing

Battery standards are starting to require data-driven sequence control (Fig. 6). For example, in start stop applications, the amount of recharge energy applied to the battery depends on previous test cycle history. By using variables and expressions,

Enerchron allows the test developer to use the same data labels, formulas, and end condition statements found in these dynamic data-driven test standards.

8	-	+	Finish Charge	49xx Operation	DC PM 1 Charge @ V=14.7 A={C20} * 0.1	WAIT UNTIL {DC PM 1:Charge Ah} >= 1.10 * {Ah_Returned}
---	---	---	---------------	-------------------	--	--

Figure 6 - Test sequence step 8 of Fig. 1

## Eliminate Post-Processing

Measurement data is good, battery knowledge is better. To obtain battery knowledge, engineers often must data-mine and post-process the measurements taken by a battery test sequence (Fig. 7). This process takes considerable time and technical resources. By using variables, Enerchron can store key points of information and perform the calculations automatically (Fig. 8). These calculations can then be logged to a data file allowing every point of interest to be calculated during the actual test. More timely test decisions can often be made through this real-time knowledge of UUT behavior.

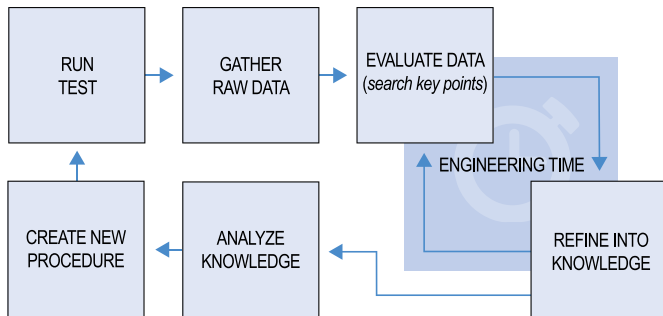

Figure 7 - Typical battery testing cycle

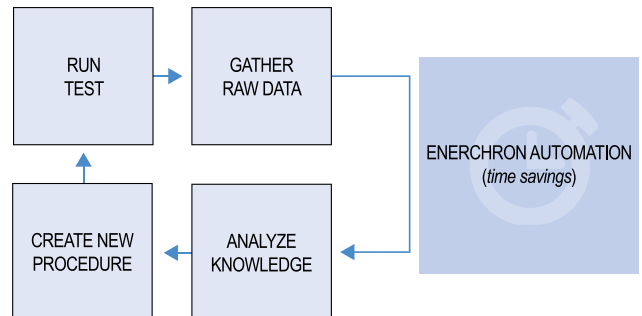

Figure 8 - Enerchron battery testing cycle

## Tester Configuration Flexibility

Within the Enerchron test environment, configuration flexibility along with future enhancements are achieved through Plug-ins (Fig. 9). Plug-ins are software components for new testing features unique to each test station. They may include control of test hardware, test algorithms, test channels, measurement channels, or UUT communication protocols. Plug-ins may be supplied by NHR for standard options or written by the user for new hardware enhancements such as integration of temperature chambers or temperature measurements. Because they are independent of the core Enerchron application, plug-ins can be developed without requiring a new version of Enerchron supplied by NHR, thereby providing the user independence to supplement tester configuration in the future.

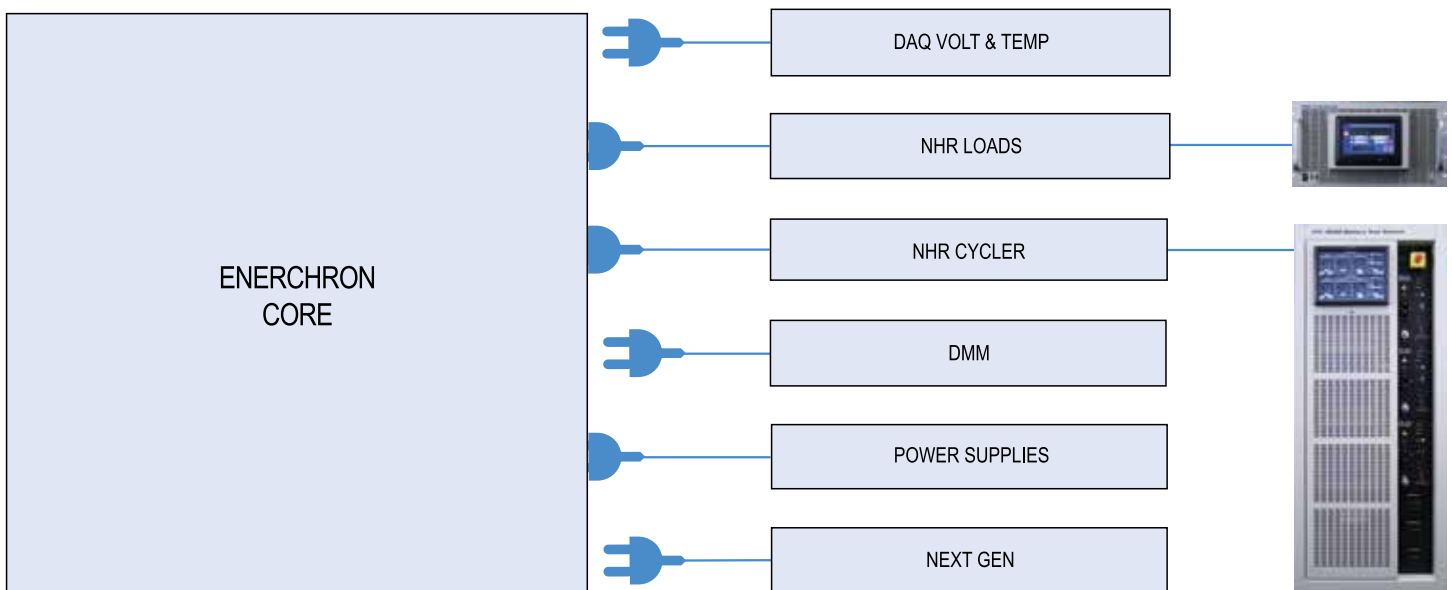

Figure 9 - Enerchron core & plug-in expansion