



Sorensen

SGe Series DC Power Supplies

Operation Manual

About AMETEK

AMETEK Programmable Power, Inc., a unit of AMETEK Electronic Instruments Group (a division of AMETEK, Inc), is a global leader in the design and manufacture of precision, programmable power supplies for R&D, test and measurement, process control, power bus simulation and power conditioning applications across diverse industrial segments. From bench-top supplies to rack-mounted industrial power subsystems, AMETEK Programmable Power is the proud manufacturer of Elgar, Sorensen, California Instruments brand power supplies and electronic loads.

AMETEK, Inc. is a leading global manufacturer of electronic instruments and electromechanical devices with annualized sales of \$3.6 billion. The company has over 14,000 colleagues working at more than 120 manufacturing facilities and more than 80 sales and service centers in the United States and around the world.

Trademarks

AMETEK is a registered trademark of AMETEK, Inc.

Other trademarks, registered trademarks, and product names are the property of their respective owners and are used herein for identification purposes only.

Notice of Copyright

SGe Series DC Power Supplies Operation Manual © 2016, AMETEK Programmable Power, Inc., All rights reserved.

Exclusion for Documentation

UNLESS SPECIFICALLY AGREED TO IN WRITING, AMETEK PROGRAMMABLE POWER, INC. ("AMETEK")

(a) MAKES NO WARRANTY AS TO THE ACCURACY, SUFFICIENCY OR SUITABILITY OF ANY TECHNICAL OR OTHER INFORMATION PROVIDED IN ITS MANUALS OR OTHER DOCUMENTATION.

(b) ASSUMES NO RESPONSIBILITY OR LIABILITY FOR LOSSES, DAMAGES, COSTS OR EXPENSES, WHETHER SPECIAL, DIRECT, INDIRECT, CONSEQUENTIAL OR INCIDENTAL, WHICH MIGHT ARISE OUT OF THE USE OF SUCH INFORMATION. THE USE OF ANY SUCH INFORMATION WILL BE ENTIRELY AT THE USER'S RISK, AND

(c) REMINDS YOU THAT IF THIS MANUAL IS IN ANY LANGUAGE OTHER THAN ENGLISH, ALTHOUGH STEPS HAVE BEEN TAKEN TO MAINTAIN THE ACCURACY OF THE TRANSLATION, THE ACCURACY CANNOT BE GUARANTEED. APPROVED AMETEK CONTENT IS CONTAINED WITH THE ENGLISH LANGUAGE VERSION, WHICH IS POSTED AT WWW.PROGRAMMABLEPOWER.COM.

Date and Revision

March 2016, Rev B

Part Number

M551443-01

Contact Information

Telephone: 800 733 5427 (toll free in North America)
858 450 0085 (direct)

Fax: 858 458 0267

Email: sales.ppd@ametek.com
sorensen.ppd@ametek.com

Web: www.programmablepower.com

Product Family: **SGe Series DC Power Supplies**

Warranty Period: **Three Years**

Warranty Terms

AMETEK Programmable Power, Inc. (“AMETEK”) provides this written warranty covering the Product stated above, and if the Buyer discovers and notifies AMETEK in writing of any defect in material or workmanship within the applicable warranty period stated above, then AMETEK may, at its option: repair or replace the Product; or issue a credit note for the defective Product; or provide the Buyer with replacement parts for the Product.

The Buyer will, at its expense, return the defective Product or parts thereof to AMETEK in accordance with the return procedure specified below. AMETEK will, at its expense, deliver the repaired or replaced Product or parts to the Buyer. Any warranty of AMETEK will not apply if the Buyer is in default under the Purchase Order Agreement or where the Product or any part thereof:

- is damaged by misuse, accident, negligence or failure to maintain the same as specified or required by AMETEK;
- is damaged by modifications, alterations or attachments thereto which are not authorized by AMETEK;
- is installed or operated contrary to the instructions of AMETEK;
- is opened, modified or disassembled in any way without AMETEK’s consent; or
- is used in combination with items, articles or materials not authorized by AMETEK.

The Buyer may not assert any claim that the Products are not in conformity with any warranty until the Buyer has made all payments to AMETEK provided for in the Purchase Order Agreement.

Product Return Procedure



1. Request a Return Material Authorization (RMA) number from the repair facility (must be done in the country in which it was purchased):
 - In the USA, contact the AMETEK Repair Department prior to the return of the product to AMETEK for repair:
 - Telephone: 800-733-5427, ext. 2295 or ext. 2463 (toll free North America) 858-450-0085, ext. 2295 or ext. 2463 (direct)
 - Outside the USA, contact the nearest Authorized Service Center (ASC). A full listing can be found either through your local distributor or our website, www.programmablepower.com, by clicking Support and going to the Service Centers tab.
2. When requesting an RMA, have the following information ready:
 - Model number
 - Serial number
 - Description of the problem

Note: Unauthorized returns will not be accepted and will be returned at the shipper’s expense.

Note: A returned product found upon inspection by AMETEK, to be in specification is subject to an evaluation fee and applicable freight charges

IMPORTANT SAFETY INSTRUCTIONS

Before applying power to the system, verify that your product is configured properly for your particular application.

	<p>WARNING!</p> <p>Hazardous voltages might be present when covers are removed. Qualified personnel must use extreme caution when servicing this equipment. Circuitry, test points, and output voltages might be floating with respect to chassis ground. Do not touch electrical circuits, and use appropriately rated test equipment. A safety ground wire must be connected from the chassis to the AC mains input when servicing this equipment.</p>
	<p>WARNING!</p> <p>This equipment contains ESD sensitive input/output connection ports. When installing equipment, follow ESD safety procedures. Electrostatic discharges might cause damage to the equipment.</p>

Only *qualified personnel*, who understand and deal with attendant hazards in power supplies, are allowed to perform installation and servicing.

Ensure that the AC mains input ground is connected properly to the chassis safety ground connection. Similarly, other power ground lines, including those to application and maintenance equipment, *must* be grounded properly for both personnel and equipment safety. Always ensure that facility AC mains input is de-energized prior to connecting or disconnecting any cable.

In normal operation from the front panel, the operator does not have access to hazardous voltages within the chassis. However, depending on the application configuration, **HIGH VOLTAGES HAZARDOUS TO HUMAN SAFETY** might be normally generated on the output terminals. The user must ensure that the output power lines are labeled properly as to the safety hazards and that any possibility for inadvertent contact with hazardous voltages is eliminated.

Guard against risks of electrical shock during open cover checks by not touching any portion of the electrical circuits. Even when power is off, capacitors may retain an electrical charge. Use safety glasses during open cover checks to avoid personal injury by any sudden component failure.

Neither AMETEK Programmable Power Inc., San Diego, California, USA, nor any of the subsidiary sales organizations can accept any responsibility for personnel, material or injury, loss or damage that results from improper use of the equipment and accessories.

SAFETY SYMBOLS



WARNING: Electrical Shock Hazard



HAZARD: Strong oxidizer



GENERAL WARNING/CAUTION: Read the accompanying message for specific information.



BURN HAZARD: Hot Surface Warning. Allow to cool before servicing.



DO NOT TOUCH: Touching some parts of the instrument without protection or proper tools could result in damage to the part(s) and/or the instrument.



TECHNICIAN SYMBOL: All operations marked with this symbol are to be performed by qualified maintenance personnel only.



ELECTRICAL GROUND: This symbol inside the instrument marks the central safety grounding point for the instrument.

FCC NOTICE

This equipment has been tested and found to comply with the limits for a Class A digital device, pursuant to part 15 of the FCC Rules. These limits are designed to provide reasonable protection against harmful interference when the equipment is operated in a commercial environment.

This equipment generates, uses, and can radiate radio frequency energy and, if not installed and used in accordance with the instruction manual, may cause harmful interference to radio communications. Operation of this equipment in a residential area is likely to cause harmful interference in which case the user will be required to correct the interference at his own expense.

ABOUT THIS MANUAL AND REGULATORY COMPLIANCE

This manual has been written for the Sorensen SGe Series of power supplies, which have been designed and certified to meet the Low Voltage and Electromagnetic Compatibility Directive Requirements of the European Community.

These models have been designed and tested to meet the Electromagnetic Compatibility directive (European Council directive 2004/108/EC; generally referred to as the EMC directive) and to the requirements of the Low Voltage directive (European Council directive 2006/95/EC, 93/68/EEC, dated 22 July 1993). In addition these models have been found compliant with FCC 47 CFR Part 15, Subpart B107(e) Class A, 109(g) Class A.

Since the Low Voltage Directive is to ensure the safety of the equipment operator, universal graphic symbols have been used both on the unit itself and in this manual to warn the operator of potentially hazardous situations (see Safety Instruction page).

CONTENTS

SECTION 1 OVERVIEW	1-1
1.1 General Description.....	1-1
1.2 Specifications.....	1-3
1.2.1 Environmental Characteristics	1-3
1.2.2 Electrical Characteristics.....	1-3
1.2.3 SGe Series Voltage and Current Specifications	1-7
1.2.4 Physical Characteristics.....	1-8
SECTION 2 INSTALLATION	2-1
2.1 Inspection	2-1
2.2 Contents of Shipment.....	2-1
2.3 Location and Mounting	2-2
2.3.1 Rack Mounting	2-3
2.3.2 K550212-01 ASSEMBLY STEPS (OPTION KIT for 3U models).....	2-4
2.3.3 K550213-01 ASSEMBLY STEPS (OPTION KIT for 6U models).....	2-6
2.3.4 Chassis Removal from Rack.....	2-7
2.4 Input/Output Connections.....	2-8
2.5 Wire selection.....	2-11
2.5.1 Wire Size.....	2-11
2.6 Load Considerations	2-14
2.6.1 Inductive and STORED-ENERGY Loads	2-14
2.7 Outline and Installation Drawings	2-15
SECTION 3 OPERATION	3-1
3.1 Introduction	3-1
3.1.1 Front/rear Panels	3-1
3.2 Shaft Lock (Option).....	3-9
3.3 Front Panel Operation	3-10
3.3.1 Initial Setup	3-10
3.3.2 constant-Voltage Mode Operation	3-11
3.3.3 Constant-Current Mode Operation	3-12

- 3.3.4 Overvoltage Protection3-13
- 3.4 Remote Analog Control Connector (J1)..... 3-14**
- 3.5 Remote Current Programming 3-18**
 - 3.5.1 Remote Current Programming by Resistance3-18
 - 3.5.2 Remote Current Programming by Voltage Source3-19
- 3.6 Remote Voltage Programming..... 3-20**
 - 3.6.1 Remote Voltage Programming by Resistance.....3-20
 - 3.6.2 Remote Voltage Programming by Voltage Source3-21
- 3.7 Remote Overvoltage Protection Programming 3-22**
- 3.8 Remote Output ON/OFF Control..... 3-23**
 - 3.8.1 Remote Output ON/OFF by Contact Closure3-23
 - 3.8.2 Remote Output ON/OFF Control by External Source.....3-23
 - 3.8.3 Remote Shutdown (S/D).....3-24
- 3.9 Remote Sensing..... 3-25**
- 3.10 Floating and Polarized Output..... 3-28**
- 3.11 Parallel and Series Operation 3-29**
 - 3.11.1 Parallel Operation3-29
 - 3.11.2 Series Operation3-31

SECTION 4 CALIBRATION AND VERIFICATION... 4-1

- 4.1 Introduction 4-1**
 - 4.1.1 Calibration and Verification Cycle4-1
 - 4.1.2 Preparation4-1
- 4.2 Calibration and Verification Procedures..... 4-2**
 - 4.2.1 Constant-Current Mode4-3
 - 4.2.2 Constant-Voltage Mode4-3
 - 4.2.3 Resistive-Control Programming Current Sources4-4
- 4.3 Remote Isolated Analog Interface (Option) Calibration and Verification Procedures 4-5**
 - 4.3.1 Constant-Current Mode4-5
 - 4.3.2 Constant-Voltage Mode4-6

SECTION 5 MAINTENANCE 5-1

- 5.1 Introduction 5-1**
- 5.2 Preventive Maintenance 5-1**
- 5.3 Fuses..... 5-3**

LIST OF TABLES

Table 2–1. Maximum AC Current Ratings, PFC Models	2-9
Table 2–2. Maximum AC Current Ratings, Non-PFC Models	2-9
Table 2–3. Input/Output Connectors	2-9
Table 2–4. Input Terminal Connections.....	2-10
Table 2–5. Output Terminal Connections.....	2-10
Table 2–6. Recommended Lugs	2-10
Table 2–7. Recommended Sense Connector Tools.....	2-10
Table 2–8. Minimum Wire Size.....	2-11
Table 2–9. Wire Resistance and Voltage Drop, 20°C	2-13
Table 3–1. Front Panel Controls and Indicators	3-2
Table 3–2. Rear Panel Connectors and Controls, Standard	3-6
Table 3–3. Rear Panel Connectors and Controls, GPIB Option.....	3-7
Table 3–4. Rear Panel Connectors and Controls, Ethernet Option.....	3-8
Table 3–5. Analog Control Connector (J1), Designations and Functions.....	3-17
Table 4.1. Fuse Ratings	5-3

LIST OF FIGURES

Figure 1-1. Model Number Decoding	1-2
Figure 2-1. Rack Mount Assembly for 3U Models	2-4
Figure 2-2. Rack Mount Assembly for 6U Models	2-6
Figure 2-3. Diode Connection.....	2-14
Figure 2-4. Installation Drawing, 3U Models 10V-30V.....	2-16
Figure 2-5. Installation Drawing, 3U Models 40V-600V.....	2-17
Figure 2-6. Installation Drawing, 3U Models 800V-1000V.....	2-18
Figure 2-7. Installation Drawing, 6U Models 20 kW to 30 kW	2-19
Figure 2-8. Rear Panel, Standard,3U Models 10V-30V	2-20
Figure 2-9. Rear Panel, GPIB Option, 3U Models 10V-30V	2-21
Figure 2-10. Rear Panel, Ethernet Option, 3U Models 10V-30V.....	2-22
Figure 2-11. Rear Panel, Standard, 3U Models 40V-600V	2-23
Figure 2-12. Rear Panel, GPIB Option, 3U Models 40V-600V.....	2-24
Figure 2-13. Rear Panel, Ethernet Option, 3U Models 800V and 1000V	2-25
Figure 2-14. Rear Panel, Standard, 6U Models 20kW-30kW	2-26
Figure 2-15. Rear Panel, GPIB Option, 6U Models 20kW-30kW	2-27
Figure 2-16. Rear Panel, Ethernet Option, 6U Models 20kW-30kW	2-28
Figure 2-17. Instructions for Assembly of AC and DC Covers	2-29
Figure 3-1. Front Panel Controls and Indicators (3U Model Shown).....	3-1

Figure 3-2. Rear Panel Interface, Standard, 3U Models 10V-30V	3-3
Figure 3-3. Rear Panel Interface, GPIB Option, 3U Models 10V-30V	3-3
Figure 3-4. Rear Panel Interface, Ethernet Option, 3U Models 10V-30V	3-3
Figure 3-5. Rear Panel Interface, Standard, 3U Models 40V-600V	3-4
Figure 3-6. Rear Panel Interface, GPIB Option, 3U Models 40V-600V	3-4
Figure 3-7. Rear Panel Interface, Ethernet Option, 3U Models 800V and 1000V	3-4
Figure 3-8. Rear Panel Interface, Standard, 6U Models 20kW-30kW	3-5
Figure 3-9. Rear Panel Interface, GPIB Option, 6U Models 20kW-30kW	3-5
Figure 3-10. Rear Panel Interface, Ethernet Option, 6U Models 20kW-30kW	3-5
Figure 3-11. Shaft Lock	3-9
Figure 3-12. Analog Control Connector (J1) Pin-Out	3-15
Figure 3-13. Remote Current Programming Using Resistance	3-18
Figure 3-14. Remote Current Programming Using 0-5 VDC or 0-10 VDC Source.....	3-19
Figure 3-15. Remote Voltage Programming Using Resistance	3-20
Figure 3-16. Remote Voltage Programming Using 0-5 VDC or 0-10 VDC Source	3-21
Figure 3-17. Remote Overvoltage Programming Using DC Source	3-22
Figure 3-18. Remote Output ON/OFF Control by Contact Closure	3-23
Figure 3-19. Remote Isolated Output ON/OFF Using AC or DC Source.....	3-23
Figure 3-20. Remote Output ON/OFF Using Isolated TTL/CMOS Source	3-24
Figure 3-21. Remote Shutdown Using DC Voltage Source.....	3-24
Figure 3-22. Remote Voltage Sensing Network	3-25
Figure 3-23. Remote Sense Connection at the Load, 10V-800V Models.....	3-26
Figure 3-24. Remote Sense Connection at the Load, 1000V Model	3-27
Figure 3-25. Parallel Connection and Remote Sense	3-31
Figure 3-26. Series Connection with Anti-Parallel Diodes	3-32
Figure 4-1. Potentiometer Locations	4-7

SECTION 1 OVERVIEW

1.1 GENERAL DESCRIPTION

The Sorensen SGe Series are general purpose power supplies designed specifically for systems applications and laboratory test requiring programmable DC sources with good performance characteristics, such as accuracy, regulation, and ripple/noise. These power supplies are constant-current/constant-voltage supplies with an automatic crossover feature.

A variety of user interfaces are available, ranging from manual front panel control and standard non-isolated remote analog control, to optional GPIB, Ethernet or isolated remote analog control.

Refer to [Figure 1-1](#) for decoding of the SGe Series model number.

Figure 1-1. Model Number Decoding

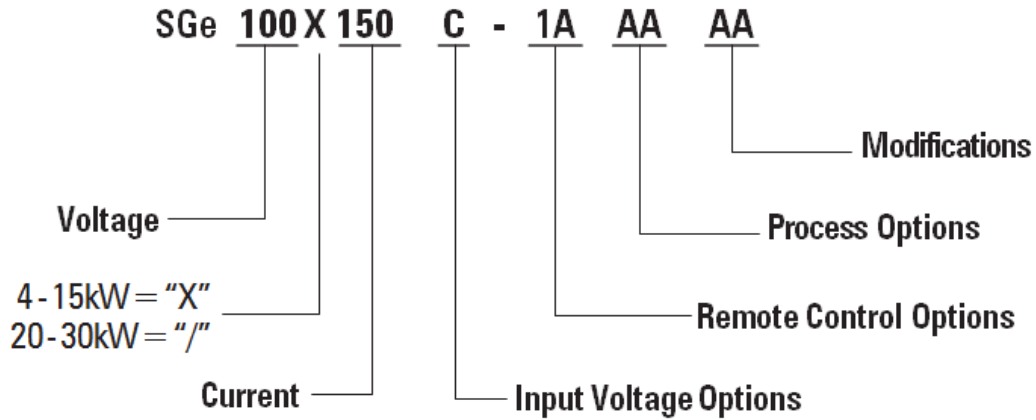

In the above example "100" represents 100V and "150" represents 150A. For units with voltage or current >=1000, the values are represented by the format "XKX", e.g. 1K2 = 1200 and 1K0 = 1000

Option	Description
Input Options	C: Input Voltage 208/230 VAC, 3-Phase D: Input Voltage 380/400 VAC, 3-Phase E: Input Voltage 440/480 VAC, 3-Phase
Remote Control Options	0A: No Option 1A: IEEE-488.2 + RS-232C 1C: Ethernet + RS-232C 1D: Isolated Analog Interface 1E: Shaft Locks 2A: Combined Options 1A + 1D 2C: Combined Options 1A + 1E 2G: Combined Options 1C + 1D 2H: Combined Options 1C + 1E 2J: Combined Options 1D + 1E 3C: Combined Options 1A + 1D + 1E 3G: Combined Options 1C + 1D + 1E
Process Options	AA: No option AB: Certificate of Calibration (includes test data)
Modifications	AJ: Front panel dust filter (3U models only) PF: Passive power factor correction (PFC) to 0.90, typical, for all models and all AC input ratings. BS: Includes All Option features of AJ + PF CV: 400 Hz AC input at 208 VAC for 6U units only and does not carry CE, CSA or UL certification; (standard in 3U models)

1.2 SPECIFICATIONS

The following subsections provide environmental, electrical, and physical characteristics for the SGe Series power supplies.

Note: Specifications are subject to change without notice.

Note: The SGe Series power supplies are intended for indoor use only. Refer to Section 2.3 for use/location requirements.

1.2.1 ENVIRONMENTAL CHARACTERISTICS

Parameter	Specification
Ambient Temperature	
Operating	0°C to 50°C
Storage	-25°C to 65°C
Cooling	Forced convection with internal, linearly-variable-speed fans; vents on front, sides and rear; units may be stacked without clearance above or below.
Humidity	95% maximum, non-condensing, 0°C to 50°C; 45°C maximum wet-bulb temperature.
Altitude	5,000 ft (1,524 m) operating at full rated output power, derate 10% of full power for every 1,000 ft (3,048 m) higher; non-operating to 40,000 ft (12,192m)
Agency Approvals	CE Compliant: Certified to UL/CSA 61010 and IEC/EN 61010-1 by a NRTL; LVD Categories: Installation Category II, Pollution Degree 2, Class II Equipment, for Indoor Use Only; EMC Directive, EN 61326:1998; Semi-F47 Compliant

1.2.2 ELECTRICAL CHARACTERISTICS

Note: Output voltage accuracy, regulation, and stability specifications are valid at the point where the remote sense leads are connected.

Parameter	Specification
Input Power	
Voltage	208/230 VAC $\pm 10\%$, allowed range 187-253 VAC; 380/400 VAC $\pm 10\%$, allowed range 342-440 VAC; 440/480 VAC $\pm 10\%$, allowed range 396-528 VAC
Frequency	47 Hz to 63 Hz; 400 Hz at 208 VAC for 3 U models; 400 Hz at 208 VAC for 6U models is an optional modification ("CV" in model number) and does not carry CE, UL or CSA markings
Configuration	3-phase, 3-wire plus ground; not phase rotation sensitive; neutral not used.

Parameter	Specification
Power Factor (at full rated load; 50/60 Hz); contact factory for power factor of specific models	
PFC with optional modification, "PF"	0.90, typical, for all AC input ratings; with passive power factor correction (PFC)
Non-PFC models: 40V-800V	0.75, typical, for 208/230 VAC input; 0.72, typical, for 380/400 VAC input; 0.69, typical, for 440/480 VAC input; power factor is not solely determined by power supply input characteristics, but is dependent on the level of DC output power and interaction with the source impedance of AC mains.
Efficiency	85%, typical, at full load, nominal AC line
Hold-Up Time	1/2 cycle, typical, for loss of all three phases (6.4 ms, typical for 800V/1000V models); 3 cycle, typical, for loss of one phase; sustained missing phase will result in shutdown of the output.
Rated Output Power	4-15 kW for 3U chassis for 10V-30V models; 5-15 kW for 3U chassis for 40V-1000V models; 20-30 kW for 6U chassis for 40V-600V models; maximum output power is the product of the rated output voltage and current; for specific values refer to Section 1.2.3.
Load Regulation (specified for $\pm 100\%$ rated load change, at nominal AC input voltage)	
Voltage	$\pm 0.05\%$, maximum, of rated output voltage for 10V- 30V models; $\pm 0.02\%$, maximum, of rated output voltage for 40V-1000V models
Current	$\pm 0.1\%$, maximum, of rated output current
Line Regulation (specified for $\pm 10\%$ change of nominal AC line voltage, at constant load)	
Voltage	$\pm 0.05\%$, maximum, of rated output voltage for 10V- 30V models; $\pm 0.01\%$, maximum, of rated output voltage for 40V-1000V models
Current	$\pm 0.05\%$, maximum, of rated output current
Temperature Coefficient	
Voltage	$\pm 0.02\%/^{\circ}\text{C}$, typical, of rated output voltage
Current	$\pm 0.03\%/^{\circ}\text{C}$, typical, of rated output current
Stability	$\pm 0.05\%$, typical, of rated output voltage or current, over 8 hrs at fixed line, load, and temperature, after 30 min warm-up
Output Voltage Ripple/Noise	Refer to Ripple/Noise specifications in tables of Section 1.2.3.
Load Transient Response	2 ms, typical, to recover within 0.75% of rated output voltage for load step change of 50% of rated output current
Output Voltage Rise Time (with rated load, resistive; current rise time same)	10 ms, maximum, from 10-90% of programming change from zero to rated output voltage for 10V-30V models; 100 ms, maximum, from 5-95% of programming change from zero to rated output voltage for 40V-1000V models; contact factory for values of specific models

Parameter	Specification
Output Voltage Fall Time (with rated load, resistive; current fall time same)	10 ms, maximum, from 90-10% of programming change from rated output voltage to zero for 10V-30V models; contact factory for values of specific models
Output Voltage Fall Time (with no load)	50 ms, maximum, from 90-10% of programming change from rated output voltage to zero for 10V-30V models; 1.5 s, typical, from 100% to 10% of programming change from rated output voltage to zero for 40V-1000V models; contact factory for values of specific models
Front Panel Meter	
Display Resolution	3.5 digit
Voltage Accuracy (to actual output)	±0.5%, maximum, of rated output voltage + 1 digit
Current Accuracy (to actual output)	±0.5%, maximum, of rated output current + 1 digit
Remote Sensing	
Connection	Voltage accuracy/regulation specifications apply at the point where the remote sense leads are connected.
Line Drop	1 V, maximum per line for 10V-20V models; 1.5 V, maximum per line for 30V model; 5%, maximum of rated output voltage per line for models, 40V to less than 160V; 2%, maximum of rated output voltage per line for models greater than or equal to 160V; greater level of line drop is allowed, but output voltage regulation specifications no longer apply.
Line Drop Effect on Output Voltage	Rated output voltage applies at the rear panel output terminals, and line drop voltage subtracts from the voltage available at the load terminals
Remote Analog Interface	
Programming Accuracy	
Voltage	±0.75%, maximum, of rated output voltage for 0-5 VDC range and 0-10 VDC range
Current	±1.0%, maximum, of rated output current for 0-5 VDC range, and ±1.2%, maximum, for 0-10 VDC range
Overvoltage Protection (OVP)	±3%, maximum, of rated output voltage
Readback Monitor Accuracy	
Voltage (of actual output value)	±1.0%, maximum, of rated output voltage
Current (of actual output value)	±1.0%, maximum, of rated output current
Resistive-Control Programming	
Voltage	0–5 kΩ for 0-100% of rated output voltage
Current	0–5 kΩ for 0-100% of rated output current

Parameter	Specification
Voltage-Control Programming	
Voltage	0–5 VDC or 0–10 VDC for 0-100% of rated output voltage
Current	0–5 VDC or 0–10 VDC for 0-100% of rated output current
Overvoltage Protection (OVP)	0.25–5.5 VDC for 5-110% of rated output voltage
Remote Control/Monitor Interface	On/Off control via contact closure, 6-120 VDC or 12-240 VAC, and TTL or CMOS gate; output voltage and current monitors; output voltage, current, and OVP programming; summary fault status
Output Isolation	
Output Float Voltage	
Negative Output Terminal	±300 V(PK), maximum, with respect to chassis ground; exceeding the limit will be detected as a fault by a protective supervisory monitor and shutdown of the output will be executed; this condition will be latched, requiring reset to resume normal operation.
Isolation of optional Isolated Analog Interface (J1) to output negative terminal	1000 V(PK), maximum; Isolated Analog Interface (J1 signals) are galvanically isolated from negative output terminal; operation of Isolated Analog Interface signals should be at SELV safety voltage conditions to chassis ground.
Reference of standard Non-Isolated Analog Interface (J1) to output negative terminal	The standard Non-Isolated Analog Interface (J1 signals) is connected to the negative output terminal and, therefore, is not isolated from the output.
Parallel Operation	
Parallel Group	Up to 5 units, of the same voltage rating, may be connected in parallel for additional output current; specifications apply as for single unit, with the exception that each additional paralleled unit will add 0.3% to the output current accuracy. Contact factory for applications requiring paralleling more than five units.
Series Operation	
Series Group	Up to 2 units, of the same current rating, may be connected in series for additional output voltage; see restrictions in Output Isolation section.

1.2.3 SGe SERIES VOLTAGE AND CURRENT SPECIFICATIONS

The following tables present the specifications for rated voltage and current, and ripple/noise for the 10V-1000V models.

Rated Voltage, VDC	Rated Current, ADC						Ripple/ Noise** RMS, mV	Ripple/ Noise* PK-PK, mV
	4 kW	5 kW	8 kW	10 kW	12 kW	15 kW		
0-10 ^{††}	0-400	N/A	0-800	N/A	0-1200	N/A	20	60
0-15 ^{††}	0-267	N/A	0-534	N/A	0-801	N/A	20	60
0-20 ^{††}	N/A	0-250	N/A	0-500	N/A	0-750	20	60
0-30 ^{††}	N/A	0-167	N/A	0-334	N/A	0-501	20	60

Rated Voltage, VDC	Rated Current, ADC						Ripple/ Noise** RMS, mV	Ripple/ Noise* PK-PK, mV
	5 kW	10 kW	15 kW	20 kW	25 kW	30 kW		
0-40	0-125	0-250	0-375	0-500 [†]	0-625 [†]	0-750 [†]	20	75
0-50	0-100	0-200	0-300	0-400 [†]	0-500 [†]	0-600 [†]	20	75
0-60	0-83	0-167	0-250	0-333	0-417	0-500	20	75
0-80	0-63	0-125	0-188	0-250	0-313	0-375	25	100
0-100	0-50	0-100	0-150	0-200	0-250	0-300	25	100
0-160	0-31	0-63	0-94	0-125	0-156	0-188	25	150
0-200	0-25	0-50	0-75	0-100	0-125	0-150	25	175
0-250	0-20	0-40	0-60	0-80	0-100	0-120	25	200
0-300	0-17	0-33	0-50	0-67	0-83	0-100	60	200
0-330	0-15	0-30	0-45	0-61	0-76	0-91	60	200
0-400	0-12	0-25	0-38	0-50	0-63A	0-75	60	300
0-500	0-10	0-20	0-30	0-40	0-50	0-60	60	350
0-600	0-8	0-17	0-25	0-33	0-42	0-50	60	350
0-800	0-6.2	0-12.5	0-18.7	0-25 [†]	0-31.2 [†]	0-37.5 [†]	80	650
0-1000	0-5	0-10	0-15	0-20 [†]	0-25 [†]	0-30 [†]	100	750

* PK-PK ripple/noise, over 20 Hz to 20 MHz bandwidth, is measured across a 1 μ F capacitor at the end of a 6' load cable with the supply operating at full load and nominal AC line voltage.

** RMS ripple/noise, over 20 Hz to 300 kHz bandwidth, is measured directly across the output terminals with the supply operating at full load and nominal AC input line voltage.

† Power level not available in 6U models, but could be produced with paralleled 3U units; up to 75 kW could be produced by paralleling up to five units. Note that paralleling will increase ripple/noise.

†† Models from 10V-30V are not available in 6U chassis.

1.2.4 PHYSICAL CHARACTERISTICS

Dimensions	3U Models, 10V-30V	3U Models, 40V-1000V	6U Models, 60V-600V
Width	19.00 in (48.26 cm)	19.00 in (48.26 cm)	19.00 in (48.26 cm)
Depth	From inner surface of front panel to maximum protrusion of protective covers at rear panel; refer to installation drawings for chassis dimensions.		
	28.09 in (71.35 cm)	25.46 in (64.67 cm)	27.18 in (69.04 cm)
Height	5.25 in (13.34 cm)	5.25 in (13.34 cm)	10.5 in (26.67 cm)
Weight (nominal in shipping box)	≤ 65 lb (29 kg), (4 kW, 10V, 15V) ≤ 65 lb (29 kg), (5 kW, 20V, 30V) ≤ 85 lb (39 kg), (8 kW, 10V, 15V) ≤ 85 lb (39 kg), (10 kW, 20V, 30V) ≤ 110 lb (50 kg), (12 kW, 10V, 15V) ≤ 110 lb (50 kg), (15 kW, 20V, 30V)	≤ 60 lb (27 kg), (5 kW) ≤ 75 lb (34 kg), (10 kW) ≤ 90 lb (41 kg), (15 kW)	≤ 140 lb (63 kg), (20 kW) ≤ 155 lb (70 kg), (25 kW) ≤ 170 lb (77 kg), (30 kW)
Shipping Weight	Units ≤ 75 lb ship w/o a pallet for single unit orders. For two units or more they will be palletized. Two to four units will be on a 40x25 inch pallet weighing 14 pounds. More than four and no greater than eight will be stacked on a 36x48 pallet which weighs 22 pounds. All other units will be shipped palletized from one unit to two units high on a pallet. One and two units will ship on a 40x25 pallet weighing 14 pounds. Three and four units will ship on a 36x48 pallet weighing 22 pounds.		

SECTION 2 INSTALLATION

2.1 INSPECTION

Inspect the shipping carton for possible damage before unpacking the unit. Carefully unpack the equipment. Save all packing materials until inspection is complete. Verify that all items listed on the packing slips have been received. Visually inspect all exterior surfaces for broken knobs, connectors, or meters. Inspect for dented or damaged exterior surfaces. External damage may be an indication of internal damage. If any damage is evident, immediately contact the carrier that delivered the unit and submit a damage report. Failure to do so could invalidate future claims. Direct repair issues to Customer Service at www.programmablepower.com/support/support.htm and RMA requests at www.programmablepower.com/support/RMA.htm.

2.2 CONTENTS OF SHIPMENT

Depending on the model, configuration, and options available for your SGe Series power supply, the ship kit may include additional parts and accessories.

Minimum items included in the ship kit:

- AMETEK manuals CD-ROM (P/N M550008-01) containing the SGe Series DC Power Supplies Operation Manual (this manual, P/N M551443-01) and the SG manual for the digital interface options, IEEE 488.2/RS232 and Ethernet Programming Manual (P/N M550129-03). The latest manuals and software can be found on the website at www.programmablepower.com
- Sense mating connector:
10V-800V models, (Molex P/N 39-01-4031) with loose contacts (Molex P/N 39-00-0182).
1000V model, (Molex P/N 39-01-4041) with loose contacts (Molex P/N 39-01-0182).
- J1 mating connector (Cinch P/N DB25P or equivalent); shipped attached to rear panel connector, J1.

- Backshell for J1 (DB25) mating connector (Cinch P/N DCH-B-001, or equivalent).
- Hardware for input/output terminal power connections:
 - 3U, 4-15 kW, 10V-30V models: 1/2-13UNC-2B x 1.25" long, 4 ea, with nut, washer, and lockwasher;
 - 3U, 5-15 kW, 40V-600V models: 3/8-16UNC-2B x 1.0", 2 ea, with nut, washer, and lockwasher;
 - 3U, 5-15 kW, 800V and 1000V models have studs, 1/4-20UNC-2B, 2 ea, with nut, washer, and lockwasher installed on rear panel;
 - 6U, 20-30 kW: 3/8-16UNC-2B x 0.875", 2 ea, with nut and lockwasher, for DC output; 1/4-20UNC-2B, 4 ea, with Keps nut for AC input.
- Front panel rack fastener, black screw:
 - 3U, 10V -1000V models: 10-32UNC-2B x 0.5", 4 ea;
 - 6U, 20-30 kW: 10-32UNC-2B x 0.5", 8 ea.

Note: If any of these parts are missing, contact Customer Service at Sorensen.ppd@ametek.

Optional accessories:

890-453-03: Paralleling Cable (for up to 5 units, requires one cable per unit placed in parallel)

K550212-01: 3U Rack Slides (for 4 kW to 15 kW models)



K550213-01: 6U Rack Slides (for 20 kW to 30 kW models)

5550568-01: Front panel dust filter - field installation kit - 3U models only

5551082-01: Optional AC input cover kit - 3U models only

2.3 LOCATION AND MOUNTING

Refer to Sections 2.7 for dimensional and installation drawings

	<p>WARNING! This unit is intended for installation in a protected environment. Exposure to conductive contaminants or corrosive compounds/gases that could be ingested into the chassis could result in internal damage. To reduce the risk of fire or electrical shock, install the SGe Series unit in a temperature and humidity controlled indoor area.</p>
	<p>CAUTION! The unit should be provided with proper ventilation. The front, rear and both sides of the unit should be free of obstructions. To ensure proper airflow, a minimum 4" clearance from the rear air outlet is required. The unit should not be operated in an ambient temperature greater than 50°C.</p>
	<p>CAUTION! No user serviceable parts inside; service to be performed by qualified personnel only.</p>

**BURN HAZARD!**

Hot Surface Warning. Allow unit to cool before servicing.

2.3.1 RACK MOUNTING

The SGe Series models are designed for mounting in a standard 19-inch equipment rack compliant to EIA-310. If additional instrumentation is mounted in the rack, no additional clearance is required above or below the SGe Series units.

Support the SGe Series unit using appropriate L-brackets or rack mount slides; suggested slide kits are listed as follows:

Rack Mount Slide Kit (Option):

3U models, 4–15 kW: AMETEK part number K550212-01

6U models, 20–30 kW: AMETEK part number K550213-01

2.3.2 K550212-01 ASSEMBLY STEPS (OPTION KIT FOR 3U MODELS)

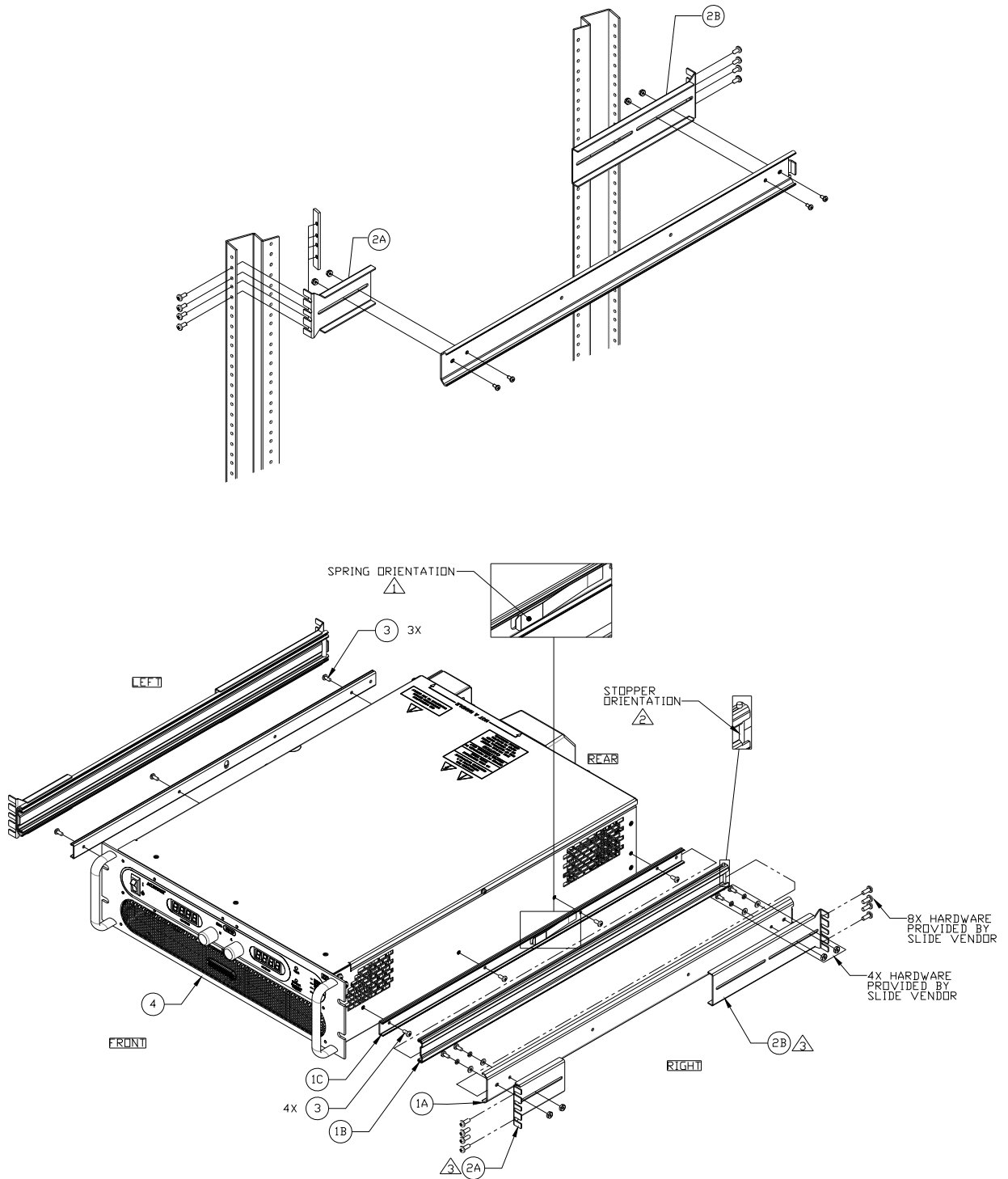

Figure 2-1. Rack Mount Assembly for 3U Models

**WARNING!**

A minimum two-person lift is required for the 3U SGe Series power supply, which weighs up to 110 lbs (50 kg) depending on the model.

Refer to Figure 2-1 for 3U rack mount assembly drawing for the following instructions:

1. Install the slide sections, (1C), on both sides of the power supply chassis with screws (three on left side and four on right side). Ensure that the latch spring orientation is as shown in Note (1).
2. Install the brackets, (2A) and (2B), to the stationary slide sections, (1A), with the hardware provided by the slide supplier as shown in Note (3). Ensure that stopper orientation of slide sections, (1B), is as shown in Note (2). Adjust the location of the mounting brackets as required for the particular type of cabinet vertical rails utilized.
3. Mount the stationary slide sections, (1A), (with brackets already installed) into the cabinet using appropriate hardware (e.g. bar nuts, cage nuts, clip nuts), while ensuring that they are level front to back and left to right of the cabinet rails.
4. Insert power supply chassis with slide sections, (1C), into slide sections, (1B).
5. Secure the front panel of the power supply chassis to the cabinet rack rails using the screws provided in the ship kit.

2.3.3 K550213-01 ASSEMBLY STEPS (OPTION KIT FOR 6U MODELS)

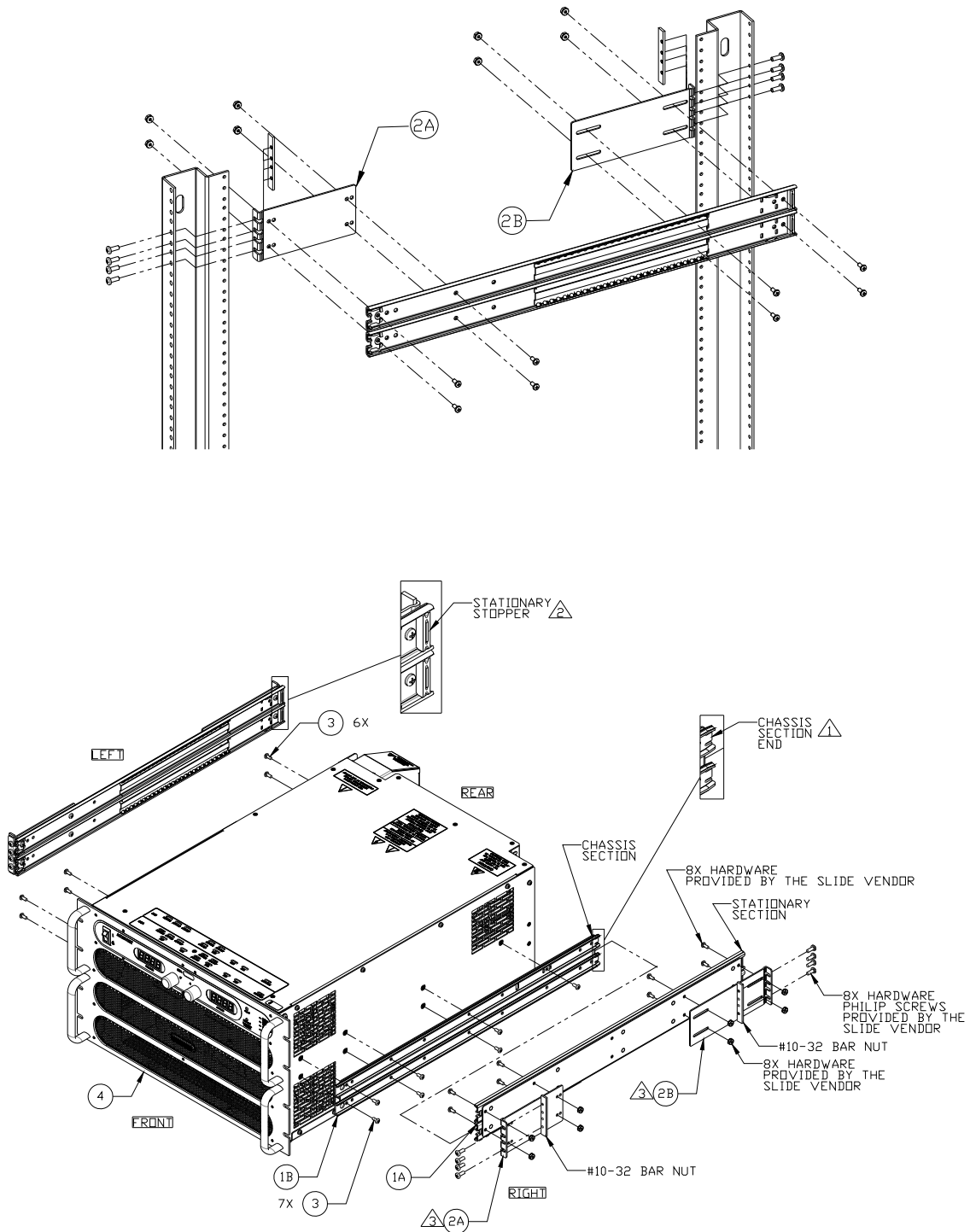





Figure 2-2. Rack Mount Assembly for 6U Models

**WARNING!**

A minimum three-person lift is required for the 6U SGe Series power supply, which weighs up to 170 lb (77kg) depending on the model.

Refer to Figure 2-2 for 6U rack mount assembly drawing for the following instructions:

1. Install the slide sections, (1B), on both sides of the power supply chassis with screws (six on left side and seven on right side). Ensure that the section end orientation is as shown in Note .
2. Install the brackets, (2A) and (2B), to the stationary slide sections, (1A), with the hardware provided by the slide supplier as shown in Note . Ensure that the stopper orientation is as shown in Note . Adjust the location of the mounting brackets as required for the particular type of cabinet vertical rails utilized.
3. Mount the stationary slide sections, (1A), (with brackets already installed) into the cabinet using appropriate hardware (e.g. bar nuts, cage nuts, clip nuts), while ensuring that they are level front to back and left to right of the cabinet rails.
4. Insert power supply chassis with slide sections, (1B), into slide sections, (1A).
5. Secure the front panel of the power supply chassis to the cabinet rack rails using the screws provided in the ship kit.

2.3.4 CHASSIS REMOVAL FROM RACK

**WARNING!**

A minimum two-person lift is required for the 3U SGe Series power supply, which weighs up to 110 lb (50 kg) depending on the model.







A minimum three-person lift is required for the 6U SGe Series unit, which weighs up to 170 lb (77 kg) depending on the model.

The slides have a front disconnect feature and lock at full extension. To disconnect and remove the chassis from the rack, depress the flat steel spring (located on the slides) inward, and pull the chassis forward. To return the chassis back into the rack from full extension, depress the flat steel spring (located on the slides) inward, and push the chassis back.

When the chassis is at full extension, the flat springs are located behind the front rack rails. Retract the springs with a flat blade screwdriver or similar device to release from lock-out or to remove the chassis from the rack.

2.4 INPUT/OUTPUT CONNECTIONS

Refer to Table 2–1 for AC input current requirements and Section 1.2.3 for output current specifications. Table 2–3 provides information on the external input and output connections for the SGe Series models. Table 2–4 provides input connections descriptions, and Table 2–5 provides output connection descriptions. Refer to Table 2–6 for recommendations on input/output lugs, and Table 2–7 on crimping and extraction tools for the sense connector pins.

	<p>WARNING! High voltage present at rear panel! Risk of electrical shock. Do not remove protective covers on AC input or DC output. Refer to qualified service personnel.</p>
	<p>WARNING! The input and output voltages at the rear panel of the unit might be HAZARDOUS LIVE. When rack-mounting or panel-mounting the unit, suitable safeguards must be taken by the installer to ensure that HAZARDOUS LIVE voltages are not OPERATOR accessible. OPERATOR access should only be to the front panel of the unit.</p>
	<p>WARNING! A safety disconnect device for the AC mains input must be installed so that it is readily accessible to the user.</p>
	<p>WARNING! A properly sized input overcurrent protection device must be installed at the AC mains input, either a circuit breaker or fuse having a rating of 25% over the maximum AC input line currents listed in Table 2–1.</p>
	<p>WARNING! To prevent an electrical shock hazard, a safety ground wire must be connected from the safety ground stud on the rear panel to the AC mains ground.</p>
	<p>CAUTION! Under no condition should the negative output terminal exceed 300 V to earth ground. Floating the negative output terminal subjects the internal control circuitry of the power supply to the same potential as present at the negative output terminal. In a unit with the standard Non-Isolated Analog Interface, the signals of control connector, J1, would float at the same potential as the negative output terminal. Damage might occur if the signals of the Non-Isolated Analog control connector are connected to an external ground referenced device, due to unintentional ground loop currents that this connection could generate. To correct ground loop problems, it is advised to use the optional Isolated Analog Interface in order to isolate the external signals from the internal control circuitry of the supply. Refer to Section 1.2.2 of the specifications for additional information.</p>

Model Ratings			Input Line Current, A(RMS)					
Voltage Model	AC Input Option Code	Input Voltage, VAC	5 kW	10 kW	15 kW	20 kW	25 kW	30 kW
40V-1000V	C	208/230	20	39	59	79	98	118
	D	380/400	11	22	32	43	54	65
	E	440/480	9	19	28	37	47	56
			4 kW	8 kW	12 kW	5 kW	10 kW	15 kW
10V-15V	C	208/230	16	32	47	N/A	N/A	N/A
	D	380/400	9	17	26	N/A	N/A	N/A
	E	440/480	7	15	22	N/A	N/A	N/A
20V-30V	C	208/230	N/A	N/A	N/A	20	39	59
	D	380/400	N/A	N/A	N/A	11	22	32
	E	440/480	N/A	N/A	N/A	9	19	28

Table 2–1. Maximum AC Current Ratings, PFC Models

Model Ratings			Input Line Current, A(RMS)*					
Voltage Model	AC Input Option Code	Input Voltage, VAC	5 kW	10 kW	15 kW	20 kW	25 kW	30 kW
40V-800V	C	208/230	24	47	71	95	118	142
	D	380/400	13	27	40	54	67	81
	E	440/480	12	24	36	49	61	73

* AC input current varies depending on actual power factor; refer to specifications section on power factor

Table 2–2. Maximum AC Current Ratings, Non-PFC Models

Connector	Function	Connection
L1 – AC, L2 – AC, L3 – AC; Chassis - GND	AC input power; see Table 2–4	AC mains 3-phase input
Pos. Bus Bar, Neg. Bus Bar	DC output power; see Table 2–5	User load
Analog Interface Connector (J1)	Control interface; see Table 3–5	User controller
Remote Sense Connector	Remote voltage sensing; see Section 3.9	Output load
Parallel In/Out	Parallel operation; see Section 3.11	Master/Slave units

Table 2–3. Input/Output Connectors

Power Supply Type	Connection	Connection Description
4 kW to 15 kW, 3U	AC Input	Feed-Through terminal block with compression terminals
20 kW to 30 kW, 6U	AC Input	Bus Bar with holes for 1/4–20 bolts
All 3U and 6U	Chassis Safety Ground	1/4-20 stud

Table 2–4. Input Terminal Connections



CAUTION!

To prevent damage to the AC input connector of the 3U units, follow torque specifications, and, if a wire ferrule is used, ensure that it is properly sized and that it has been crimped with the appropriate ferrule crimping tool.

AC Input Connector for 3U Models

- Recommended torque for the AC input connector screws: 17.7 in-lb to 20.4 in-lb (2 Nm to 2.3 Nm).
- Wire ferrules are recommended, properly sized to match the wire gauge; use appropriate crimp tool for the ferrule size.
- Wire insulation should be stripped to 5/8", maximum.
- For more information on the AC input connector, refer to the manufacturer (Phoenix Contact) part number HDFKV 16 at their website, www.phoenixcontact.com.

Power Supply Type	Connection Description
4 kW to 15 kW, 10V-30V models	Bus bars with two holes for 1/2" bolts on each terminal (POS. and NEG.)
5 kW to 15 kW, 40V-1000V models	40V-600V models: bus bars with single holes for 3/8" bolts on each terminal (POS. and NEG.) 800V and 1000V models: 1/4-20 studs for each terminal (POS. and NEG.)
20 kW to 30 kW	Bus bars with single holes for 3/8" bolts for each terminal (POS. and NEG.)

Table 2–5. Output Terminal Connections

Manufacturer	Low Current	High Current
Panduit	P, PV, or PN series, or equivalent	Standard stranded wire: LCA Series, or equivalent Flexible stranded wire: LCAX Series, or equivalent
<i>Note: Contact lug manufacturer for recommended crimping tool.</i>		

Table 2–6. Recommended Lugs

Tool	Manufacturer	Manufacturer P/N
Crimping	Molex	11-01-0197
Extracting	Molex	11-03-0044

Table 2–7. Recommended Sense Connector Tools

2.5 WIRE SELECTION

Care must be taken to properly size all conductors for the input and output of the power supply. This section provides guidance in the selection of wire size.



CAUTION!

Cables with Class B or C stranding should be used. Fine-stranded (flexible) cables should not be used unless crimp-on lugs or ferrules are used that are approved for fine-stranded cables.

2.5.1 WIRE SIZE

The tables below will assist in determining the appropriate wire size for both the input and output connections. Table 2–8 gives *minimum* recommended wire size; these recommendations are for copper wire only. This table is derived from the National Electrical Code, and is for reference only. Local laws and conditions may have different requirements; refer to the National Electrical Code for guidelines.

Size	Temperature Rating of Copper Conductor			
	60°C	75°C	85°C	90°C
AWG	Types: RUW, T, TW, UF	Types: FEPW, RHW, RH, RUH, THW, THWN, XHHW, USE, ZW	Types: V, MI	Types: TA, TBS, SA, AVB, SIS, FEP, FEPB, RHH, THHN, XHHW
	Current Rating, A(RMS)			
14	20	20	25	25
12	25	25	30	30
10	30	35	40	40
8	40	50	55	55
6	55	65	70	75
4	70	85	95	95
3	85	100	110	110
2	95	115	125	130
1	110	130	145	150
0	125	150	165	170
00	145	175	190	195
000	165	200	215	225
0000	195	230	250	260

Table 2–8. Minimum Wire Size

When determining the optimum cable specification for your power applications, the same engineering rules apply whether at input or output of an electrical device. Thus, this guide applies equally to the AC input cable and DC output cable for this power supply and application loads.

Power cables must be able to safely carry maximum load current without overheating or causing insulation degradation. It is important to power supply performance to minimize IR (voltage drop) loss within the cable. These losses have a direct effect on the quality of power delivered to and from the power supply and corresponding loads.

When specifying wire gauge, consider derating due to the operating temperature at the wire location. Wire gauge current capability and insulation performance drops with the increased temperature developed within a cable bundle and with increased environmental temperature. Thus, short cables with generously derated gauge and insulation properties are recommended for power source applications.

Be careful when using published commercial utility wiring codes. These codes are designed for the internal wiring of homes and buildings and accommodate the safety factors of wiring loss, heat, breakdown insulation, aging, etc. However, these codes consider that up to 5% voltage drop is acceptable. Such a loss directly detracts from the performance specifications of this SG power supply. Also, consider how the wiring codes apply to bundles of wire within a cable arrangement.

In high performance applications requiring high inrush/ transient currents, additional consideration is required. The cable wire gauge must accommodate peak currents developed at peak voltages, which might be up to ten times the average current values. An underrated wire gauge adds losses, which alter the inrush characteristics of the application and thus the expected performance.

Table 2–9 presents wire resistance and resulting cable voltage drop at maximum rated current, with the wire at 20°C. Copper wire has a temperature coefficient of $\alpha = 0.00393\Omega/^{\circ}\text{C}$ at $t_1 = 20^{\circ}\text{C}$, so that at an elevated temperature, t_2 , the resistance would be $R_2 = R_1 (1 + \alpha (t_2 - t_1))$.

Column 1	Column 2	Column 3	Column 4
Size, AWG	A(RMS)	Ohms/100 Ft (One Way)	Voltage Drop/100 Ft (Column 2 x Column 3)
14	20	0.253	5.06
12	25	0.156	3.90
10	30	0.999	3.00
8	40	0.063	2.52
6	55	0.040	2.20
4	70	0.025	1.75
3	85	0.020	1.70
2	95	0.016	1.52
1	110	0.012	1.32
0	125	0.010	1.25
00	145	0.008	1.16
000	165	0.006	0.99
0000	195	0.005	0.98

Table 2–9. Wire Resistance and Voltage Drop, 20°C

2.6 LOAD CONSIDERATIONS

This section provides guidelines for incorporating protective diode networks at the output of the power supply to prevent damage while driving inductive loads or loads having stored energy that could be circulated back to the power supply.

2.6.1 INDUCTIVE AND STORED-ENERGY LOADS

To prevent damage to the power supply from inductive voltage kickback, connect an anti-parallel diode (rated at greater than the supply's output voltage and current) across the output: Connect the cathode to the positive output and the anode to return.

Where positive load transients, such as back EMF from a motor might occur, or stored energy is present such as a battery, a second blocking diode in series with the output is recommended to protect the power supply.

BLOCKING AND ANTI-PARALLEL DIODES

Ensure that the chosen components are suitably rated for the particular inductance and energy to be dissipated. The Peak Reverse Voltage ratings should be a minimum of 2 times the Power Supply maximum output voltage. The Continuous Forward Current ratings should be a minimum of 1.5 times the power supply maximum output current. A heatsink may be required to dissipate the power caused by flow of current.

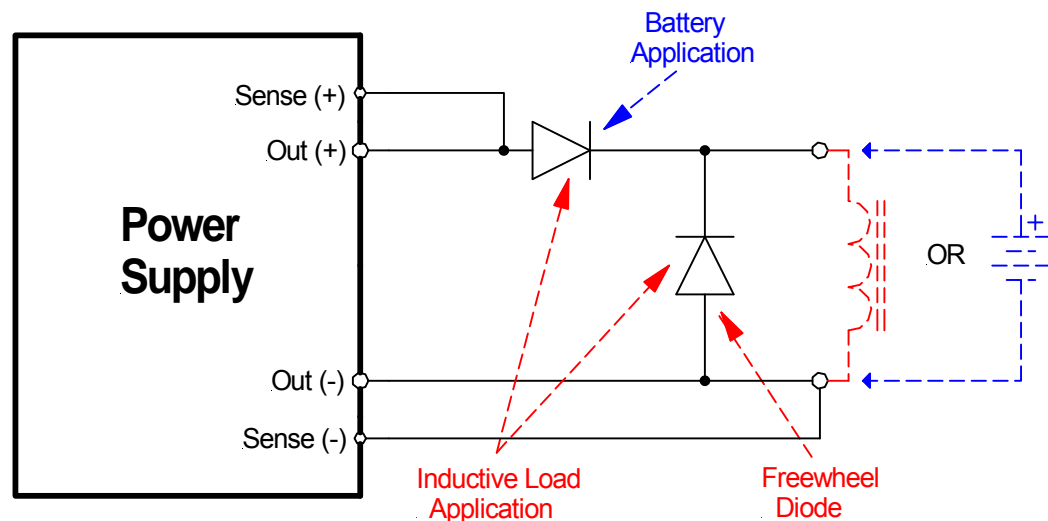

Figure 2-3. Diode Connection

2.7 OUTLINE AND INSTALLATION DRAWINGS

Figure 2-4 through Figure 2-7 show the outlines and overall dimensions for installation of the 3U and 6U models of the SGe Series power supplies.

Figure 2-8 through Figure 2-16 show locations of rear panel connectors.

Figure 2-17 shows protective covers for the AC input and DC output of the 3U 10V-30V models.

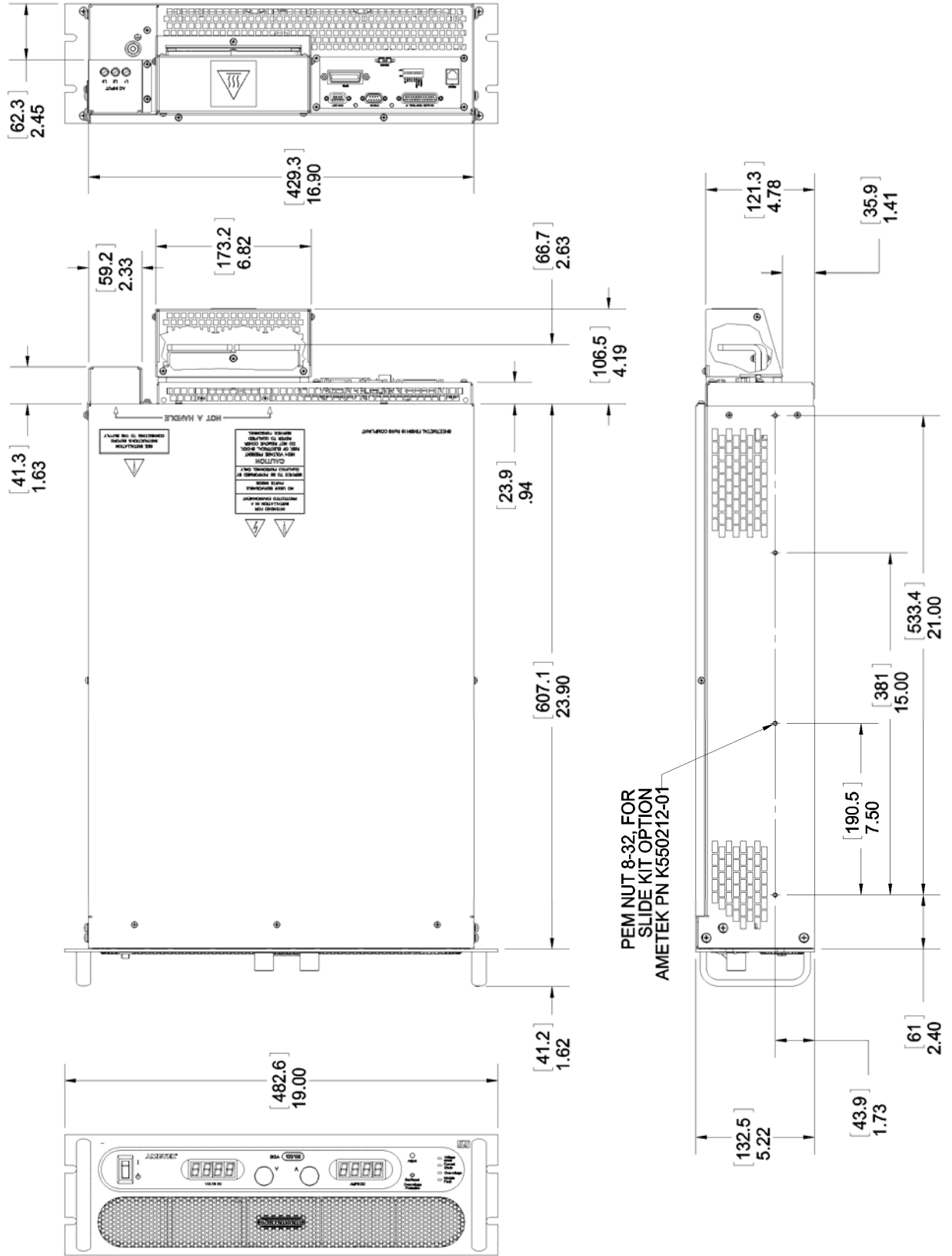

Figure 2-4. Installation Drawing, 3U Models 10V-30V

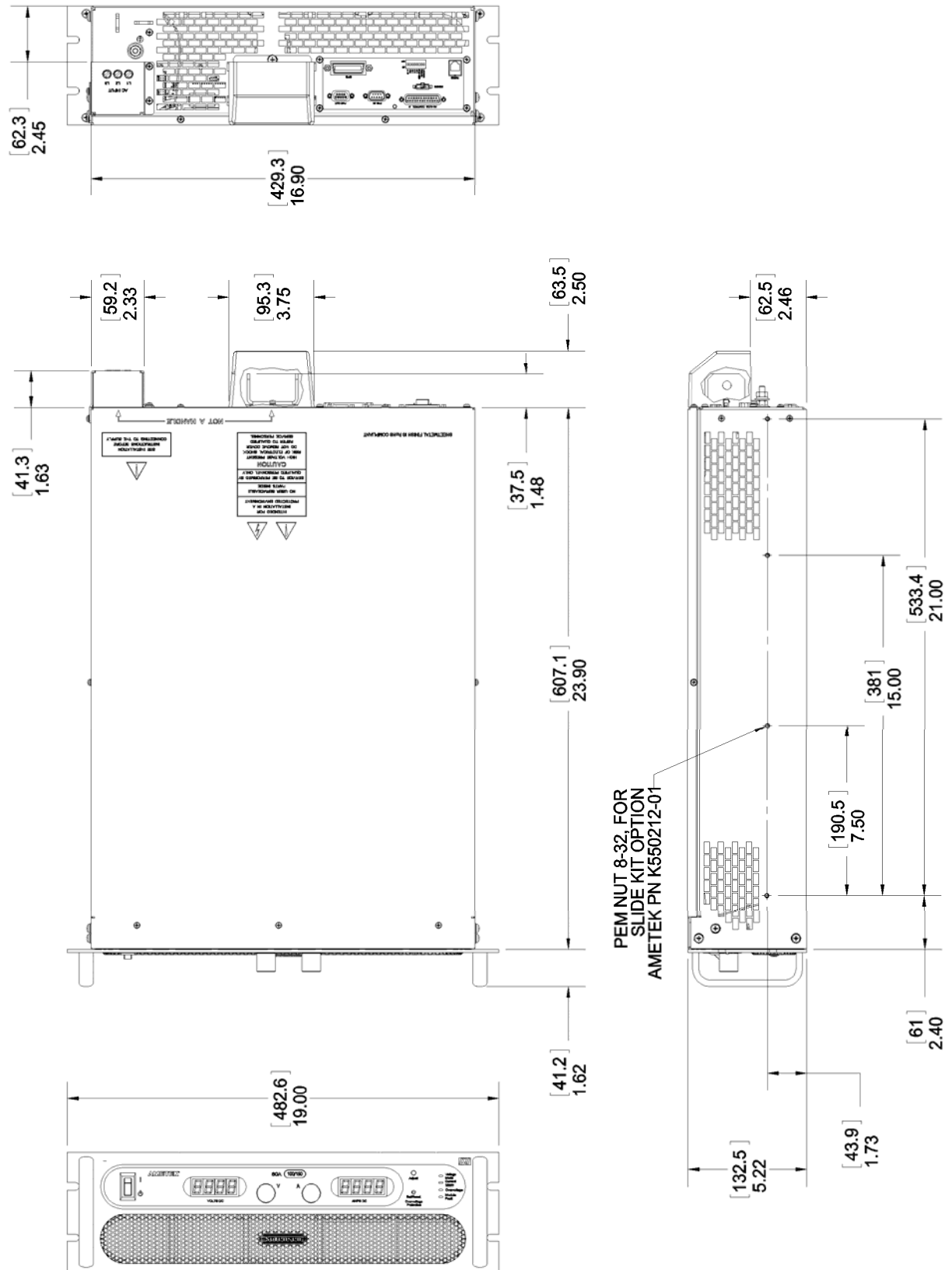

Figure 2-5. Installation Drawing, 3U Models 40V-600V

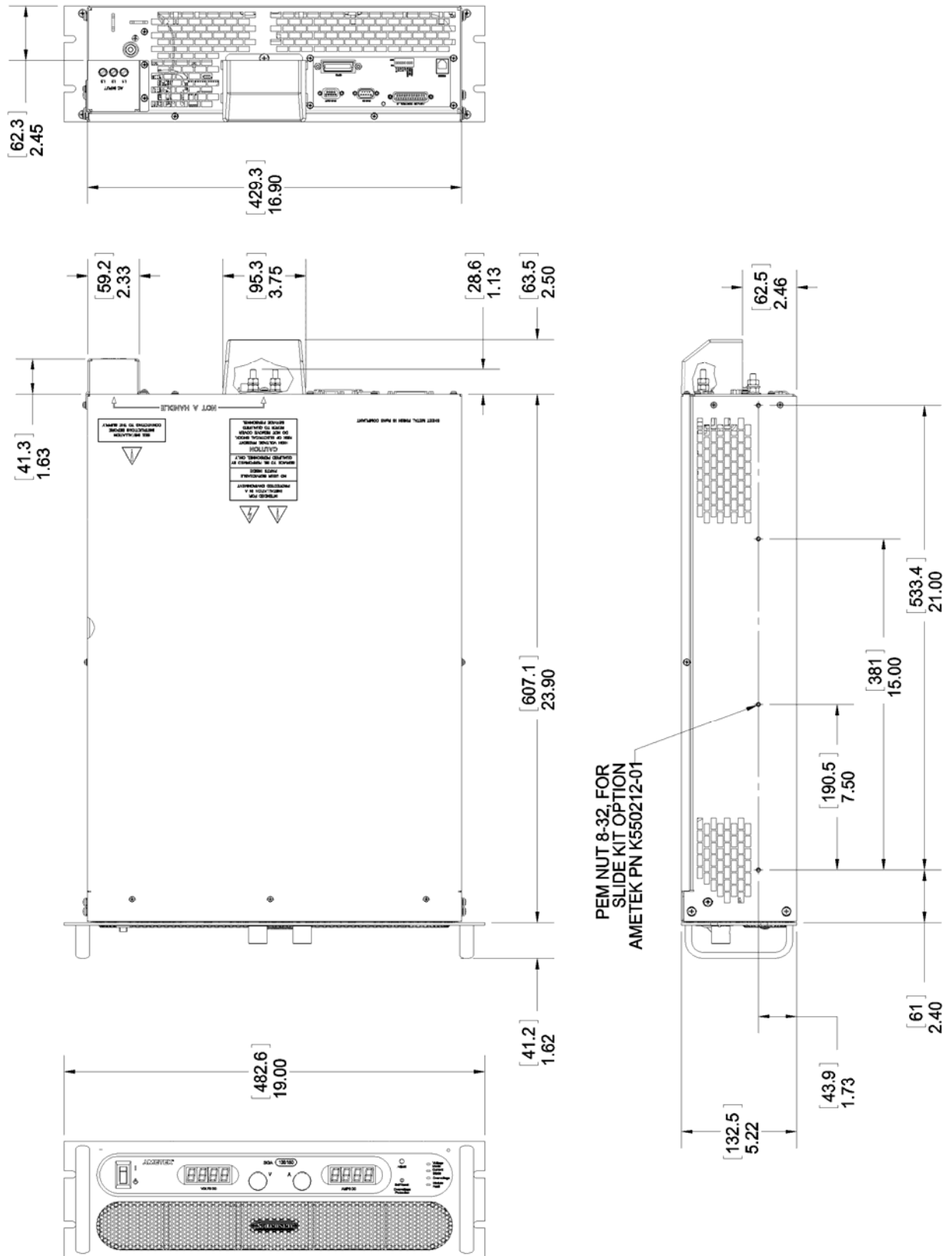

Figure 2-6. Installation Drawing, 3U Models 800V-1000V

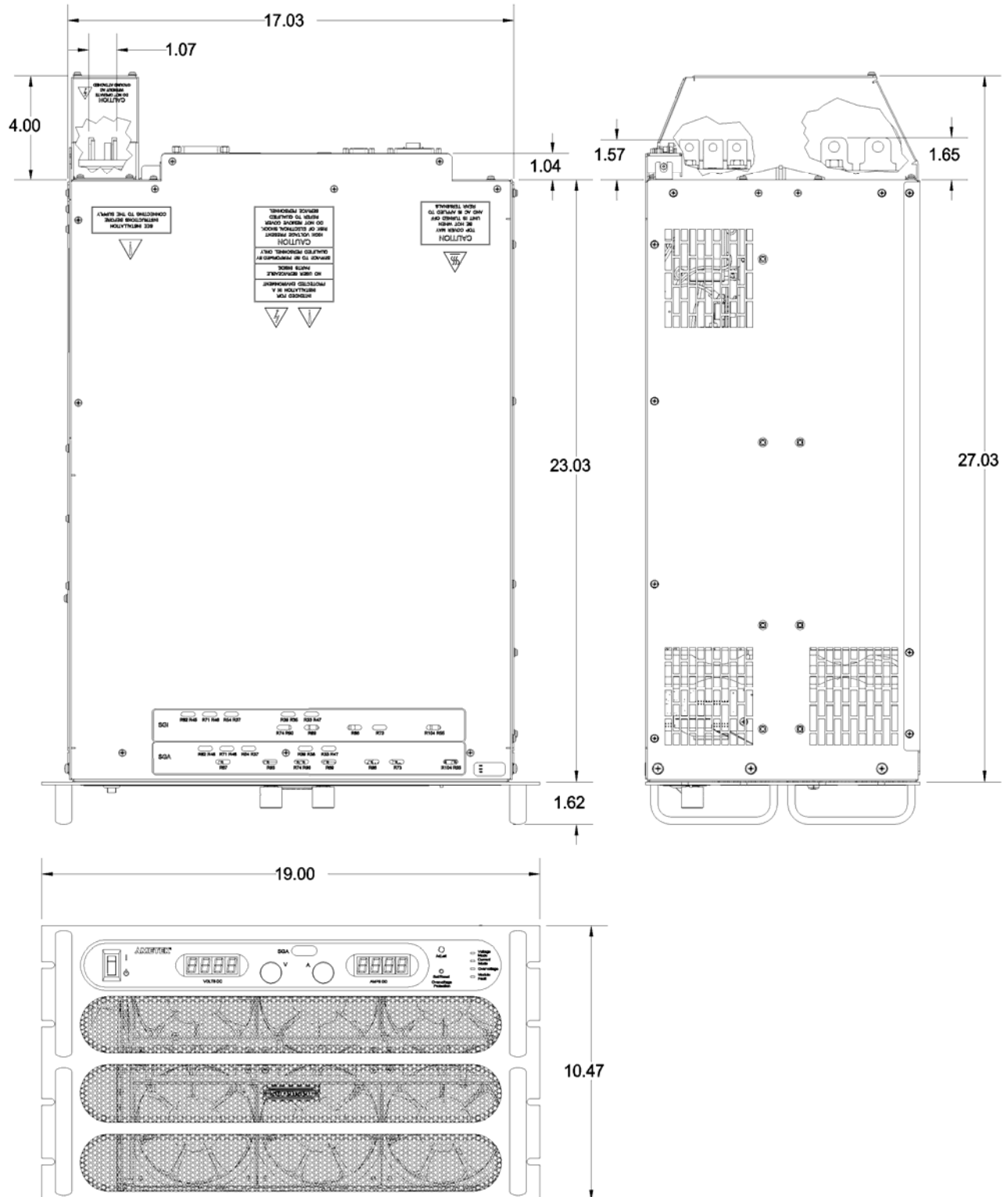

Figure 2-7. Installation Drawing, 6U Models 20 kW to 30 kW

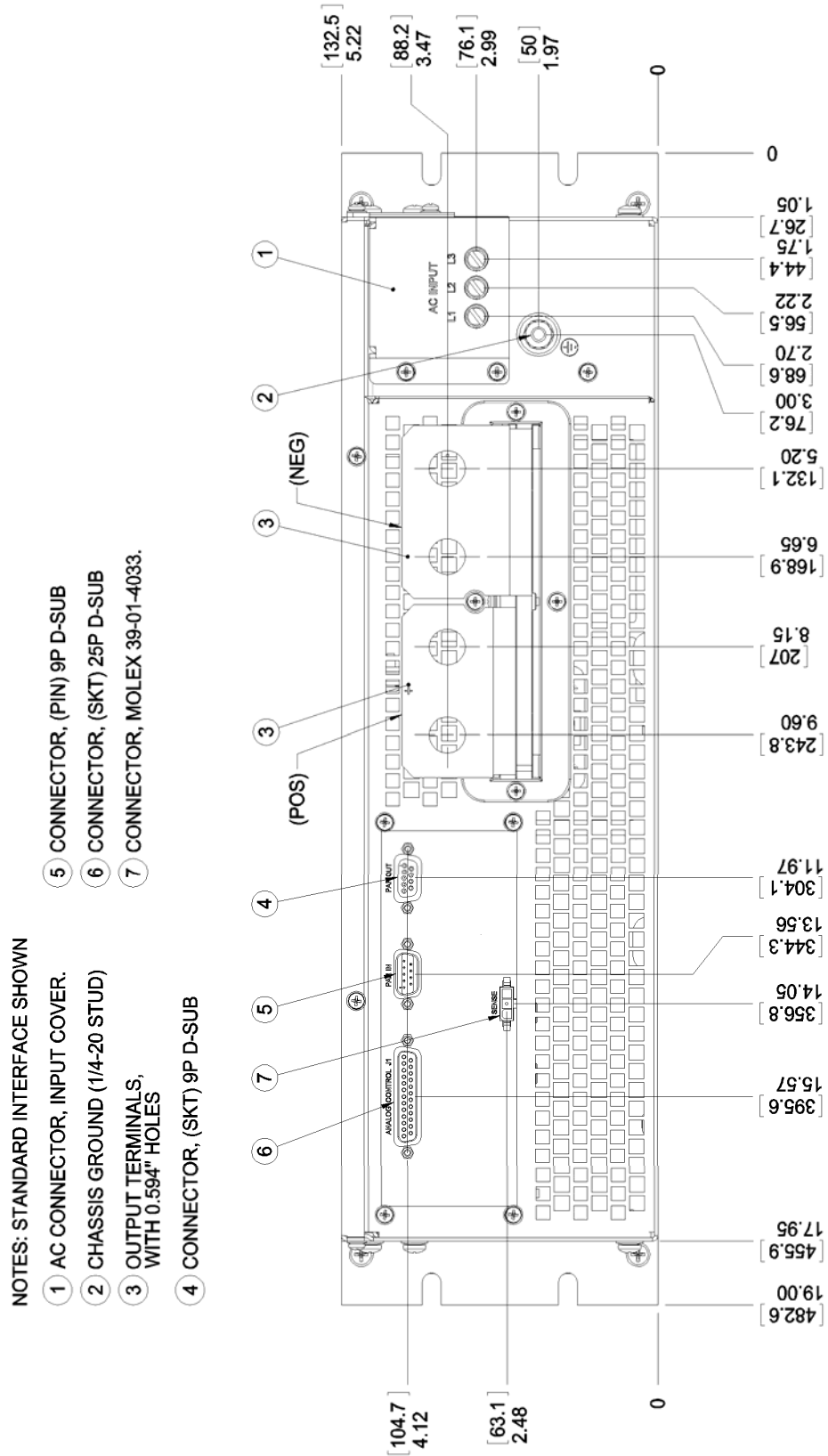

Figure 2-8. Rear Panel, Standard, 3U Models 10V-30V

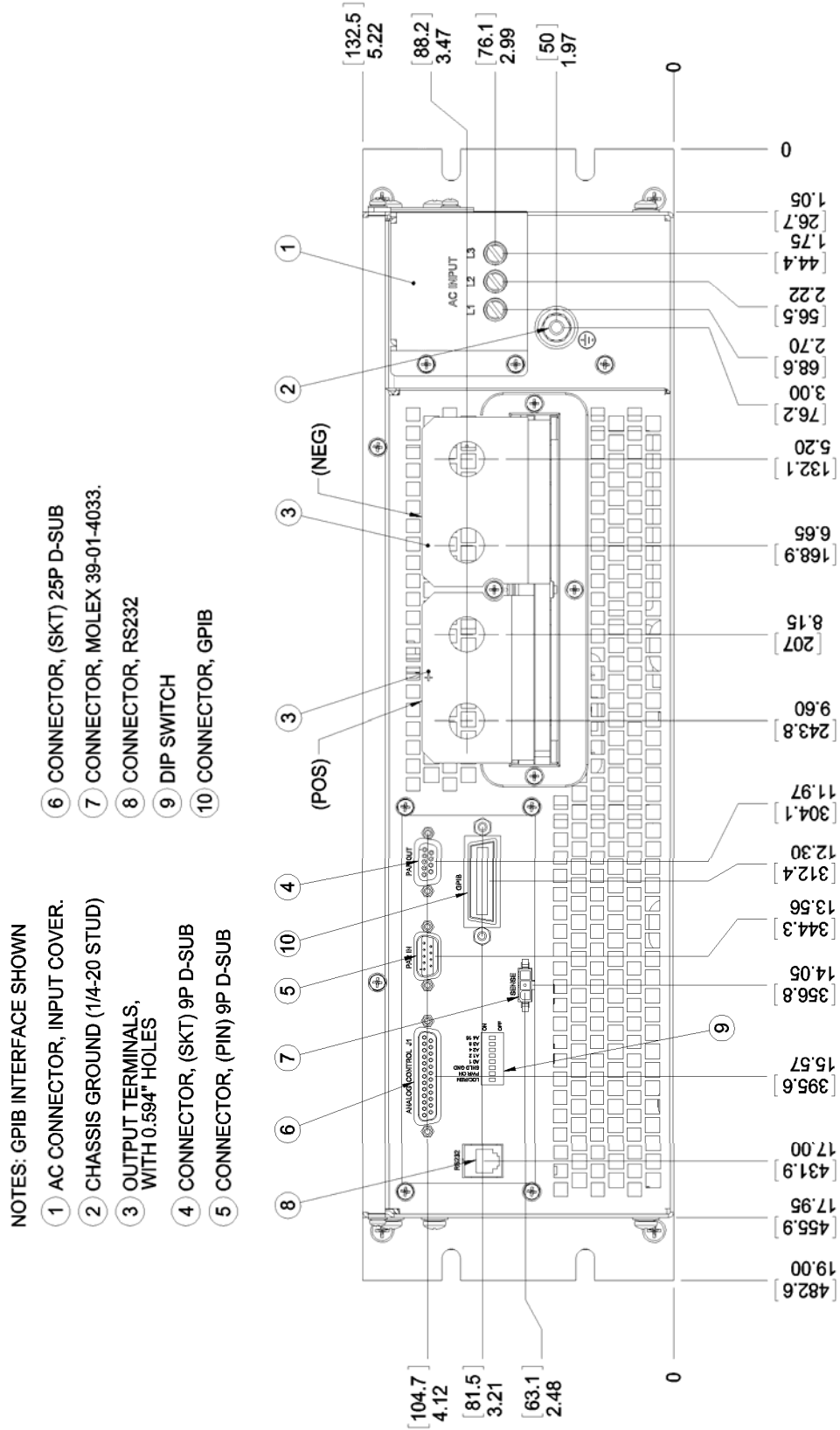

Figure 2-9. Rear Panel, GPIB Option, 3U Models 10V-30V

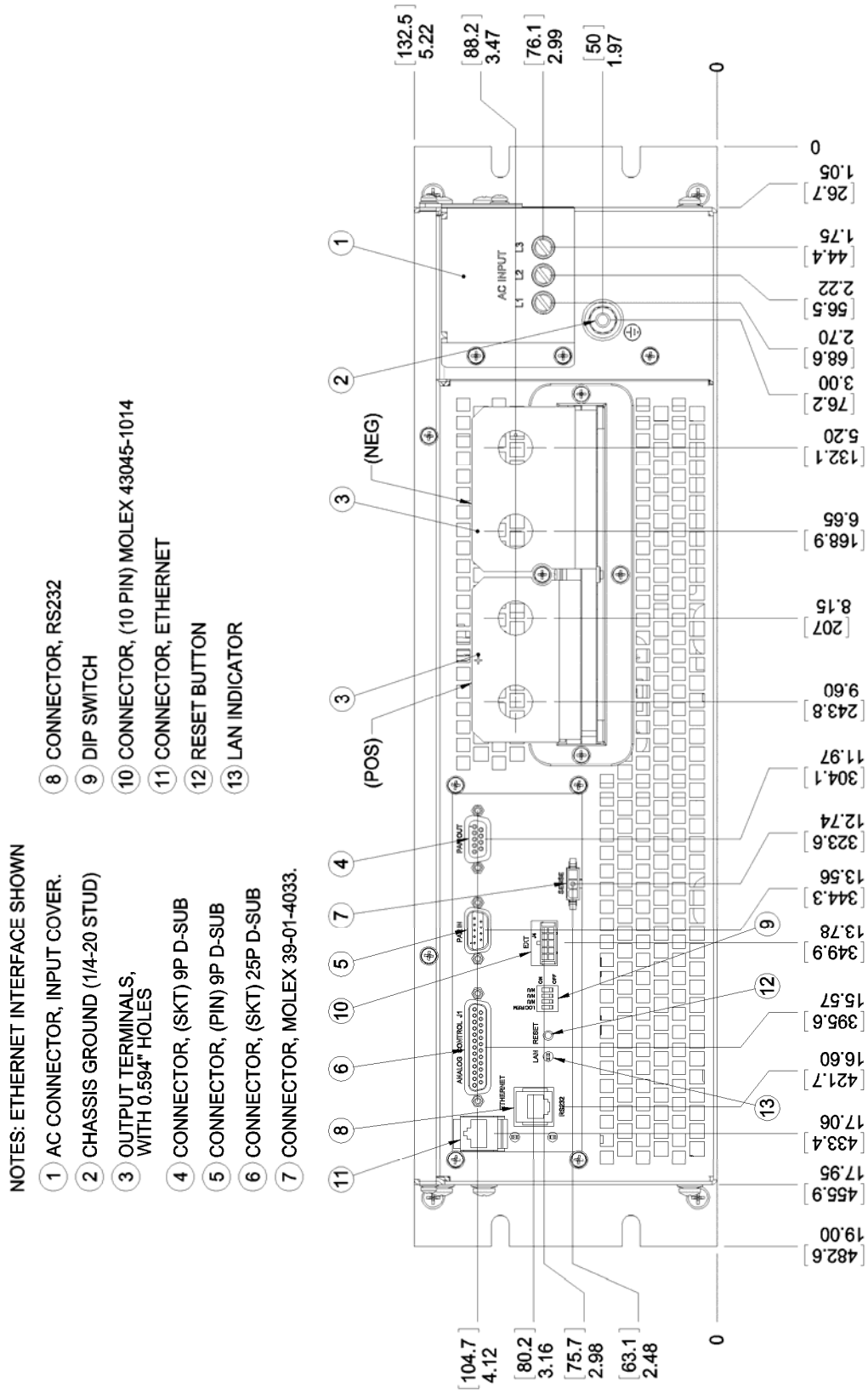

Figure 2-10. Rear Panel, Ethernet Option, 3U Models 10V-30V

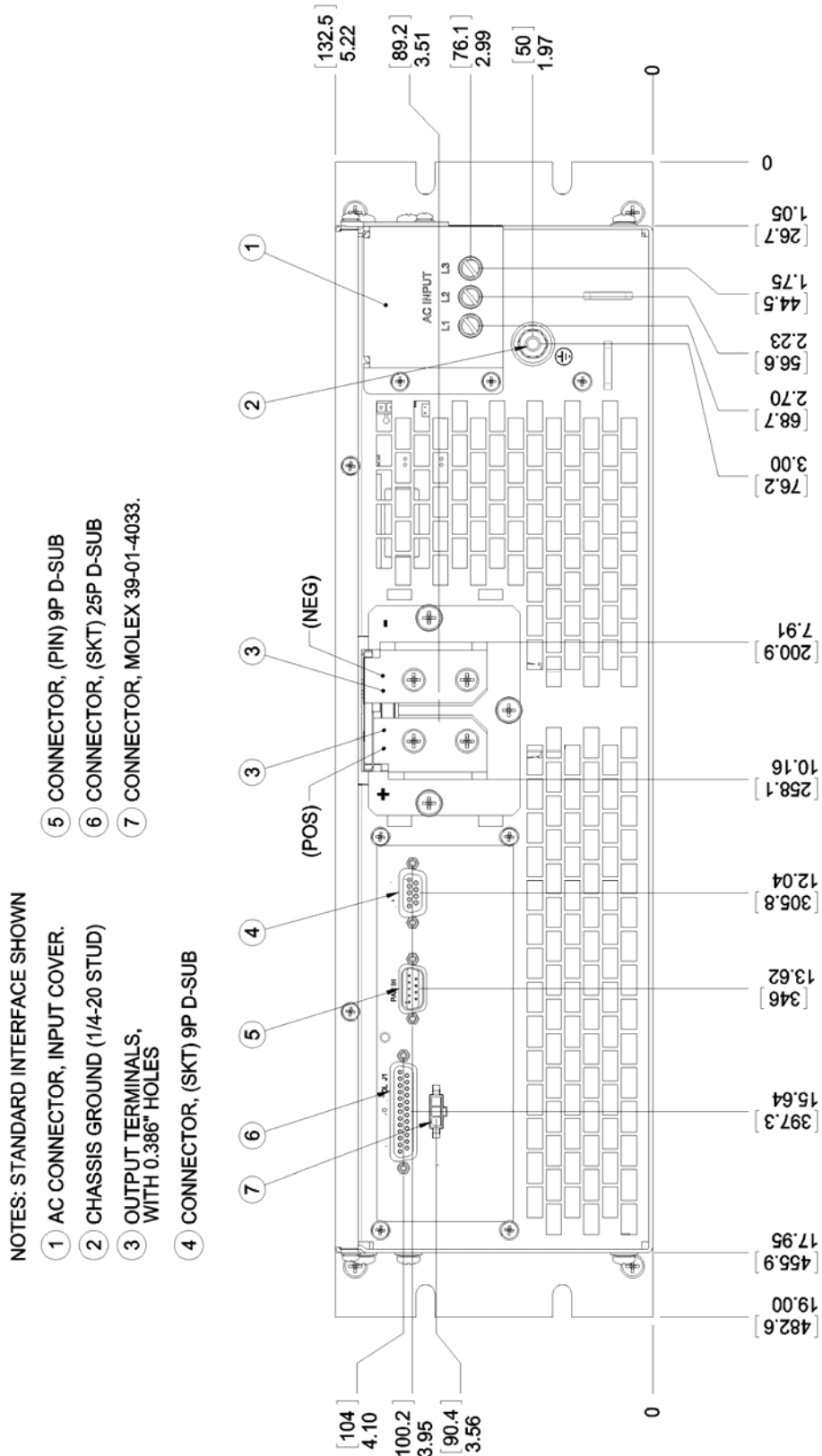

Figure 2-11. Rear Panel, Standard, 3U Models 40V-600V

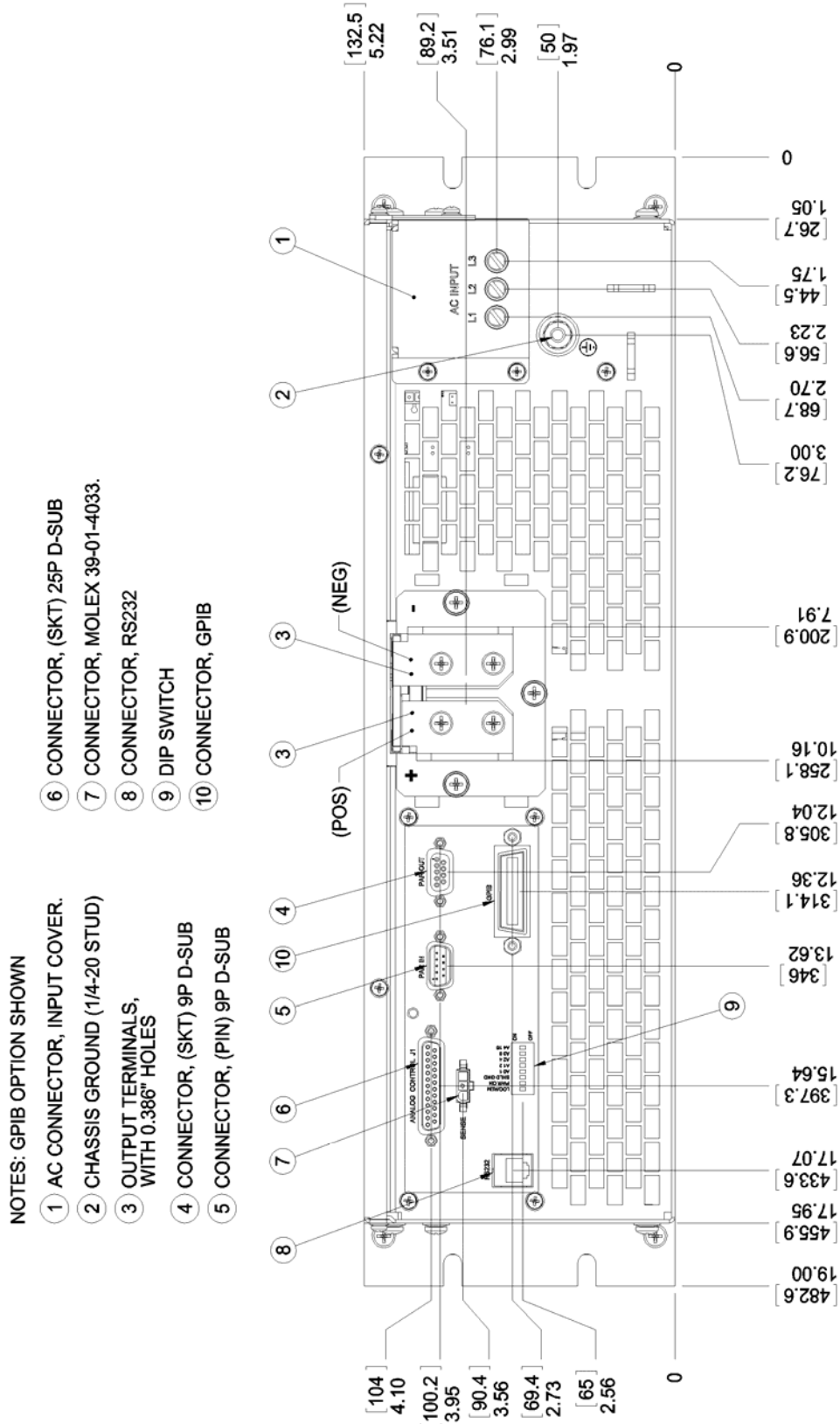

Figure 2-12. Rear Panel, GPIB Option, 3U Models 40V-600V

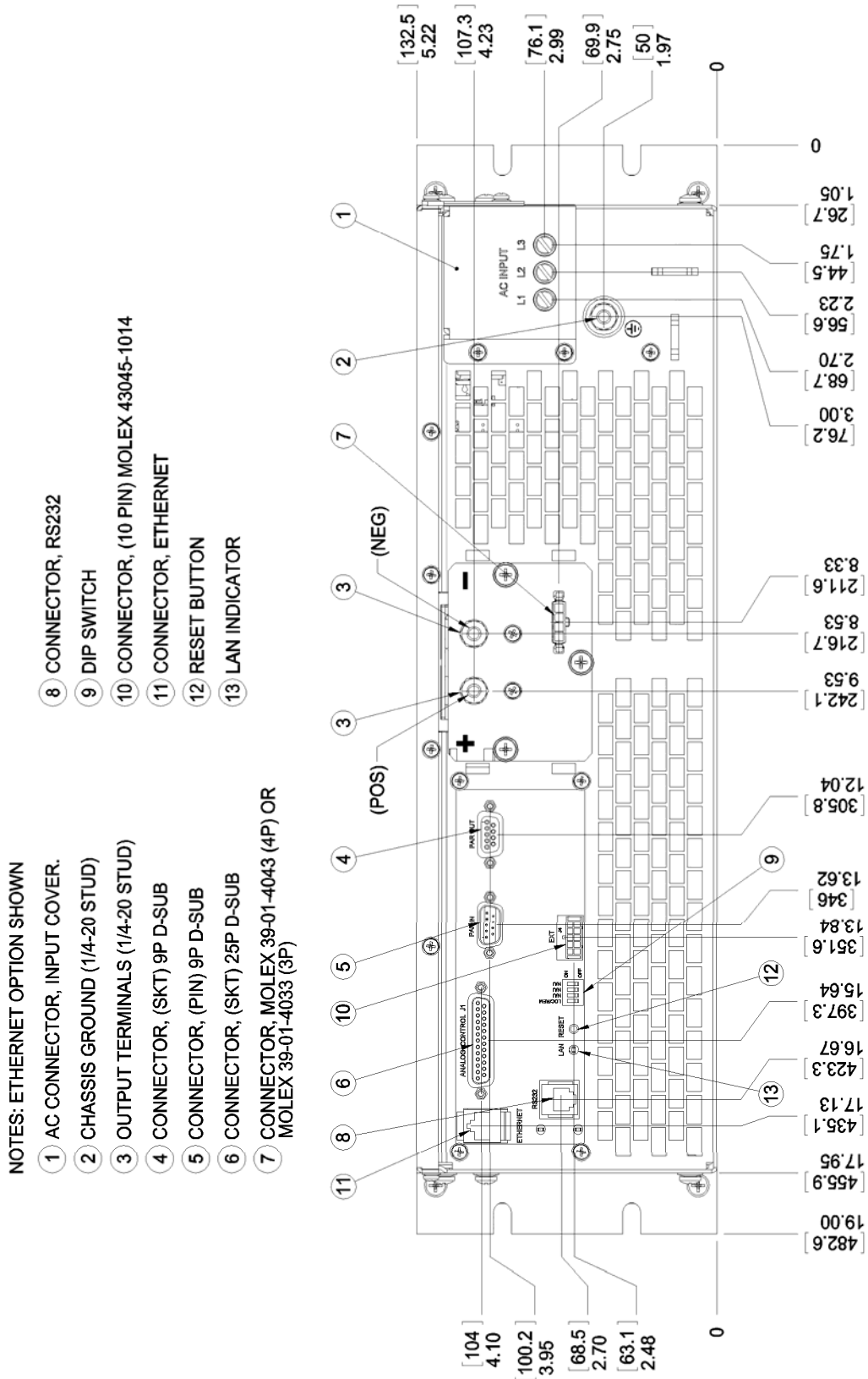

Figure 2-13. Rear Panel, Ethernet Option, 3U Models 800V and 1000V

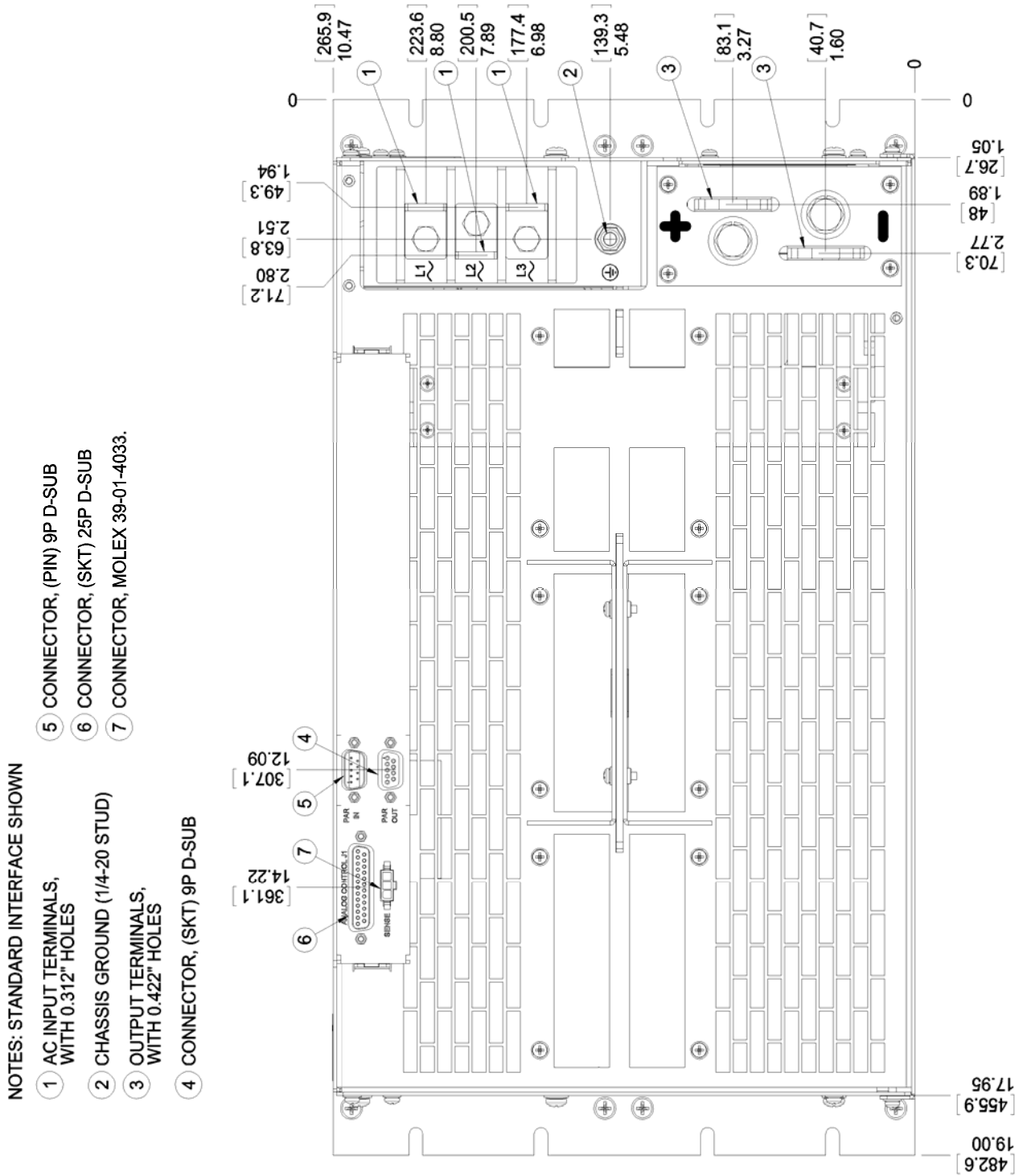

Figure 2-14. Rear Panel, Standard, 6U Models 20kW-30kW

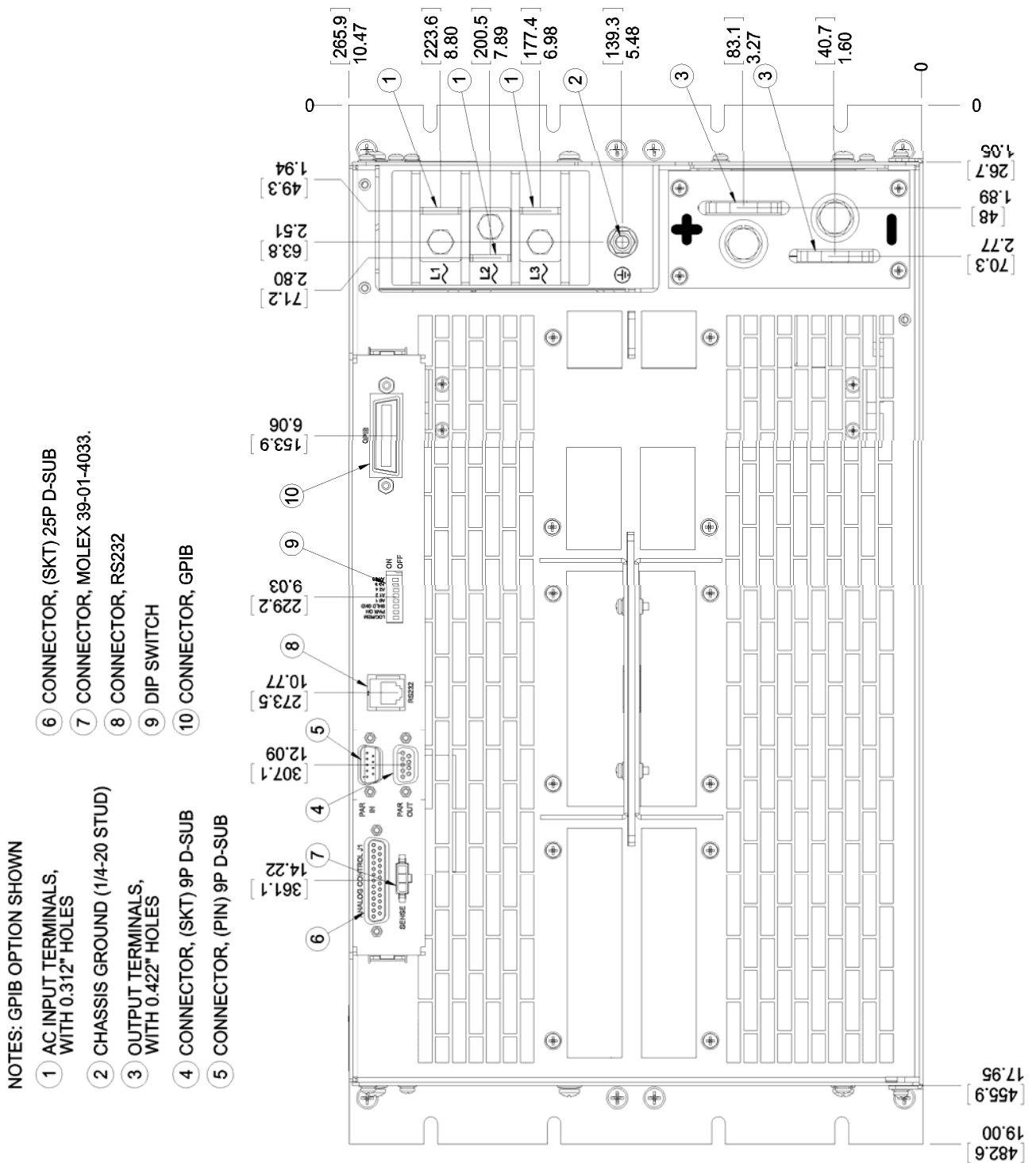

Figure 2-15. Rear Panel, GPIB Option, 6U Models 20kW-30kW

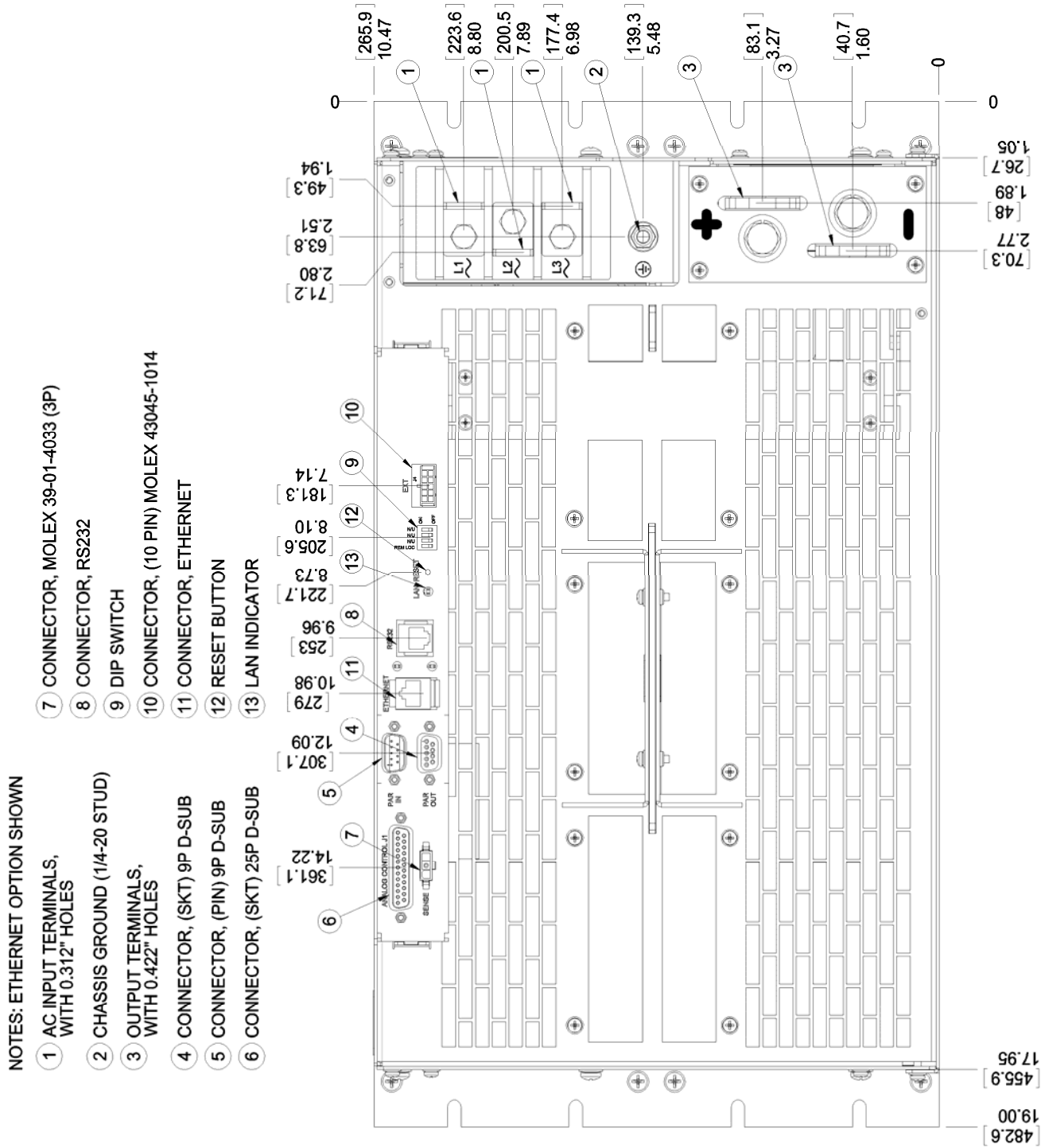

Figure 2-16. Rear Panel, Ethernet Option, 6U Models 20kW-30kW

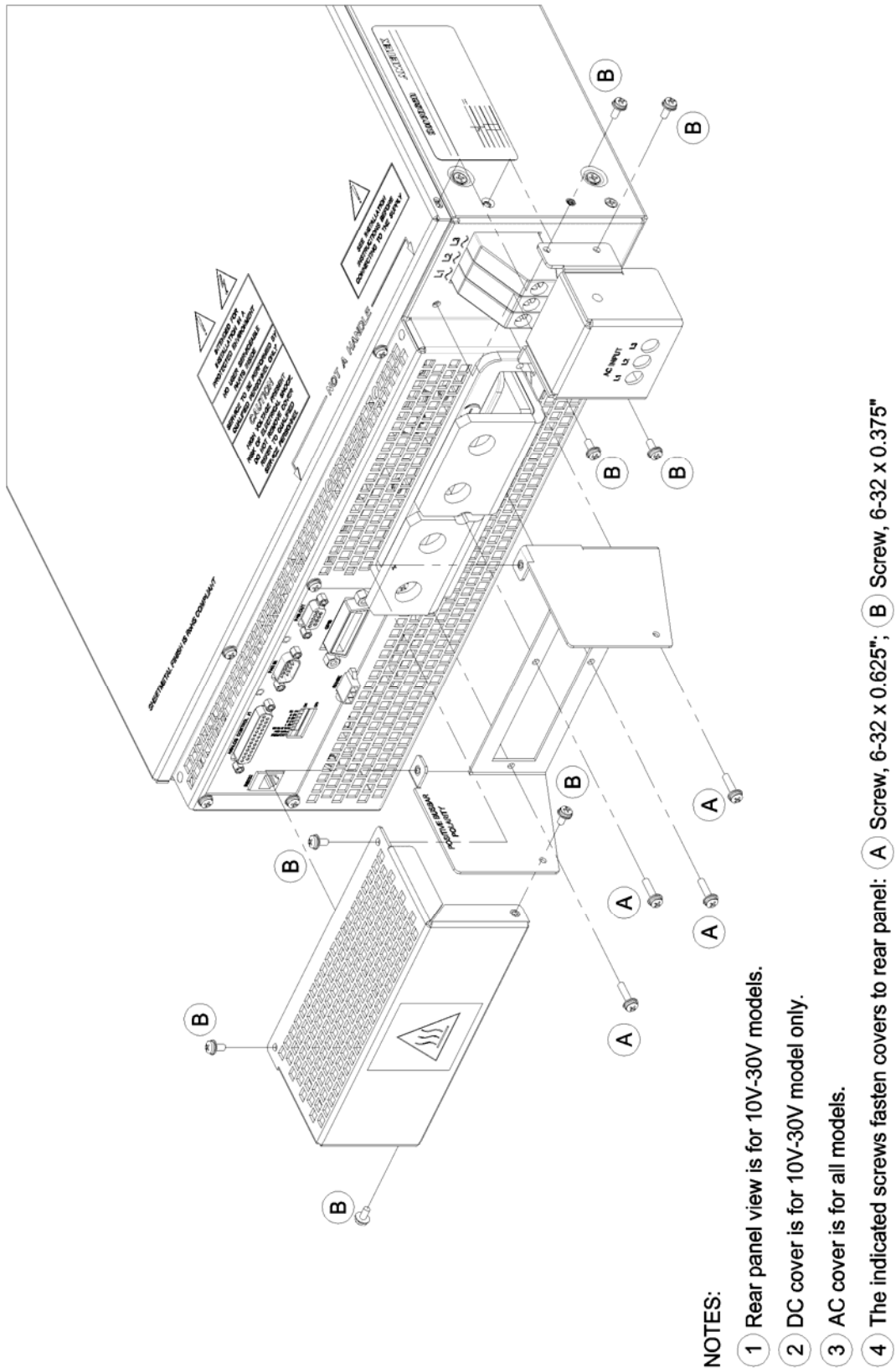

Figure 2-17. Instructions for Assembly of AC and DC Covers

This page intentionally left blank.

SECTION 3 OPERATION

3.1 INTRODUCTION

The SGe series provides simplicity and ease of use through analog front panel potentiometer controls. LED meters display bright, easy-to-read voltage and current output measurements. This section provides detailed information on the controls and indicators, and the operation of the SGe Series.

3.1.1 FRONT/REAR PANELS

Figure 3-1 shows the front panel of the 3U models; the 6U models have the same controls and indicators. Figure 3-2 through Figure 3-10 show the rear panels of the 3U and 6U models, with their connectors and controls.

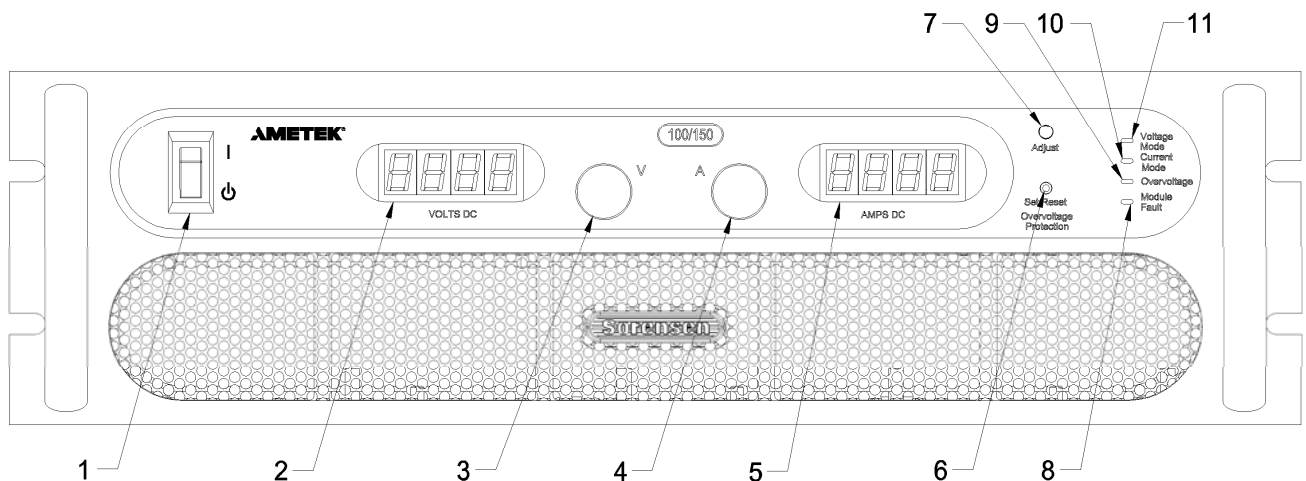



Figure 3-1. Front Panel Controls and Indicators (3U Model Shown)

	<p>WARNING!</p> <p>The power-up factory default state is output enabled, where the output will be energized at the settings of voltage and current.</p>
---	--

Item	Reference	Functional Description
1	ON/OFF Switch	<p>Two-position switch turns the power supply on and off.</p> <div style="border: 1px solid black; padding: 5px; margin: 10px auto; width: fit-content;"> <p style="text-align: center;">WARNING!</p> <p style="text-align: center;">  OFF position does not remove AC input from internal circuits or input terminal blocks. Disconnect external AC input before servicing unit. </p> </div>
2	Voltage Display	3½ digit green LED display for the DC output voltage. Also displays the OVP level when pressing the Set/Reset button.
3	Voltage (V) Knob	10-turn adjustment sets the output voltage. (Optional shaft locks not shown; see Section 3.2.)
4	Current (A) Knob	10-turn adjustment sets the output current. (Optional shaft locks not shown; see Section 3.2.)
5	Current Display	3½ digit green LED display for the DC output current.
6	Set/Reset Button	Press to display Overvoltage Protection level on the Voltage display. Press and hold for 7 s to reset OVP condition.
7	Adjust Potentiometer	Adjusts the overvoltage trip level.
8	Module Fault LED	Lights yellow to indicate an internal fault in a power module, such as overtemperature, undervoltage of AC input, or converter failure.
9	Overvoltage LED	Lights red when output voltage has exceeded preset level, and power supply output is turned off.
10	Current Mode LED	Lights green when in the Constant-Current mode of operation: the output current will regulate to the set value and the output voltage will vary with the load.
11	Voltage Mode LED	Lights green when in the Constant-Voltage mode of operation: the output voltage will regulate to the set value and the output current value will vary with the load.

Table 3–1. Front Panel Controls and Indicators

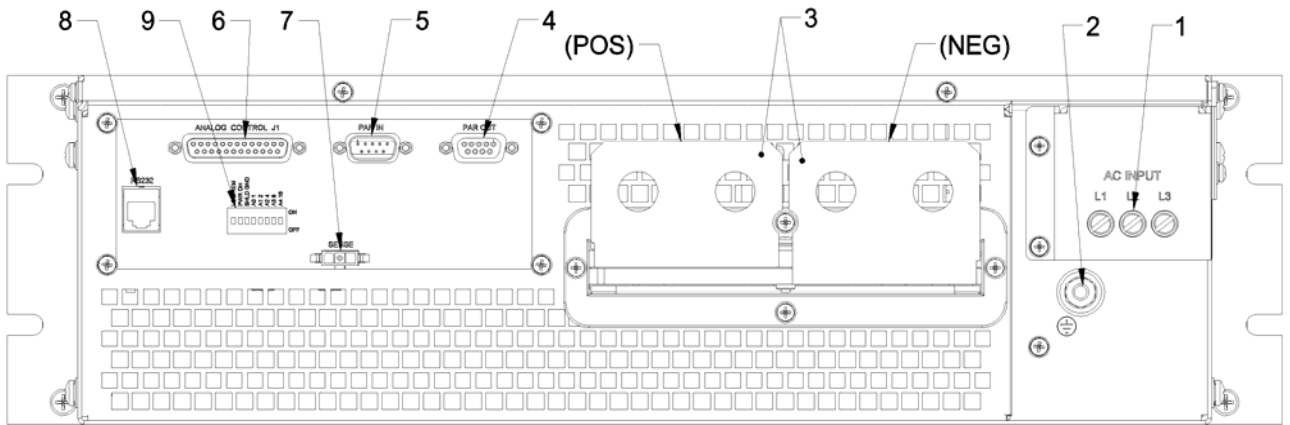

Figure 3-2. Rear Panel Interface, Standard, 3U Models 10V-30V

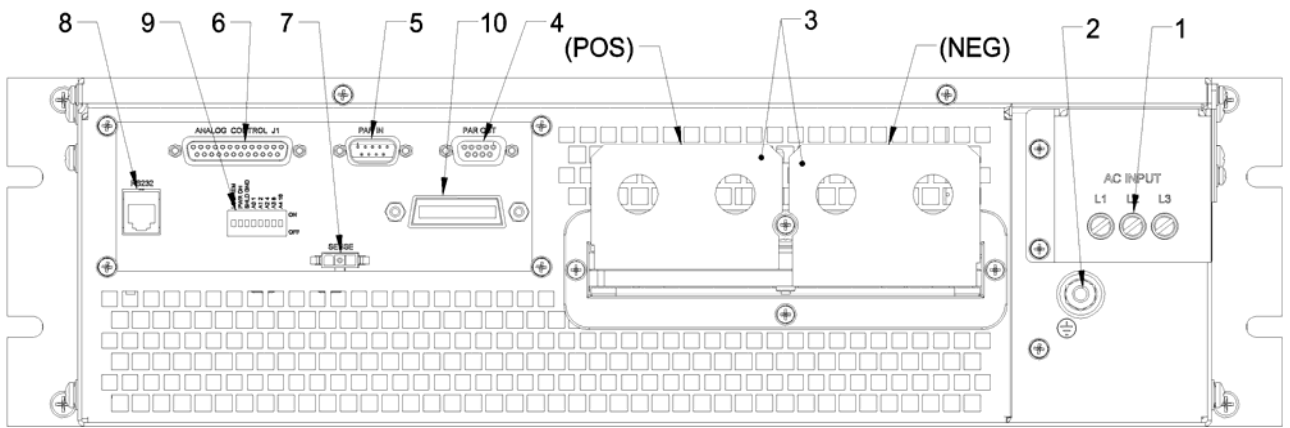

Figure 3-3. Rear Panel Interface, GPIB Option, 3U Models 10V-30V

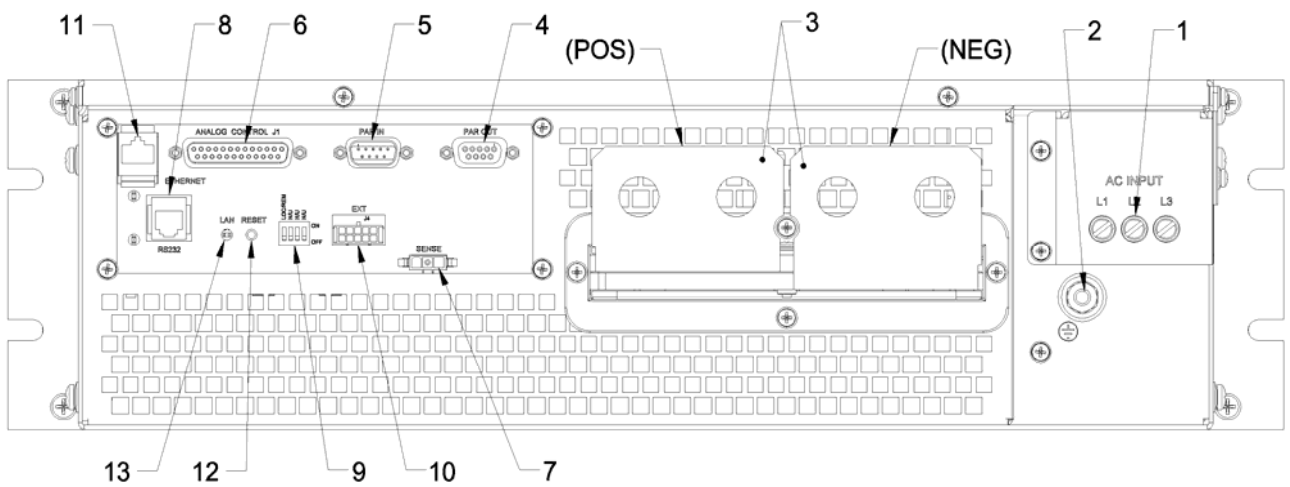

Figure 3-4. Rear Panel Interface, Ethernet Option, 3U Models 10V-30V

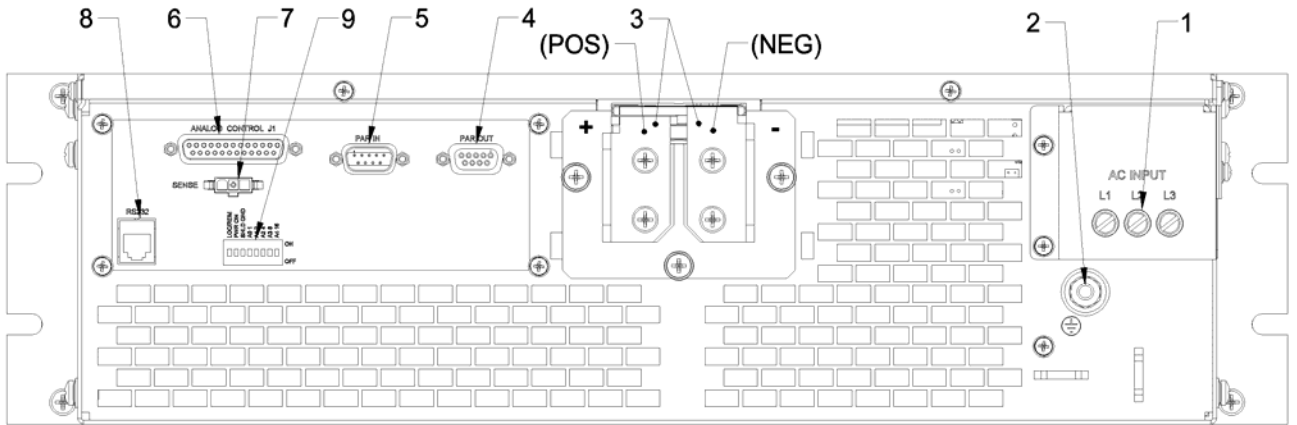

Figure 3-5. Rear Panel Interface, Standard, 3U Models 40V-600V

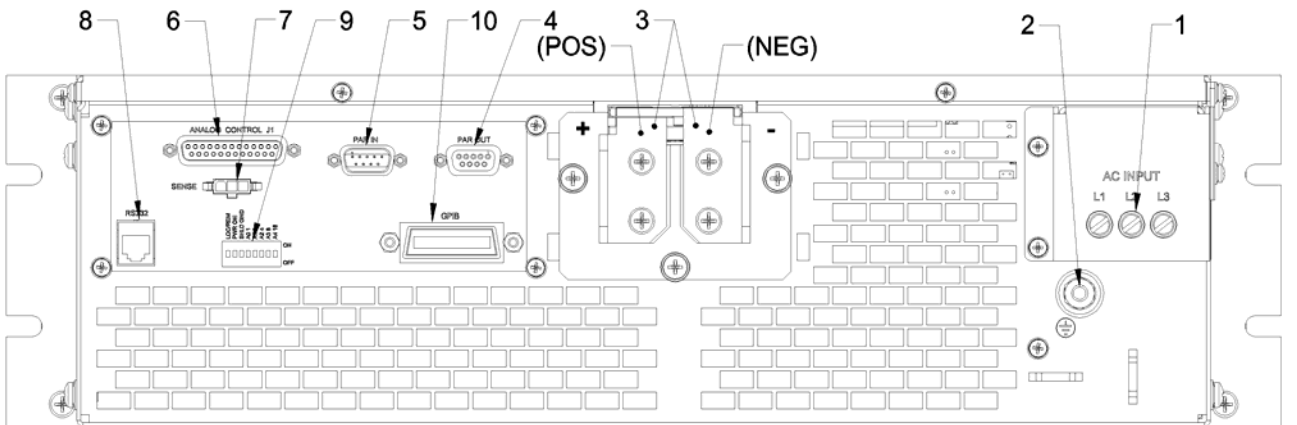

Figure 3-6. Rear Panel Interface, GPIB Option, 3U Models 40V-600V

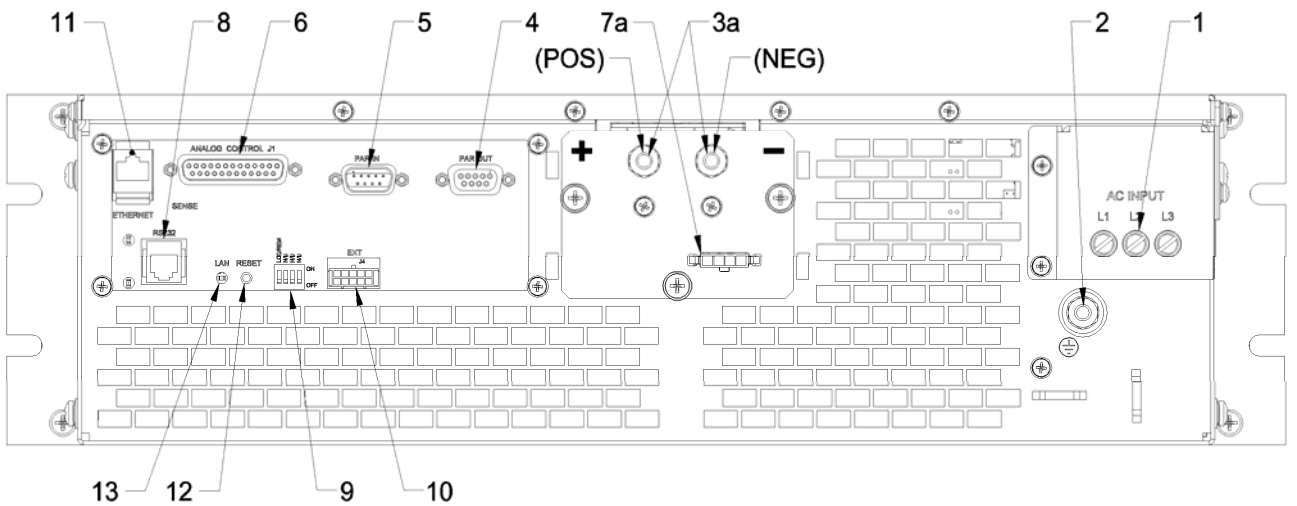

Figure 3-7. Rear Panel Interface, Ethernet Option, 3U Models 800V and 1000V

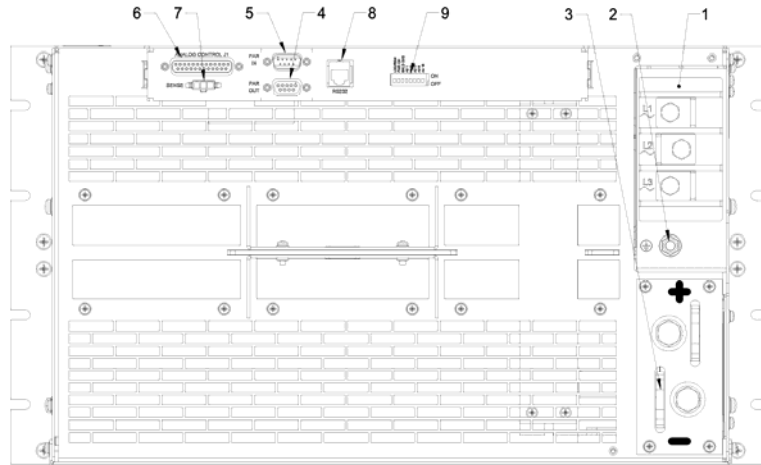

Figure 3-8. Rear Panel Interface, Standard, 6U Models 20kW-30kW

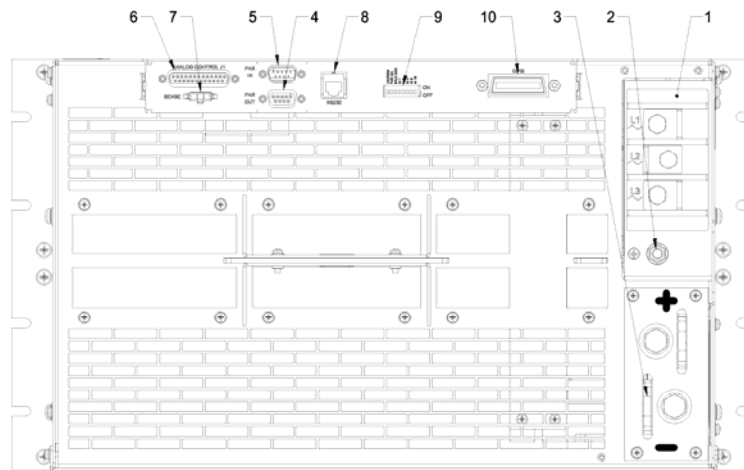

Figure 3-9. Rear Panel Interface, GPIB Option, 6U Models 20kW-30kW

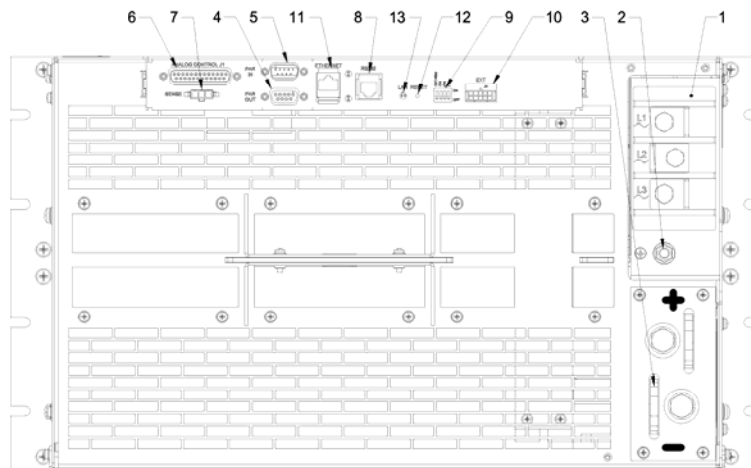

Figure 3-10. Rear Panel Interface, Ethernet Option, 6U Models 20kW-30kW

Item	Reference	Functional Description
1	AC Input Connectors	Connection for 3-phase AC.
2	AC Input Safety Ground	Connection for safety ground wire.
3	DC Output Bus Bars	Positive (+) and negative (–) outputs.
3a	HV DC Output Studs	Positive (+) and negative (–) outputs for 800V and 1000V models only.
4	PAR OUT	Parallel Out connector of master unit for configuring parallel operation of units when connected to Parallel In connector of slave unit; see Section 3.11.
5	PAR IN	Parallel In connector of slave unit for configuring parallel operation of units when connected to Parallel Out connector of master unit; see Section 3.11.
6	ANALOG CONTROL	Remote Analog Interface connector, J1, for programming and monitoring signals of output, status indication, and remote shutdown signals; see Table 3–5 for individual pin descriptions.
7	SENSE Connector	Input connector, J3, for remote sensing of voltage at the load to compensate for line drop in load cables; see Section 3.9.
7a	HV SENSE Connector	Input connector, J3, for remote sensing of voltage at the load to compensate for line drop in load cables, 800V and 1000V models only; see Section 3.9.
Refer to Figure 3-2, Figure 3-5, and Figure 3-8.		

Table 3–2. Rear Panel Connectors and Controls, Standard

Item	Reference	Functional Description
1	AC Input Connectors	Connection for 3-phase AC.
2	AC Input Safety Ground	Connection for safety ground wire.
3	DC Output Bus Bars	Positive (+) and negative (-) outputs.
3a	HV DC Output Studs	Positive (+) and negative (-) outputs for 800V and 1000V models only.
4	PAR OUT	Parallel Out connector of master unit for configuring parallel operation of units when connected to Parallel In connector of slave unit; see Section 3.11.
5	PAR IN	Parallel In connector of slave unit for configuring parallel operation of units when connected to Parallel Out connector of master unit; see Section 3.11.
6	ANALOG CONTROL	Remote Analog Interface connector, J1, for programming and monitoring signals of output, status indication, and remote shutdown signals; see Table 3-5 for individual pin descriptions.
7	SENSE Connector	Input connector, J3, for remote sensing of voltage at the load to compensate for line drop in load cables; see Section 3.9.
7a	HV SENSE Connector	Input connector, J3, for remote sensing of voltage at the load to compensate for line drop in load cables, 800V and 1000V models only; see Section 3.9.
8	RS-232 Connector [†]	RS-232 connector for remote digital control.
9	Configuration Switch [†]	Eight-position DIP switch to configure the digital interface of the unit
10	GPIB Connector [†]	GPIB connector for remote digital control.
Refer to Figure 3-3, Figure 3-6, and Figure 3-9.		
[†] Refer to the Programming Manual for details on the digital interface.		

Table 3-3. Rear Panel Connectors and Controls, GPIB Option

Item	Reference	Functional Description
1	AC Input Connectors	Connection for 3-phase AC.
2	AC Input Safety Ground	Connection for safety ground wire.
3	DC Output Bus Bars	Positive (+) and negative (-) outputs.
3a	HV DC Output Studs	Positive (+) and negative (-) outputs for 800V and 1000V models only.
4	PAR OUT	Parallel Out connector of master unit for configuring parallel operation of units when connected to Parallel In connector of slave unit; see Section 3.11.
5	PAR IN	Parallel In connector of slave unit for configuring parallel operation of units when connected to Parallel Out connector of master unit; see Section 3.11.
6	ANALOG CONTROL	Remote Analog Interface connector, J1, for programming and monitoring signals of output, status indication, and remote shutdown signals; see Table 3-5 for individual pin descriptions.
7	SENSE Connector	Input connector, J3, for remote sensing of voltage at the load to compensate for line drop in load cables; see Section 3.9.
7a	HV SENSE Connector	Input connector, J3, for remote sensing of voltage at the load to compensate for line drop in load cables, 800V and 1000V models only; see Section 3.9.
8	RS-232 Connector [†]	RS-232 connector for remote digital control.
9	Configuration Switch [†]	Four-position DIP switch to configure the digital interface of the unit
10	External User Connector [†]	Input/Output connector for external auxiliary digital control signals.
11	ETHERNET Connector [†]	Ethernet connector for remote digital control.
12	RESET Switch [†]	Reset switch to return configuration parameters to factory default settings; must be depressed until LAN LED is blinking.
13	LAN [†]	LED indicator: continuously on indicates Ethernet connection; off indicates no Ethernet connection; blinking indicates Instrument ID.
Refer to Figure 3-4, Figure 3-7, and Figure 3-10.		
[†] Refer to the Programming Manual for details on the digital interface.		

Table 3-4. Rear Panel Connectors and Controls, Ethernet Option

3.2 SHAFT LOCK (OPTION)

This option replaces the standard control knobs with a two-piece shaft lock. These are installed over the voltage and current adjustment potentiometer shafts to prevent rotating under conditions of shock, vibration, or accidental contact. For adjustment, the following steps apply:

- Loosen the shaft by rotating the outer locking nut counter-clockwise with a 7/16" wrench.
- Adjust the shaft with a flat screwdriver to the desired output level.
- Tighten the outer locking nut, rotating clockwise, to approximately 5 in-lb (0.56 N-m).

Note: Take care not to over-torque the outer nut. Should the cone nut become loose or jammed with the outer locking nut, re-torque the cone nut with a 1/2" wrench to approximately 15 in-lb (1.69 N-m).



CAUTION!

Never fully loosen the cone nut, or remove the shaft lock from the chassis.

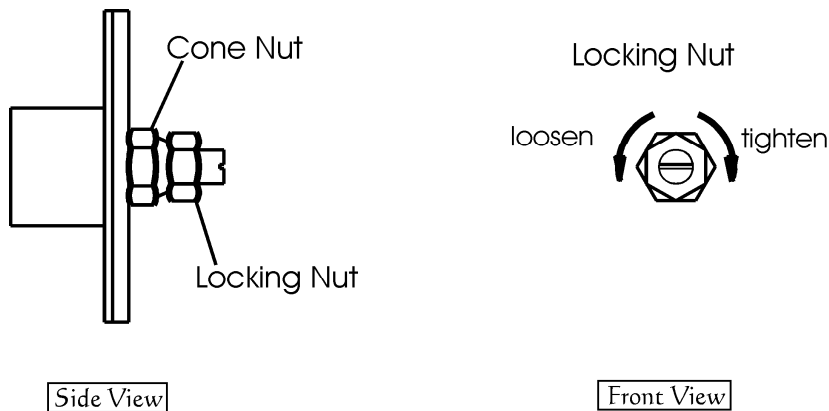

Figure 3-11. Shaft Lock

3.3 FRONT PANEL OPERATION

The SGe Series power supply is shipped from the factory configured for front panel voltage/current/OVP control, and with the remote sense not connected (default to internal voltage sensing at chassis output terminals). The remote sense leads must be connected externally by the user to achieved performance specifications. The Analog Control connector (J1) is fitted with a mating connector which has the remote output ON/OFF control signals jumpered for ON (Pin-5 connected to Pin-6) in order to allow the output to be enabled.



WARNING!

The power-up factory default state is output enabled, where the output will be energized at the settings of voltage and current.

1. Prior to turning the unit on, rotate the voltage and current potentiometers fully counterclockwise (minimum output), if output settings are not certain and load would not tolerate full rated output voltage of the power supply.
2. Adjust the voltage and current from the minimum setting to the desired output after turning ON the unit.

3.3.1 INITIAL SETUP

1. Before connecting the unit to the AC mains, ensure that the front panel ON/OFF power switch is in the OFF position.
2. Ensure that the Voltage and Current control knobs are fully counterclockwise.
3. Check the ANALOG CONTROL (J1) mating connector on the rear panel to verify that Pins 5 and 6 (Remote Output On/Off) are shorted together to enable the output of the supply (see Section 3.8). This is the default configuration installed from the factory.
4. Apply power to the AC mains input.

3.3.2 CONSTANT-VOLTAGE MODE OPERATION

When the power supply is in the Constant-Voltage mode, it functions as a voltage source, and the output voltage of the supply is controlled by the Voltage knob on the front panel or by the remote analog voltage programming input; see Section 3.6. The output voltage is regulated at the selected value while the output current varies with the load requirements. The Current knob (or remote current programming input) sets the maximum level of output current before mode transition would automatically occur to Constant-Current operation. To verify operation in Constant-Voltage mode, follow the steps below:

1. Ensure that there is no load connected to the output.
2. Ensure that the remote sense is connected to the output terminals.
3. Connect a digital voltmeter (DVM) across the rear panel positive and negative output terminals, observing the correct polarity. Make sure the DVM is in the DC voltage mode and the range is adequate to handle the full-scale voltage of the power supply.
4. Rotate the Current control knob about 1/2 turn clockwise (this adjusts the current setting to a value above zero to ensure ability to supply current)
5. Switch the power supply on.
6. Slowly rotate the Voltage knob clockwise and observe both the front panel voltage display and the output of the DVM. The output voltage should increase from 0 V to the maximum rated voltage of the supply. The front panel display and DVM readings should track within the accuracies of the meter and the front panel display.
7. Check that the green Voltage Mode LED is on.
8. Turn the Voltage knob and Current knob fully counterclockwise.
9. Switch the power supply off.
10. If Constant-Voltage mode operation did not function as indicated above, verify your setup and perform the check again. If the function continues to fail, contact the factory for assistance at Sorensen.ppd@ametec.com.

3.3.3 CONSTANT-CURRENT MODE OPERATION

When the power supply is in the Constant-Current Mode, it functions as a current source, and the output current of the supply is controlled by the Current knob on the front panel or by the remote analog current programming input; see Section 3.5. The output current is regulated at the selected value while the output voltage varies with the load requirements. The Voltage knob (or remote voltage programming input) sets the maximum level of output voltage before mode transition would automatically occur to Constant-Voltage operation. To verify operation in Constant-Current mode, follow the steps below:

1. If the output had been previously energized, allow 5 minutes for the output capacitors to discharge. Connect a high current DC ammeter across the rear panel positive and negative output terminals, observing the correct polarity.
2. Select wire leads of sufficient current carrying capacity and an ammeter range compatible with the full-scale rated output current of the unit.
Note: It could be verified that the supply could source rated output current, without measuring the current with an ammeter, but using only the front panel meter, and shorting the output terminals together.
3. Rotate the Voltage control knob about 1/2 turn clockwise (this adjusts the voltage setting to a value above zero to ensure ability to supply voltage)
4. Switch the power supply on.
5. Slowly rotate the Current knob clockwise and observe both the front panel current display and the output of the ammeter. The output current should increase from 0 A to the maximum rated current of the supply. The front panel display and ammeter readings should track within the accuracies of the meter and the front panel display.
6. Check that the green Current Mode LED is on.
7. Turn the Voltage knob and Current knob fully counterclockwise.
8. Switch the power supply off.
9. Allow 5 minutes for the output capacitors to discharge and disconnect the ammeter or short from the output terminals.
10. If Constant-Current Mode operation did not function as indicated above, verify your setup and perform the check again. If the function continues to fail, contact the factory for assistance at Sorensen.ppd@ametec.com.

3.3.4 OVERVOLTAGE PROTECTION

The Overvoltage Protection (OVP) function allows the supply to shutdown the output, if it were to exceed a preset voltage. This may be used to protect sensitive circuits or loads from damage caused by an excessive voltage on the output of the supply. The Overvoltage Protection (OVP) could be set either with the front panel potentiometer or by the remote analog OVP programming input; see Section 3.7. To verify OVP operation, follow the steps below:

1. Make sure there is nothing connected across the output terminals.
2. Rotate the Current control knob about 1/2 turn clockwise (this adjusts the current setting to a value above zero to ensure ability to supply current).
3. Switch the power supply on.
4. Press and hold the Set/Reset Overvoltage Protection pushbutton on the front panel and observe the reading on the voltage display. This is the present setting of the OVP limit. The factory default setting is approximately 110% of the maximum rated output voltage of the supply.
5. While holding down the Set/Reset button, use a small flat-blade adjustment screwdriver to adjust the OVP setting by turning the multi-turn recessed adjustment potentiometer counterclockwise. As the potentiometer is adjusted, the reading on the voltage display should decrease (increase, if adjusted in a clockwise direction).
6. Set the OVP to about 80-90% of the maximum rated output voltage and record the OVP voltage value.
7. Release the Set/Reset pushbutton.
8. Rotate the Voltage knob clockwise until the voltage display indicates about 2-3% below the OVP voltage value recorded above.
9. Slowly continue to increase the output of the supply until the value of the OVP setting is exceeded.
10. Check that the OVP LED lights and that the output of the supply powers down to 0 V (as indicated on the Voltage display).
11. Turn the Voltage knob fully counterclockwise, then press and hold the Set/Reset pushbutton until the OVP LED is no longer lit.
12. Reset the OVP setting as appropriate for your application per steps 4 and 5 above. If you do not choose to use OVP, then the OVP adjust may be set fully clockwise to approximately 110% of the rated output voltage of the supply.

13. If OVP mode did not function as indicated above, verify your setup and perform the check again. If the function continues to fail, contact the factory for assistance at Sorensen.ppd@ametek.com.

3.4 REMOTE ANALOG CONTROL CONNECTOR (J1)

The Analog Control connector (J1) of the Remote Analog Interface on the rear panel allows the unit to be configured for different operating configurations: front panel and remote current programming, front panel and remote voltage programming, output current and voltage monitoring, output enable/disable, etc. Refer to Figure 3-12 for the connector pin-out diagram. The setup and operating requirements of each configuration are provided in Sections 3.5 through 3.8.3.



CAUTION!

In the standard, Remote Non-Isolated Analog Interface, the programming/control circuits (signal returns through J1-6 and J1-24) are electrically connected to the output power negative terminal of the supply (not isolated). Proper connection of signal returns must be made with respect to external programming/control equipment to ensure that ground/return loops are not formed where output load current might flow through the external connections to the J1 circuits (J1-6 and J1-24), possibly causing internal damage to the power supply. Refer to Table 3-5.

REMOTE ISOLATED ANALOG INTERFACE CONTROL (OPTION)

The option, Remote Isolated Analog Interface control, uses the same Analog Control connector (J1) as the standard interface. However, this option fully isolates the remote control signals and allows control of units not connected to a common ground. Control signal returns are isolated from output power negative terminal, which protects against potential damage from systems with high energy electrical potentials or large ground loop currents.

Note: Some standard, Non-Isolated Analog Interface programming signals are not available with this option; see Table 3-5 for details.



CAUTION!

The Remote Isolated Analog Interface option is not intended to allow operation of the power supply at excessive voltages. Operation of Isolated Analog Interface signals should be at SELV safety voltage conditions to chassis ground. Refer to Section 1.2.2 for maximum terminal voltages.

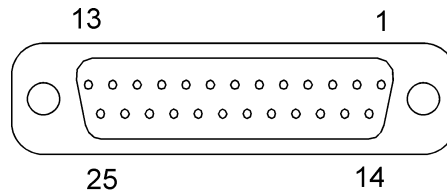

Figure 3-12. Analog Control Connector (J1) Pin-Out

Pin	Reference	Electrical Parameters	Functional Description
1	ISO ON/OFF	Zin ~ 6 k Ω in series with anode of opto-isolator LED	Isolated remote control input for output on/off with an applied AC/DC voltage source. A positive (+) 6-120 VDC or an AC input of 12- 240 VAC will enable (turn-on) the output of the supply. This control input is optically isolated from the output power negative terminal of the power supply (up to 500 VDC). Signal return is Pin J1-2 (ISO RTN). See Section 3.8.
2	ISO RTN	—	Isolated signal return for on/off control using Pins J1-1 and J1-14. Optically isolated from the output power negative terminal of the power supply (up to 500 VDC).
3	REM OV SET	Zin ~ 20 k Ω	Control input for remote programming of the overvoltage protection: 0.25-5.5 VDC = 5-110% of full-scale output voltage. Reset of an OVP condition is possible by applying an 10.5-13.3 VDC signal for 7 seconds. Signal return is Pin J1-6 (COM). Circuit is electrically connected to the output power negative terminal. See Section 3.7.
4	VP RTN	Zin ~ 10 k Ω	Voltage programming signal return to be used with Pins J1-9, J1-15 or J1-21; also must be externally connected to Pin J1-6 (COM) signal return when voltage programming is utilized. Circuit is electrically connected to the output power negative terminal.
5	ON/OFF	Zin ~ 10 k Ω pull-up to 15 VDC	Remote control input for output on/off: switch/relay contact closure or direct short-circuit from this terminal to Pin J1-6 (COM) signal return will enable (turn-on) the output of the supply; remote circuit must sink up to 1.5 mA from 15 VDC to enable. Circuit is electrically connected to the output power negative terminal. See Section 3.8.
6	COM †	—	Signal return. Internally connected to Pin J1-24. Circuit is electrically connected to the output power negative terminal.
7	I MON	Zout ~ 100 Ω	Monitor signal for output current: 0-10 VDC = 0-100% of full-scale output current. Minimum recommended load resistance is 100 k Ω . Circuit return is Pin J1-6 (COM). Circuit is electrically connected to the output power negative terminal.
8	V SET *	Zout ~ 100 Ω	Monitor signal for front panel voltage potentiometer setpoint: 0-5 VDC = 0-100% of full-scale setpoint. Minimum recommended load resistance is 100 k Ω . Signal return is Pin J1-6 (COM). Circuit is electrically connected to the output power negative terminal.
9	VP 5V	Zin ~ 10 k Ω	Control input for remote voltage programming using a voltage source: 0-5 VDC = 0-100% of full-scale output voltage. Do not exceed an input of 13.3 VDC. Signal return is Pin J1-4 or

Pin	Reference	Electrical Parameters	Functional Description
			Pin J1-20 (VP RTN). Circuit is electrically connected to the output power negative terminal. See Section 3.6.
10	IP 5V	Zin ~ 10 k Ω	Remote control input for current programming using a voltage source: 0-5 VDC = 0-100% of full-scale output current. Do not exceed an input of 13.3 VDC. Signal return is Pin J1-23 or Pin J1-25 (IP RTN). Circuit is electrically connected to the output power negative terminal. See Section 3.5.
11	ISET *	Zout ~ 100 Ω	Monitor signal for front panel current potentiometer setpoint: 0-5 VDC = 0-100% of full-scale setpoint. Minimum recommended load resistance is 100 k Ω . Signal return is Pin J1-6 (COM). Circuit is electrically connected to the output power negative terminal.
12	Not Used		
13			
14	ISO TTL/CMOS	Zin ~ 900 Ω in series with anode of opto-isolator LED	Isolated remote control input for output on/off with a logic signal: a logic-high, 5 VDC TTL/CMOS signal will enable (turn-on) the output of the supply, and a logic-low signal disables (turns off) the output. This control input is optically isolated from the output power negative terminal of the power supply (up to 500 VDC). Signal return is Pin J1-2 (ISO RTN). See Section 3.8.
15	VP 10V	Zin ~ 20 k Ω	Remote control input for voltage programming using a voltage source: 0-10 VDC = 0-100% of full-scale output voltage. Do not exceed an input of 25 VDC. Signal return is Pin J1-4 or Pin J1-20 (VP RTN). Circuit is electrically connected to the output power negative terminal. See Section 3.6.
16	IP 10V	Zin ~ 20 k Ω	Remote control input for current programming using a voltage source: 0-10 VDC = 0-100% of full-scale output current. Do not exceed an input of 25 VDC. Signal return is Pin J1-4 or Pin J1-20 (VP RTN). Circuit is electrically connected to the output power negative terminal. See Section 3.5.
17	FAULT	Zout ~ 1 k Ω	Output signal for indicating a fault state: a logic-high state (approximately +10 VDC) indicates a fault has occurred in a power module, such as overtemperature, undervoltage of AC input, or converter failure; front panel Fault LED will also be lit. Signal return is Pin J1-6 (COM). Circuit is electrically connected to the output power negative terminal.
18	S/D FAULT	Zout ~ 100 Ω	Output signal for shutdown/fault state: a logic-high state indicates shutdown produced by an OVP condition, Power-On-Reset (POR), remote disable, or housekeeping supply fault. An 8 VDC minimum output signal is provided into a load of 10 k Ω load. Signal return is Pin J1-6 (COM). Circuit is electrically connected to the output power negative terminal. See Section 3.8.3.
19	V MON	Zout ~ 100 Ω	Monitor signal for output voltage: 0-10 VDC = 0-100% of full-scale output voltage. Minimum recommended load resistance is 100 k Ω . Circuit return Pin J1-6 (COM). Circuit is electrically connected to the output power negative terminal.

Pin	Reference	Electrical Parameters	Functional Description
20	VP RTN	$Z_{in} \sim 10 \text{ k}\Omega$	Voltage programming signal return to be used with Pins J1-9, J1-15 or J1-21; also must be externally connected to Pin J1-6 (COM) signal return when voltage programming is utilized. Circuit is electrically connected to the output power negative terminal.
21	VP RES *	1mA current source with compliance voltage of $\sim 10.8 \text{ V}$	Current source of 1 mA for remote voltage programming using a resistance connected to signal return Pin J1-4 or Pin J1-20 (VP RTN): 0-5 k Ω = 0-100% of full-scale output voltage. Circuit is electrically connected to the output power negative terminal. See Section 3.6.
22	IP RES *	1mA current source with compliance voltage of $\sim 10.8 \text{ V}$	Current source of 1 mA for remote current programming using a resistance connected to signal return Pin J1-23 or Pin J1-25 (IP RTN): 0- 5 k Ω = 0-100% of full-scale output current. Circuit is electrically connected to the output power negative terminal. See Section 3.5.
23	IP RTN	$Z_{in} \sim 10 \text{ k}\Omega$	Current programming signal return which is to be used with Pins J1-10, J1-16 or J1-22; also must be externally connected to Pin J1-6 (COM) signal return when current programming is utilized. Circuit is electrically connected to the output power negative terminal.
24	COM †	—	Signal return. Internally connected to Pin J1-6. Circuit is electrically connected to the output power negative terminal.
25	IP RTN	$Z_{in} \sim 10 \text{ k}\Omega$	Current programming signal return which is to be used with Pins J1-10, J1-16 or J1-22; also must be externally connected to Pin J1-6 (COM) signal return when current programming is utilized. Circuit is electrically connected to the output power negative terminal.

† With the option, Remote Isolated Analog Interface control, the control signal return is isolated from the output power negative terminal. See Section 1.2.2 and Section 3.10.

* Signals not available with the option, Remote Isolated Analog Interface control.

Table 3–5. Analog Control Connector (J1), Designations and Functions

3.5 REMOTE CURRENT PROGRAMMING

Remote current programming is used for applications that require the output current to be programmed (controlled) from a remote instrument. An external resistance or external voltage source may be used as a programming device. When using remote current programming, a shielded, twisted-pair cable is recommended to prevent noise interference to programming signals.

3.5.1 REMOTE CURRENT PROGRAMMING BY RESISTANCE

The resistance-programming coefficient for output current is (100% rated output current) / 5 k Ω , with input at Pin J1-22 (IP RES) and return to Pin J1-23 (IP RTN). An internal current source, factory-set at 1 mA, from Pin J1-22 (IP RES) is utilized to drive the resistance. This produces a transfer function for output current, as follows:

$$I_{out} = R * (100\% \text{ rated output current}) / 5 \text{ k}\Omega, \text{ with } R \text{ in ohms.}$$

If multiple switches or relays are used to select resistors to program different current levels, make-before-break contacts are recommended.

Note: If an external resistance is used for remote programming, the current programming return Pin J1-23 (IP RTN), must be connected directly to, or within ± 3 V, of the circuit common, Pins J-6 and J1-24. See Figure 3-13 for connection requirements.

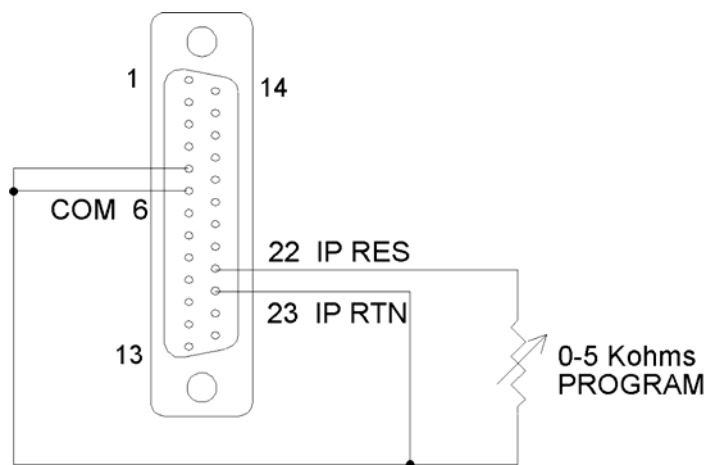

Figure 3-13. Remote Current Programming Using Resistance

3.5.2 REMOTE CURRENT PROGRAMMING BY VOLTAGE SOURCE

Two inputs are provided for remote voltage-programming of the output current: 5 VDC full-scale and 10 VDC full-scale. The DC voltage source is connected between Pin J1-10 (IP 5V) for 5 VDC source, or Pin J1-16 (IP 10V) for 10 VDC source, and the return Pin J1-23 (IP RTN).

The corresponding voltage-programming coefficients for output current are (100% rated output current) / 5 VDC, or (100% rated output current) / 10 VDC, with respect to Pin J1-23 (IP RTN). This produces transfer functions for output current, as follows:

$I_{out} = V_{dc} * (100\% \text{ rated output current}) / 5 \text{ VDC}$, with V_{dc} in volts, or

$I_{out} = V_{dc} * (100\% \text{ rated output current}) / 10 \text{ VDC}$, with V_{dc} in volts.

Note: The return Pin J1-23 (IP RTN) must be referenced directly to, or within $\pm 3 \text{ V}$, of the power supply common, Pins J1-6 and J1-24. See Figure 3-14 for connection requirements.

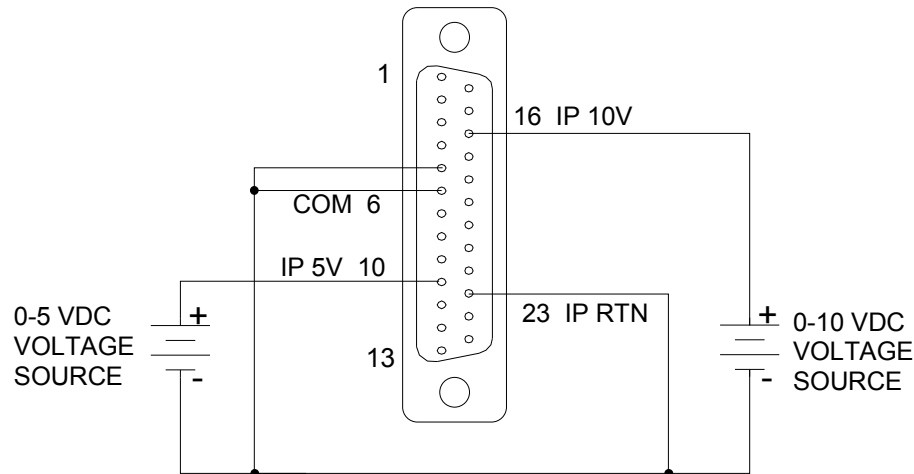

Figure 3-14. Remote Current Programming Using 0-5 VDC or 0-10 VDC Source

3.6 REMOTE VOLTAGE PROGRAMMING

Remote voltage programming configuration is used for applications that require the output voltage to be programmed (controlled) from a remote source. An external resistance or external voltage source may be used as a programming device. When using remote voltage programming, a shielded, twisted-pair, hookup wire is recommended to prevent noise interference to programming signals.

3.6.1 REMOTE VOLTAGE PROGRAMMING BY RESISTANCE

The resistance-programming coefficient for output voltage is (100% rated output voltage) / 5 k Ω , with input at Pin J1-21 (VP RES) and return to Pin J1-20 (VP RTN). An internal current source, factory-set at 1 mA, from Pin J1-21 (VP RES) is utilized to drive the resistance. This produces a transfer function for output voltage, as follows:

$V_{out} = R * (100\% \text{ rated output voltage}) / 5 \text{ k}\Omega$, with R in ohms.

Note: If an external resistance is used for remote programming, the voltage programming return Pin J1-20 (VP RTN) must be connected directly to, or within ± 3 V, of the circuit common, Pins J1-6 and J1-24. See Figure 3-15 for connection requirements.

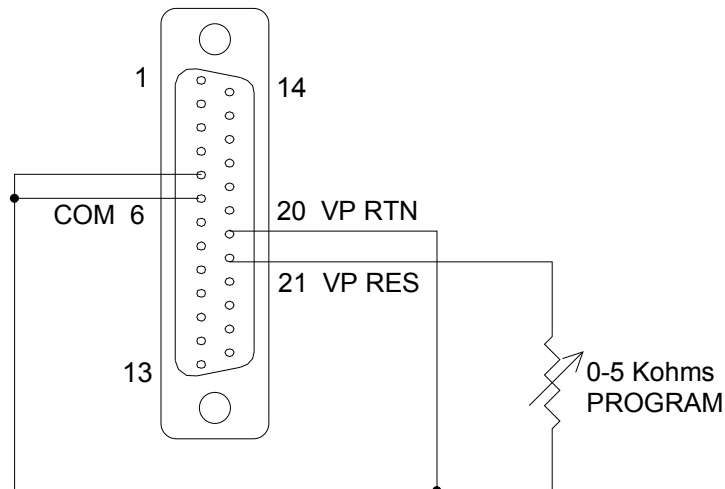

Figure 3-15. Remote Voltage Programming Using Resistance

3.6.2 REMOTE VOLTAGE PROGRAMMING BY VOLTAGE SOURCE

Two inputs are provided for remote voltage-programming of the output voltage: 5 VDC full-scale and 10 VDC full-scale. The DC voltage source is connected between Pin J1-9 (VP 5 V) for 5 VDC source, or Pin J1-15 (VP 10V) for 10 VDC source, and the return Pin J1-20 (VP RTN).

The corresponding voltage-programming coefficients for output voltage are $(100\% \text{ rated output voltage}) / 5 \text{ VDC}$, or $(100\% \text{ rated output voltage}) / 10 \text{ VDC}$, from the respective inputs with return to Pin J1-20 (VP RTN). This produces transfer functions for output voltage, as follows:

$V_{out} = V_{dc} * (100\% \text{ rated output voltage}) / 5 \text{ VDC}$, with V_{dc} in volts, or

$V_{out} = V_{dc} * (100\% \text{ rated output voltage}) / 10 \text{ VDC}$, with V_{dc} in volts.

Note: The return Pin J1-20 (VP RTN) must be referenced directly to, or within $\pm 3 \text{ V}$, of the circuit common, Pins J1-6 and J1-24. See Figure 3-16 for connection requirements.

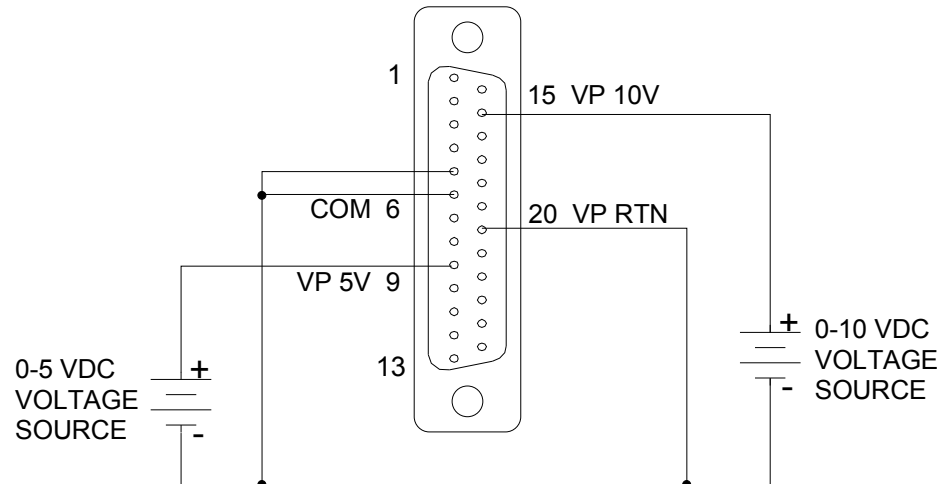

Figure 3-16. Remote Voltage Programming Using 0-5 VDC or 0-10 VDC Source

3.7 REMOTE OVERVOLTAGE PROTECTION PROGRAMMING



CAUTION!

Do not program the remote overvoltage setpoint greater than 10% above the power supply rated voltage (5.5 VDC programming voltage source), as internal power supply damage might occur (except as noted for reset).

A remote DC voltage source can be connected externally between Pins J1-3 (REM OV SET) and J1-6 (COM) to set the Overvoltage Protection (OVP) trip level. A 0.25-5.5 VDC signal equals 5-110% of rated output voltage. See Figure 3-17 for connection requirements. The Remote OVP setpoint will always take precedence over the front panel (local) trip level, even if the front panel (local) OVP trip level is set to a lower value.

Note: To reset an OVP, apply a 10.5–13.3 VDC signal to Pin J1-3 for a minimum of 7 s.

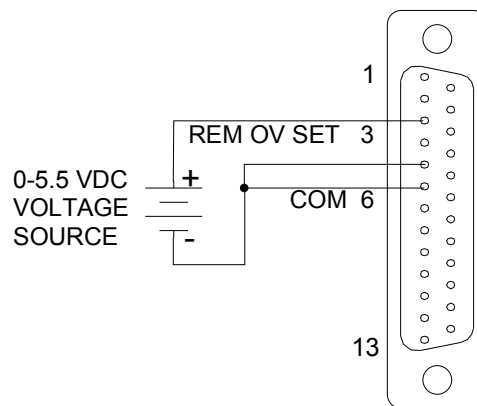

Figure 3-17. Remote Overvoltage Programming Using DC Source

3.8 REMOTE OUTPUT ON/OFF CONTROL

Remote output on/off control may be accomplished by contact closure, or through an opto-isolated interface with external voltage sources, AC/DC or TTL/CMOS.

3.8.1 REMOTE OUTPUT ON/OFF BY CONTACT CLOSURE

Application of a contact closure between Pins J1-5 and J1-6 will enable the output. See Figure 3-18 for connection requirements.

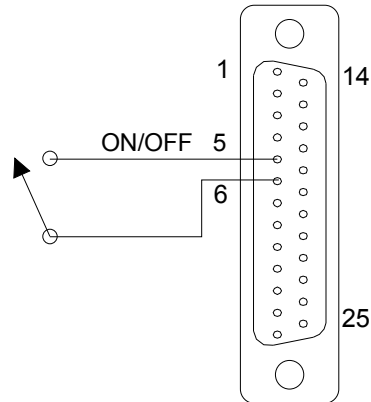

Figure 3-18. Remote Output ON/OFF Control by Contact Closure

3.8.2 REMOTE OUTPUT ON/OFF CONTROL BY EXTERNAL SOURCE

Application of AC/DC voltage between Pins J1-1 and J1-2, or TTL/CMOS voltage between Pins J1-14 and J1-2, will turn on the power supply; this interface is opto-isolated from circuit common, Pins J1-6 and J1-24. See Figure 3-19 and Figure 3-20 for connection requirements.

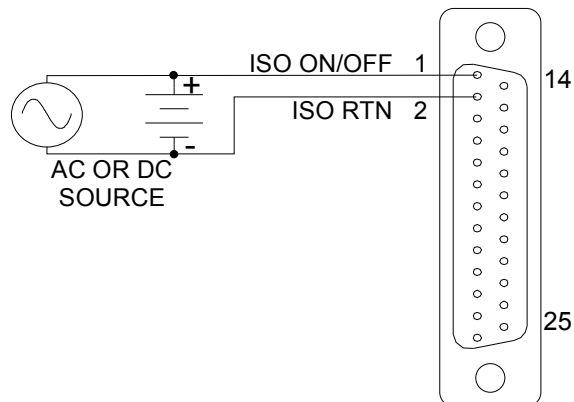

Figure 3-19. Remote Isolated Output ON/OFF Using AC or DC Source

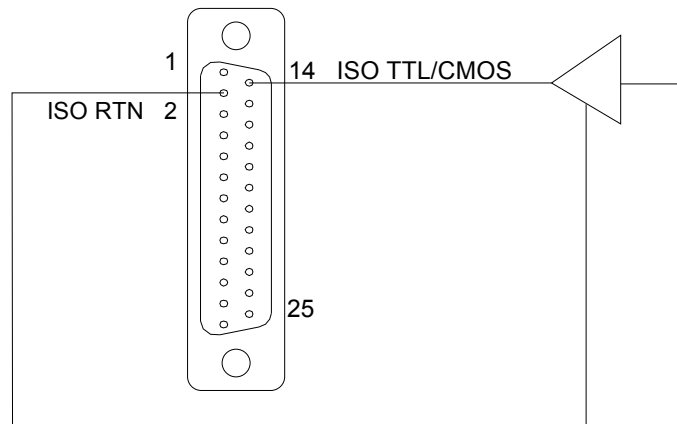

Figure 3-20. Remote Output ON/OFF Using Isolated TTL/CMOS Source

3.8.3 REMOTE SHUTDOWN (S/D)

A remote +12 VDC voltage can be connected externally between Pin J1-18 (S/D Fault) and Pin J1-24 (COM) to disable, i.e., shut down the output of the power supply; see Figure 3-21. A low-level, or opening the +12 VDC signal, will allow the unit to revert to normal operation.

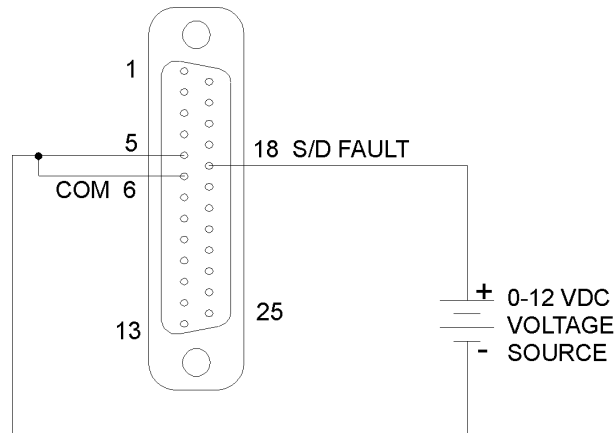

Figure 3-21. Remote Shutdown Using DC Voltage Source

3.9 REMOTE SENSING

Remote voltage sensing is recommended at all times, whether the sense leads are connected to the load or to the output terminals. Remote sensing is required to meet the performance specifications of the power supply. It is essential in applications where the load is located some distance from the power supply, or the voltage drop of the power output leads significantly interferes with load regulation.

The voltage accuracy specifications are valid only with remote sense connected. Disconnecting the remote sense leads will introduce an error, with the output voltage increasing. The error occurs because an additional resistance (PTC local resistor network in Figure 3-22) is present in the circuit of the resistor divider for voltage sensing, to provide the default local sensing of the output voltage at the output terminals. When remote sense is connected, the PTC local resistor network is short-circuited, effectively removing it from the circuit.

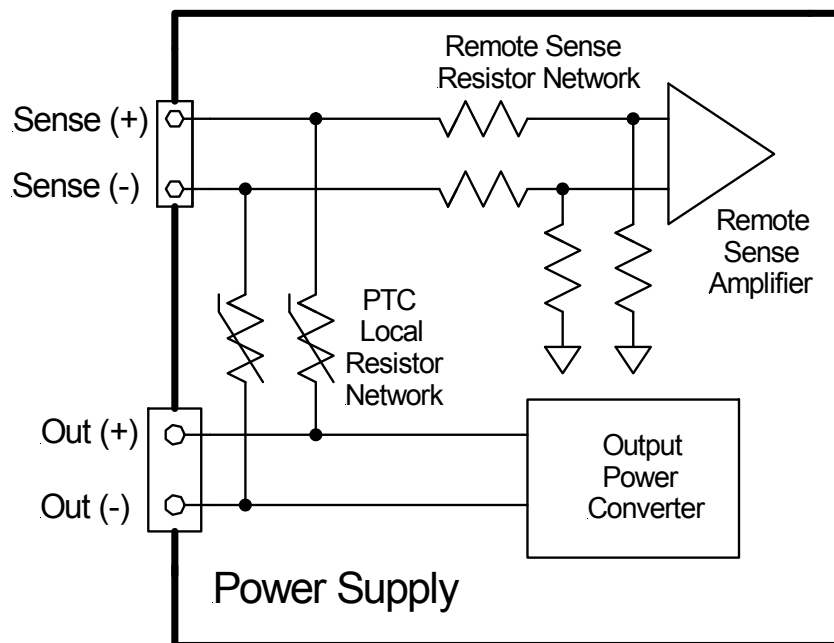



Figure 3-22. Remote Voltage Sensing Network



CAUTION!
 If the power supply is operated with load power lines disconnected and remote sense lines connected, internal power supply damage might occur, since output load current could flow through the remote sense terminals.

To use remote voltage sensing, connect the power supply as described in Figure 3-23 for the 10V-800V models, and in Figure 3-24 for the 1000V model. A shielded, twisted-pair cable is recommended to avoid potential noise interference.

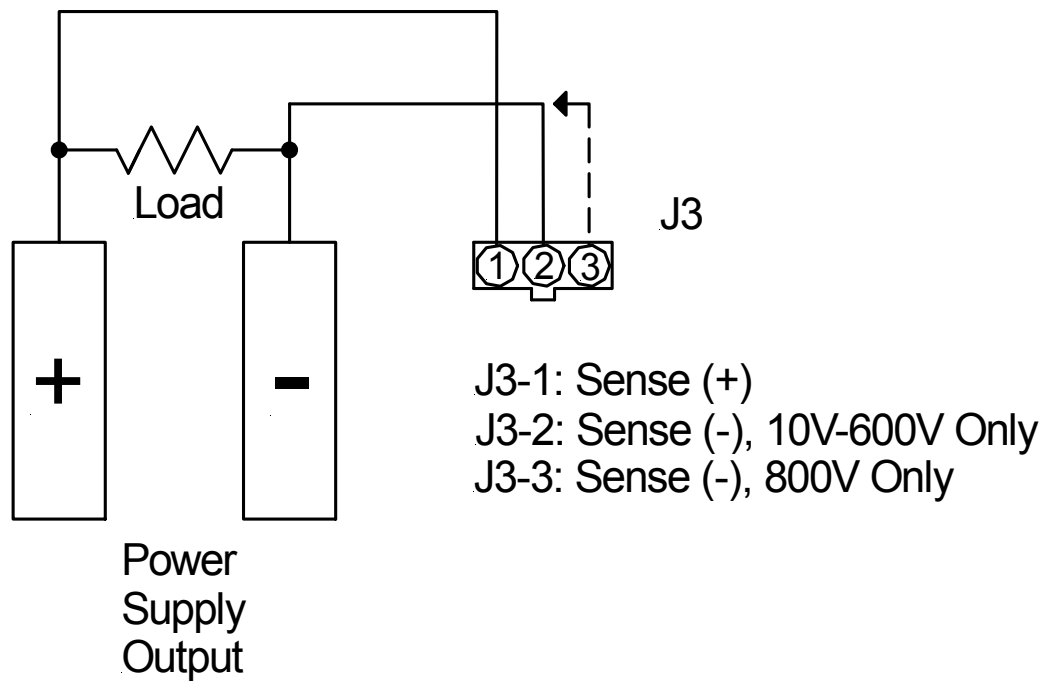

Figure 3-23. Remote Sense Connection at the Load, 10V-800V Models

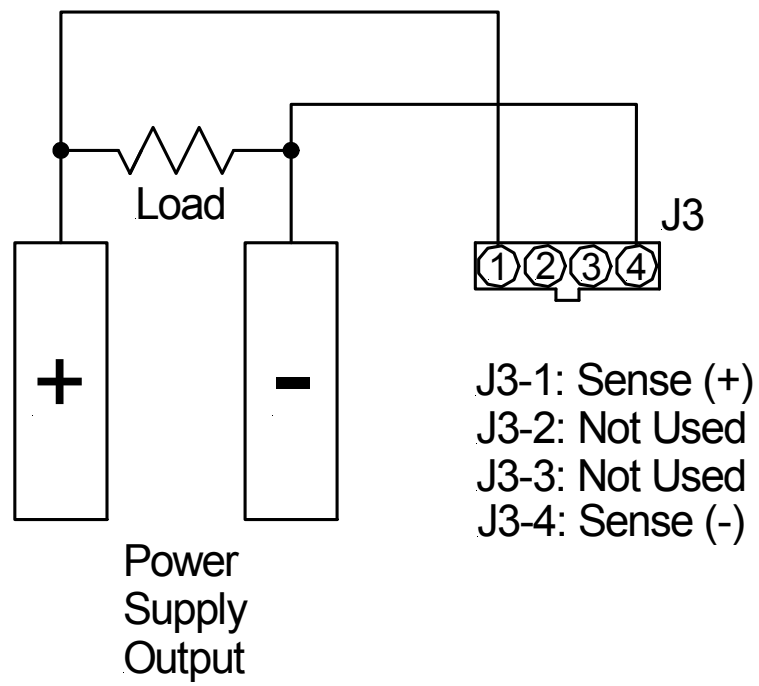

Figure 3-24. Remote Sense Connection at the Load, 1000V Model

3.10 FLOATING AND POLARIZED OUTPUT

The SGe Series supply can be set up for a Positive or Negative supply, as well as standard operation as a floating output supply.

FLOATING OUTPUT

The output terminals are normally floating from chassis ground. No extra steps or connections are required for a floating output.

POSITIVE SUPPLY SETUP

Attach the negative output terminal to the supply chassis. The output reference is now chassis ground. When the output voltage is set or programmed, the supply will output a positive potential from chassis ground.

NEGATIVE SUPPLY SETUP

Attach the Positive output terminal to the supply chassis. The output reference is now chassis ground. When the output voltage is set or programmed, the supply will output a negative potential from chassis ground.



CAUTION!

The negative output terminal may be floated up to $\pm 300\text{V}$ (PK), maximum, with respect to chassis ground. Exceeding the limit will be detected as a fault by a protective supervisory monitor and shutdown of the output will be executed; this condition will be latched, requiring reset to resume normal operation.



CAUTION!

Floating the negative output terminal subjects the internal control circuitry of the power supply to the same potential as present at the negative output terminal. In a unit with the standard Non-Isolated Analog Interface, the signals of control connector, J1, would float at the same potential as the negative output terminal. Damage might occur if the signals of the Non-Isolated Analog control connector are connected to an external ground referenced device, due to unintentional ground loop currents that this connection could generate. To correct ground loop problems, it is advised to use the optional Isolated Analog Interface in order to isolate the external signals from the internal control circuitry of the supply. Refer to Section 1.2.2 for additional information.

3.11 PARALLEL AND SERIES OPERATION

Parallel and series modes of operation are used for applications requiring more current or voltage than is available from a single power supply. To meet the requirements for greater output current or voltage, up to five supplies could be connected in parallel, or up to two supplies could be connected in series.

3.11.1 PARALLEL OPERATION

It is recommended that an SGI unit be used as the Master when configuring for parallel operation. The Slaves can be SGA, SGe, or SGI units.

With the SGI as the Master the entire system will have the same capabilities as an SGI even if the slaves are SGA or SGe units. These capabilities included Analog and Digital summing, Sequencing, Save/Recall setups, System level power setting and readouts, System level current setting and readouts, and Constant Power Mode. See SGI user's manual and SG series Programming manual for additional information on these capabilities. If using an SGA or SGe as a Master the above mentioned capabilities are not available.

Ref: Analog and Digital summing, Sequencing, Save/Recall setups, Power setting and readouts, and Constant Power Mode, these functions do not exist with an SGA or SGe master.

Ref: System level current; with an SGI as the Master the Master can know the total current available and the user simply programs and reads back the specific total system current. With an SGA or SGe as the Master the Master display and digital communications will only report current for the Master unit, not for the system level of the paralleled units. Setting the system level current will require user calculations to determine a programmed value that will result in the desired system level current. The master is programmed with the value that is the same percentage of the master current as the desired percentage of the total system current. For example, (Example 1) with two 100A units (one master and one slave) in parallel (total current = 200A) the user would program the master to 50A to achieve a system current of 100A (Example 2) with three units in parallel 50A (master), 100A (slave) and 150A (slave) (total system current = 300A) the user would program the master to 25A to achieve a system current of 150A.

In order to connect up to five power supplies in parallel, use a "Master/Slave" daisy-chain wiring configuration as follows; refer to Figure 3-25:

(There are two separate 9-pin connectors on the upper left rear panel of each power supply, marked "PAR OUT" and "PAR IN").

1. Programming, readback, and control is performed through the Master.
2. Beginning with the power supply that is to function as the Master, use an interface cable (P/N 890-453-03) to connect the PAR OUT connector on the designated Master power supply to the PAR IN connector on the second power supply (Slave 1).

3. On the second power supply (Slave 1), use another interface cable to connect the PAR OUT connector to the PAR IN connector of the third power supply (Slave 2). Continue these interconnections up to a maximum of 5 power supplies.
4. Connect the Positive output terminals of all the power supplies and the Load.
5. Connect the Negative output terminals of all the power supplies and the load.
6. Confirm that there are no shorts between the Positive and Negative output terminals.
7. Referring to Figure 3-25, connect twisted-pair sense cables as follows; ensure that all twisted-pair cables are as short as possible:

All slave units shall have twisted-pair cables from their sense terminals to their own output terminals.

For remote sense at the load, the master unit shall have a twisted-pair cable from its sense terminals to the load terminals.

For remote sense at the output terminals (local sense connection), the master unit shall have a twisted-pair cable from its own sense terminals to the output terminals of its own chassis.

Note: The OVP circuit remains active for all units in parallel operation. If the units are set to different OVP levels, the paralleled system will trip according to the lowest setting. For ease of use, adjust the OVP levels for the slaves to maximum and adjust the master OVP level to the desired setting.

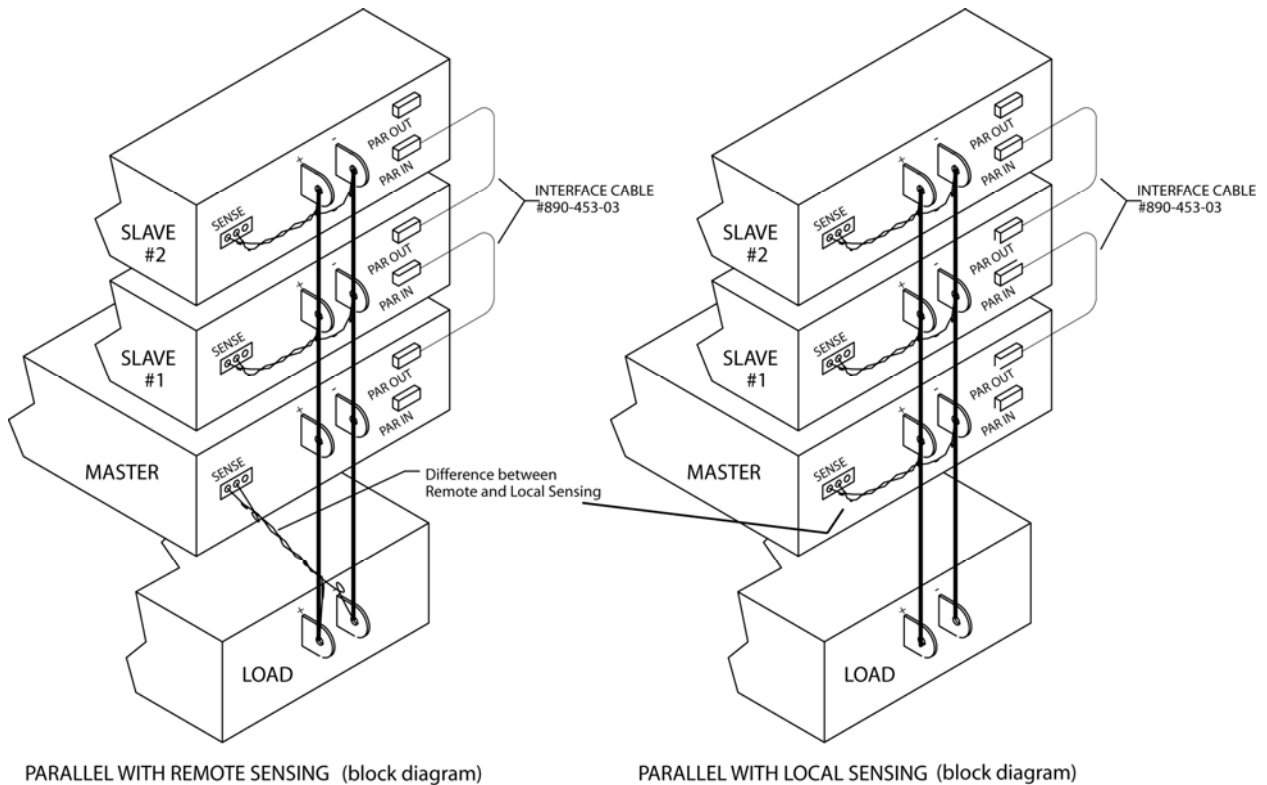

NOTE: The voltage display on the slave units will be slightly higher than the master unit. The twisted pair cable length must be as short as possible.

NOTE: The twisted pair cable length must be as short as possible.

Figure 3-25. Parallel Connection and Remote Sense

3.11.2 SERIES OPERATION

Series operation is used to obtain a higher aggregate output voltage using two units. Each supply is operated individually, and is set up as follows:

Connect the negative terminal (–) of one supply to the positive terminal (+) of the next supply; both units must be of the same model. The total voltage available is the sum of the maximum voltages of each supply. Each supply displays its own output voltage, and the load voltage is the sum of each front panel display.



CAUTION!

Under no condition should the negative (–) output terminal of any power supply exceed 300 V to chassis (earth) ground. This is limited by the isolation and creepage/clearance distances internal to the power supply construction. If a higher output voltage range is required, contact the factory for availability.

Note:

1. The maximum allowable current for a series string of power supplies is the rated output current of a single supply of the string.
2. Remote sensing **at the load** should **not** be used during series operation. Each power supply should have its remote sense leads connected to its own output terminals.
3. An anti-parallel diode (power diode capable of the maximum current of the series group, connected across the output, but reverse biased) is recommended to protect against sinking current into a supply should one supply be ON while another other is OFF, as shown in Figure 3-26. Diode D2 shown in the figure is optional, if the load has stored energy such as a battery (Refer to Section 2.6.1).

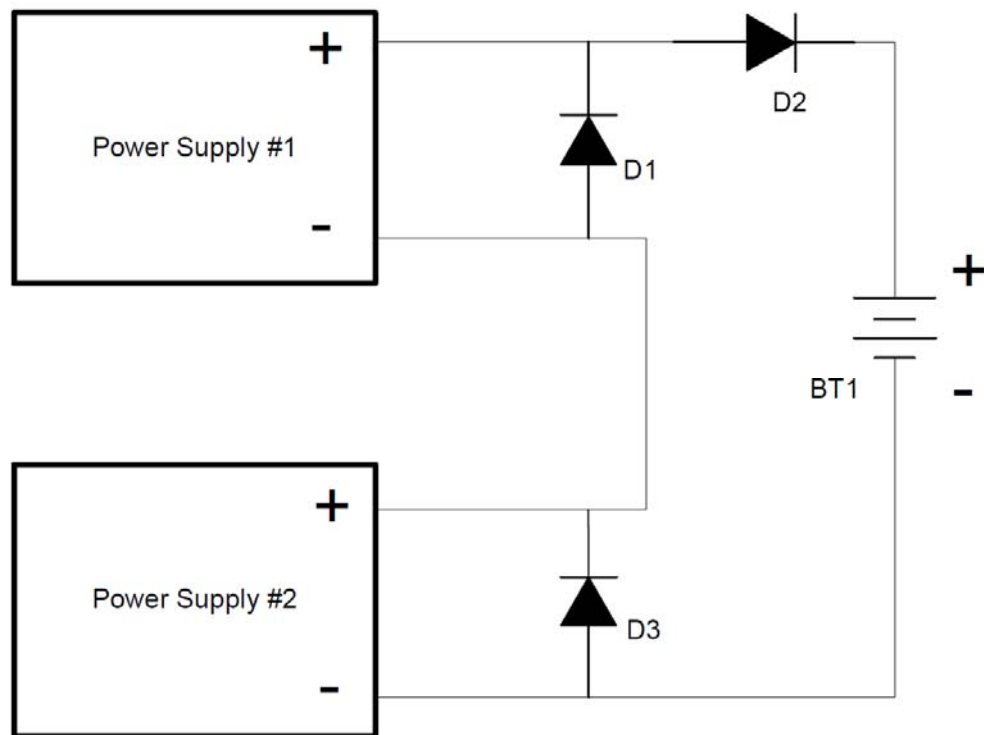

Figure 3-26. Series Connection with Anti-Parallel Diodes

SECTION 4

CALIBRATION AND VERIFICATION

4.1 INTRODUCTION

This section provides calibration and verification procedures for the SGe Series power supplies and the Remote Isolated Analog Interface control (option). Refer to the SG Programming Manual for calibration of display readback and remote digital programming option.

4.1.1 CALIBRATION AND VERIFICATION CYCLE

Annual calibration and verification is recommended. Calibrate only as needed.

4.1.2 PREPARATION



WARNING!

Hazardous voltages exist at the rear of the supply. Care must be taken to avoid contact with the AC input and DC output terminals. Only authorized personnel should perform this procedure.

Only technically trained personnel, who understand the operation of the power supply and are capable taking accurate readings should perform calibration. The calibration procedures require two digital multimeters and a precision shunt for measurement of voltage and current. To set up for the calibration procedures, perform the following initial steps:

1. Disconnect AC mains power.
2. Connect a precision current shunt, that is suitably derated, across the output of the power supply; a fan might be required to cool the shunt. Connect remote

sense leads, and ensure that the digital voltmeter that measures output voltage is connected across the sense leads.

4.2 CALIBRATION AND VERIFICATION PROCEDURES



WARNING!

Hazardous voltages might be present on the output, even after it is disabled, due to stored capacitive charge. Disconnect the AC mains input, and allow 5 minutes to drain the output capacitive charge to safe levels, before connecting or removing output wiring.

All calibration potentiometers are on circuit board assemblies located at the front of the chassis, and adjustment of the potentiometers is made from the top of the chassis. Refer to Figure 4-1 for the physical location of the potentiometers. Some of the models will require partial removal of the top cover of the chassis to gain access to the potentiometers, dependent on the type of chassis.

The 6U-chassis units and earlier 3U-chassis units have access holes in the top cover that allow adjustment of the calibration potentiometers without removing the top cover. However, if the Ethernet option is installed, some of the potentiometers are covered by a ribbon-cable. To adjust those potentiometers, the cover should be partially removed, and slid towards the rear of the chassis just enough to expose the location of the potentiometers, but with the cover still on top of the chassis. The ribbon-cable should then be carefully moved sufficiently to expose the adjustment screws of the potentiometers.

The latest 3U-chassis units do not have access holes in the top cover, and the top cover must be partially removed to perform calibration. The cover should be slid towards the rear of the chassis just enough to expose the potentiometers, but with the cover still on top of the chassis. If the Ethernet option is installed, a ribbon-cable must be moved, as described above for the 6U-chassis.

When a unit is configured with the Remote Isolated Analog Interface option, calibration must be first performed on that option (refer to Section 4.3), before the standard calibration and verification procedures of Section 4.2 are performed.

4.2.1 CONSTANT-CURRENT MODE

1. Setup the SGe Series unit to operate with remote current programming using an external 0-5 VDC voltage-source, as shown in Figure 3-14 in Section 3.5.2. Ensure that Pins J1-5 and J1-6 are jumpered to enable the output.
2. Connect a precision current shunt across the output of the power supply, and attach a precision meter across the shunt Kelvin terminals. (see Section 4.1.2).
3. Attach a precision meter in parallel with the current programming voltage-source.
4. Set the current programming source to $0.0\text{ V} \pm 1\text{ mV}$.
5. Program the output voltage, with the front panel control or remote interface, to 100% of rated output voltage
6. Apply AC power, turn the unit on, and press the "Output On" button to enable the output (see Section 3.1.13.1.1).
7. Set the current programming source to $5.0\text{ V} \pm 1\text{ mV}$.
8. Verify that the unit produces $100\% \pm 0.8\%$ of rated output current. If necessary, adjust R69 for 100% of rated output current through the shunt.
9. Set the current programming source for $0.5\text{ V} \pm 1\text{ mV}$.
10. Verify that the unit produces $10\% \pm 0.8\%$ of rated output current. If necessary, adjust R55 for 10% of rated output current through the shunt.
11. Repeat the steps above as required to obtain the required accuracy.

4.2.2 CONSTANT-VOLTAGE MODE

1. Disconnect the AC mains power to the unit. Remove the current shunt from the output and verify that there is no load attached.
2. Remove the precision meter leads from the current shunt and apply them across the output terminals.
3. Setup the SGe Series unit to operate with remote voltage programming using an external 0-5 VDC voltage-source, as shown in Figure 3-16 in Section 3.6.2. Ensure that Pins J1-5 and J1-6 are jumpered to enable the output.

4. Program the output current, with the front panel control or remote interface, to 100% of rated output current.
5. Apply AC power, turn the unit on, and press "Output On" button to enable the output (see Section 3.1.1).
6. Set the voltage programming source to 5.0 V \pm 1 m V.
7. Verify that the unit produces 100% \pm 0.25% of rated output voltage. If necessary adjust R74 for 100% of rated output voltage.
8. Set the voltage programming source to 0.5 V \pm 1 mV.
9. Verify that the unit produces 10% \pm 0.25% of rated output voltage. If necessary adjust R90 for 10% of rated output voltage.
10. Repeat the steps above as required to obtain the required accuracy.
11. Remove all connections to the remote analog control connector (J1), except the jumper between Pins J1-5 and J1-6; ensure that they are jumpered to enable the output, and allow front panel control.

4.2.3 RESISTIVE-CONTROL PROGRAMMING CURRENT SOURCES (Standard, Non-Isolated Analog Interface Control)

1. Disconnect the AC mains power to the unit.
2. Connect a precision current shunt across the output of the power supply, and attach a precision meter across the shunt Kelvin terminals. (see Section 4.1.2).
3. Setup the SGe Series unit to operate with remote current programming using resistance by connecting a 5 k Ω (0.1% or better tolerance) resistor, as shown in Figure 3-13 in Section 3.5.1. Ensure that Pins J1-5 and J1-6 are jumpered to enable the output.
4. Attach a precision meter across the shunt Kelvin terminals.
5. Apply AC power, turn the unit on, and press "Output On" button to enable the output (see Section 3.1.1).
6. Adjust R33 so that the measured output current equals 100% rated output current.
7. Disable AC power to the unit.
8. Setup the SGe Series unit to operate with remote voltage programming using resistance by connecting a 5 k Ω (0.1% or better tolerance) resistor, as shown in Figure 3-15 in Section 3.6.1. Ensure that Pins J1-5 and J1-6 are jumpered to enable the output.

9. Apply AC power, turn the unit on, and press “Output On” button to enable the output (see Section 3.1.1).
10. Adjust R35 so that the measured output voltage equals 100% rated output voltage.
11. Turn off AC power, and remove all connections to the remote analog control connector (J1), except the jumper between Pins J1-5 and J1-6; ensure that they are jumpered to enable the output, and allow front panel control.

4.3 REMOTE ISOLATED ANALOG INTERFACE (OPTION) CALIBRATION AND VERIFICATION PROCEDURES



CAUTION!

Hazardous voltages may be present on the output, even after it is disabled, due to stored capacitive charge. Disconnect the mains AC input, and allow 5 minutes to drain the output capacitive charge to safe levels before connecting or removing output wiring.

4.3.1 CONSTANT-CURRENT MODE

1. Disconnect AC mains power to the unit. Setup the SGe Series unit to operate with remote current programming using an external 0-5 VDC voltage source, as shown in Figure 3-14 in Section 3.5.2. Ensure that Pins J1-5 and J1-6 are jumpered to enable the output.
2. Connect a precision current shunt across the output of the power supply, and attach a precision meter across the shunt Kelvin terminals. (see Section 4.1.2).
3. Attach a precision meter in parallel with the current programming voltage-source.
4. Set the current programming source to $0.0\text{ V} \pm 1\text{ mV}$.
5. Program the output voltage, with the front panel control or remote interface, to 100% of rated output voltage.
6. Apply AC power, turn the unit on, and press “Output On” button to enable the output (see Section 3.1.1).
7. Set the current programming source to $5.0\text{ V} \pm 1\text{ mV}$.

8. Verify that the unit produces 100% $\pm 0.8\%$ of rated output current. If necessary, adjust R33 for 100% of rated output current through the shunt.
9. Set the current programming source for 0.5 V ± 1 mV.
10. Verify that the unit produces 10% $\pm 0.8\%$ of rated output current. If necessary, adjust R47 for 10% of rated output current through the shunt.
11. Repeat the steps above as needed to obtain the required accuracy.

4.3.2 CONSTANT-VOLTAGE MODE

1. Disconnect AC mains power to the unit. Remove the current shunt from the output and verify that there is no load attached.
2. Remove the precision meter leads from the current shunt and apply them across the output terminals.
3. Setup the SGe Series unit to operate with remote voltage programming using an external 0-5 VDC voltage-source, as shown in Figure 3-16 in Section 3.6.2. Ensure that Pins J1-5 and J1-6 are jumpered to enable the output.
4. Program the output current, with the front panel control or remote interface, to 100% of rated output current.
5. Apply AC power, turn the unit on, and press "Output On" button to enable the output (see Section 3.1.1).
6. Set the voltage programming source to 5.0 V ± 1 mV.
7. Verify that the unit produces 100% $\pm 0.25\%$ of rated output voltage. If necessary adjust R39 for 100% of rated output voltage.
8. Set the voltage programming source to 0.5 V ± 1 mV.
9. Verify that the unit produces 10% $\pm 0.25\%$ of rated output voltage. If necessary adjust R35 for 10% of rated output voltage.
10. Repeat the steps above as needed to obtain the required accuracy.
11. Remove all connections to the remote analog control connector (J1), except the jumper between Pins J1-5 and J1-6; ensure that they are jumpered to enable the output, and allow front panel control.

<p>Standard Calibration Adjustments</p> <p>R35 = VPRES (1 mA) Adjust R33 = IPRES (1 mA) Adjust R74 = Full-Scale Voltage Adjust R90 = Zero Voltage Adjust R69 = Full-Scale Current Adjust R55 = Zero Current Adjust</p>	<p>Isolated Analog (Option) Calibration Adjustments</p> <p>R39 = Full-Scale Voltage Adjust R35 = Zero Voltage Adjust R33 = Full-Scale Current Adjust R47 = Zero Current Adjust</p>									
<p>Factory Use Only</p> <table> <tr> <td>R37</td> <td>R45</td> <td>R46</td> </tr> <tr> <td>R54</td> <td>R71</td> <td>R73</td> </tr> <tr> <td>R82</td> <td>R86</td> <td>R104</td> </tr> </table>		R37	R45	R46	R54	R71	R73	R82	R86	R104
R37	R45	R46								
R54	R71	R73								
R82	R86	R104								

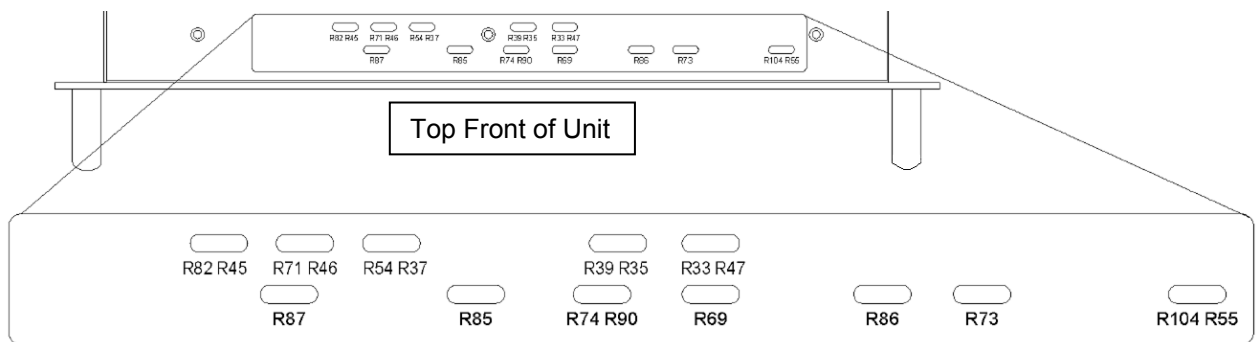

Top view of potentiometers as located on internal circuit boards.

Figure 4-1. Potentiometer Locations

This page intentionally left blank.

SECTION 5 MAINTENANCE

5.1 INTRODUCTION

This chapter contains preventive maintenance information for the SGe Series power supplies.



WARNING!

All maintenance that requires removal of the cover of the unit should only be done by properly trained and qualified personnel. Hazardous voltages exist inside the unit. Disconnect the supply from the AC mains input before performing any maintenance. Service, fuse verification, and connecting of wiring to the chassis must be accomplished at least 5 *minutes* after AC input power has been removed with an external disconnect switch. Do not touch any circuits and/or terminals that are energized.

5.2 PREVENTIVE MAINTENANCE



WARNING!

The OFF position of the front panel power switch does not remove AC input from internal circuits or input terminal blocks. Disconnect external AC input before servicing unit.



CAUTION!

For safe and continued operation of the SGe Series, always operate the unit in a temperature and humidity controlled, indoor area. Exposure to conductive contaminants or corrosive compounds/gases that could be ingested into the chassis could result in internal damage. Keep the rear and sides of the unit free of obstructions to ensure proper ventilation.

No routine maintenance on the SGe Series is required, aside from periodic cleaning of the unit and inspection, as required by the environmental operating conditions:

- Once a unit is removed from service, vacuum all air vents, including the front panel grill.
- Clean the exterior with a mild solution of detergent and water. Apply the solution onto a soft cloth, not directly to the surface of the unit. To prevent damage to materials, do not use aromatic hydrocarbons or chlorinated solvents for cleaning.
- Check external connections for integrity of insulation, loose contacts, and proper torque.
- If there is any evidence of short-circuits or arcing, overheating, or corrosion, contact the factory for recommended service.

5.3 FUSES

There are no user replaceable components in the power supply. Internal fuses are listed in Table 4.1. Fuses are sized for fault isolation, and, an open fuse might indicate that a circuit component has been damaged. Contact the factory for further assistance..



CAUTION!

To reduce the risk of fire or electrical shock, replace fuses only with the same type and rating.

Assembly	Reference	Rating	Manufacturer Part No.
Bias Supply PWA	F1, F2, F3	5 A, 600 V	Littelfuse, KLK-5
Power Module Converter Control PWA	F1, F2, F3	30 A, 600 V	Littelfuse, KLK-30

Table 4.1. Fuse Ratings

This page intentionally left blank.

INDEX

A

- AC Input Connector, 3U, 2-10
 - Screw Torque, 2-10
- Agency Approvals, 1-3
- Analog Control Connector (J1), 3-14
 - Designations and Functions, 3-17
 - Isolated Analog Voltage, 3-14
 - Return Connection, 3-14

C

- Calibration and Verification
 - Remote Isolated Analog (Option), 4-5
- Calibration and Verification, 4-1, 4-2
 - Constant-Current Mode, 4-3
 - Constant-Voltage Mode, 4-3
 - Resistive-Control Current Sources, 4-4
- Calibration and Verification
 - Isolated Analog Constant-Current Mode, 4-5
- Calibration and Verification
 - Isolated Analog Constant-Voltage Mode, 4-6
- Constant-Current Mode, 3-12
 - Calibration and Verification, 4-3
 - Operation, 3-12
- Constant-Voltage Mode, 3-11
 - Calibration and Verification, 4-3
 - Operation, 3-11
- Contents of Shipment, 2-1
- Controls and Indicators, 3-1
 - Analog Control (J1), 3-14
 - Front Panel ON/OFF Switch, 3-2
 - OVP Adjust Potentiometer, 3-2
 - OVP Set/Reset Button, 3-2

E

- Electrical Characteristics, 1-3
- Environmental Characteristics, 1-3

F

- Flexible Cables, 2-11
- Floating Negative Terminal, 2-8
- Front Panel Drawing, 3-1
- Fuses, 5-3

I

- Initial Setup, 3-10
- Input Overcurrent Protection, 2-8
 - Circuit Breaker/Fuse Rating, 2-8
- Input/Output Connections, 2-8
 - Connectors, 2-9
 - Input Overcurrent Protection, 2-8
 - Input Terminal Connections, 2-10
 - Lugs, 2-10
 - Maximum AC Current Ratings, 2-9
 - Output Terminal Connections, 2-10
 - Safety Disconnect Device, 2-8
 - Safety Ground Wire, 2-8
 - Sense Connector Tools, 2-10
- Inspection, 2-1
- Installation Drawings, 2-15

L

- Loads, 2-14
 - Inductive, 2-14
 - Stored-Energy, 2-14
- Location, 2-2
 - Protected Environment, 2-2

- Ventilation, 2-2
- M
- Maintenance, 5-1
 - Cleaning/Inspection, 5-2
 - Fuses, 5-3
 - Preventive, 5-1
- Maximum AC Current Ratings, 2-9
- Model Number Decoding, 1-3
- Mounting, 2-2
 - 6U Rack Removal, 2-7
 - Rack Mounting, 2-3
- O
- Operation, 3-1
 - Constant-Current Mode, 3-12
 - Constant-Voltage Mode, 3-11
 - Front Panel, 3-10
 - Initial Setup, 3-10
 - Parallel, 3-29
 - Power-Up State, 3-10
 - Remote Current Programming, 3-18
 - Remote Output On/Off Control, 3-23
 - Remote Overvoltage Protection
 - Programming, 3-22
 - Remote OVP Reset*, 3-22
 - Remote Sensing, 3-25
 - Remote Shutdown, 3-24
 - Remote Voltage Programming, 3-20
 - Series, 3-31
- Outline Drawings, 2-15
- Output Isolation
 - Negative Output Terminal, 1-6
 - Output Float Voltage, 1-6
- Overvoltage Protection, 3-13
- P
- Parallel Operation, 3-29
 - Master/Slave Connections, 3-29
- Physical Characteristics, 1-8
- Polarized Output, 3-28
- Protective Covers Assembly, 2-30, 4-8
- R
- Rack Mounting, 2-3
- Rear Panel Drawings, 2-15
- Remote Current Programming, 3-18
 - Resistance Control, 3-18
 - Voltage Source Control, 3-19
- Remote Isolated Analog Interface Control, 3-14
- Remote Output On/Off Control, 3-23
 - Contact Closure Control, 3-23
 - External Source Control, 3-23
 - Shutdown (S/D), 3-24
- Remote Overvoltage Protection
 - Programming, 3-22
- Remote Sensing, 1-5, 3-25
 - Error with Disconnected Sense, 3-25
- Remote Shutdown, 3-24
- Remote Voltage Programming, 3-20
 - Resistance Control, 3-20
 - Voltage Source Control, 3-21
- Ripple/Noise, 1-7
- S
- Safety Disconnect Device, 2-8
- Safety Ground Wire, 2-8
- Series Operation, 3-31
- Shaft Lock, 3-9
- Specifications, 1-3
 - Electrical Characteristics, 1-3
 - Environmental Characteristics, 1-3
 - Output Isolation, 1-6
 - Parallel Operation, 1-6
 - Physical Characteristics, 1-8
 - Rated Current, 1-7
 - Rated Output Power, 1-4
 - Rated Voltage, 1-7
 - Remote Analog Interface, 1-5
 - Remote Sensing, 1-5
 - Ripple/Noise, 1-7
 - Series Operation, 1-6
- W
- Wire Selection, 2-11
 - Current Ratings, 2-11
 - Flexible Cable, 2-11
 - Voltage Drop, 2-14
 - Wire Size, 2-11

This page intentionally left blank.