



Thank you for purchasing the PR300. This manual describes the installation and wiring procedures of the PR300. The electronic manuals are also provided on the accompanying CD in addition to this manual. Read them along with this manual. To ensure correct use, be sure to read the PR300 Power and Energy Meter User's Manual (IM 77C01E01-01E) thoroughly before beginning operation.

Printed manuals (Electronic manuals [PDF files] are also provided on the accompanying CD.)

Model PR300 Power and Energy Meter Startup Manual <Installation> :  
IM 77C01E01-02E (This manual)

Model PR300 Power and Energy Meter Startup Manual <Initial Setup Operations> :  
IM 77C01E01-03E

Electronic manuals (PDF files)

Model PR300 Power and Energy Meter User's Manual :  
IM 77C01E01-01E

Model PR300 Power and Energy Meter Communication Interface User's Manual :  
IM 77C01E01-10E

Please keep this manual for future reference.



IM 77C01E01-02E  
1st Edition: Feb. 2006

### Checking the Package

Verify the package as explained below before starting to use the product. Should the delivered product be wrong or the package be missing any item, contact the vendor from which you purchased the product.

#### Checking the Model and Suffix Codes

The PR300 bears a nameplate. Confirm that "MODEL" and "SUFFIX" (suffix codes) shown on the nameplate agree with those of the product ordered.

Model	Suffix Codes	Description
PR300	-□ □ □ □ -6 □ -0	Power and Energy Meter
Phase and wire system	-3	Universal three-phase three-wire system (single-phase two-wire, single-phase three-wire, and three-phase three-wire systems)
	-4	Universal three-phase four-wire system (single-phase two-wire, single-phase three-wire, three-phase three-wire, and three-phase four-wire systems)
	-5	Three-phase four-wire system (2.5 element) <sup>*1</sup>
Input voltage/ input current	1	Universal voltage input <sup>*2</sup> (150 V, 300 V, 600 V) / 1 A
	2	Universal voltage input <sup>*2</sup> (150 V, 300 V, 600 V) / 5 A
Additional input and output function	0	1 digital input
	1	1 digital input, 1 analog output
	2	1 digital input, 1 pulse output
	3	1 digital input, 1 analog output, 1 pulse output
Communication function	0	RS-485 communication
	3	RS-485 communication, Ethernet communication <sup>*3</sup>
Optional measuring function	0	None
	3	Demand measurement (1 demand alarm output)
Power supply	-6	100-240 V AC ±10% (50/60 Hz) or 130-300 V DC ±15%
Phase indication format	A	A, B, and C indications
	R	R, S, and T indications
	-0	Always 0

<sup>\*1</sup> Can be used only when the voltage is a state of equilibrium.  
<sup>\*2</sup> Set the voltage range (150 V, 300 V, or 600 V) according to the rated input voltage to be measured.  
<sup>\*3</sup> For Ethernet communication, the RS-485 communication interface is exclusively for the Ethernet-serial gateway function.

Yokogawa Electric Corporation  
Network Solutions Business Division  
2-9-32, Naka-cho Musashino-shi, Tokyo 180-8750 Japan  
Phone: +81-422-52-7179 Facsimile: +81-422-52-6619

## 1. Installation



### NOTE

- Do not install the PR300 in the following types of environments, as they may cause the product to malfunction or fail.  
**Avoid sites:**  
exposed to significant shock or vibration; where corrosive gases are present; where large amounts of dust are present; exposed to water; exposed to direct sunlight; outside; at altitudes above 2000 m.
- The PR300 mounting position is for vertical panels only.**

### 1.1 Installation with the ANSI 4-inch Round Form

The PR300 can be installed so that it handles ANSI 4-inch round form or JIS 110-square instruments panel cutouts by attaching the "JIS/ANSI-mounting kit" accessory.

#### 1.1.1 External Dimensions

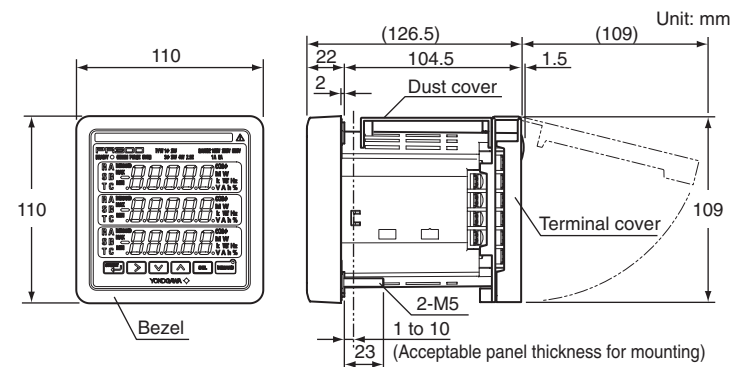

#### 1.1.2 Panel Cutout Dimensions

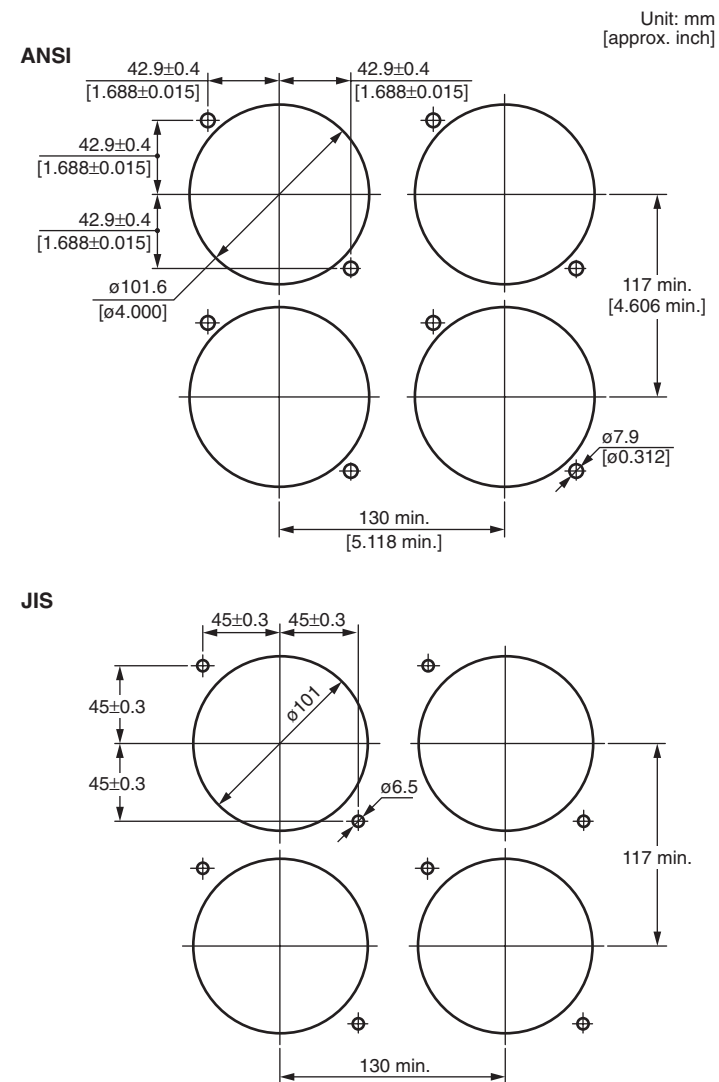

### 1.1.3 Mounting Method

1 Set the direction of the panel-mounting bracket.

The diagram below shows the front of the bracket (the side into which the panel-mounting bolt is inserted). Rotating the bracket 90° makes the bracket compatible with either ANSI or JIS panel cutouts. Set the bracket to either the ANSI or JIS mark according to which type of panel you are installing, as shown in the diagram.

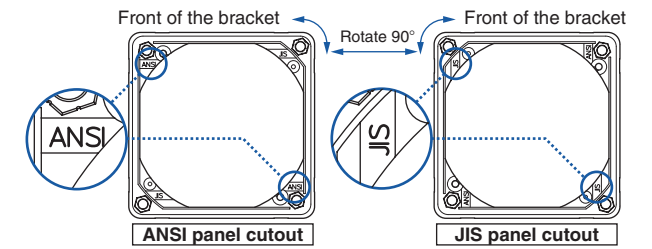

2 Insert two panel-mounting bolts into the front of the panel-mounting bracket as shown in the diagram.

3 Fix the panel-mounting bracket securely to the back of the PR300 with two bracket-fixing screws as shown in the diagram.

4 Attach the bezel from the front of the PR300.

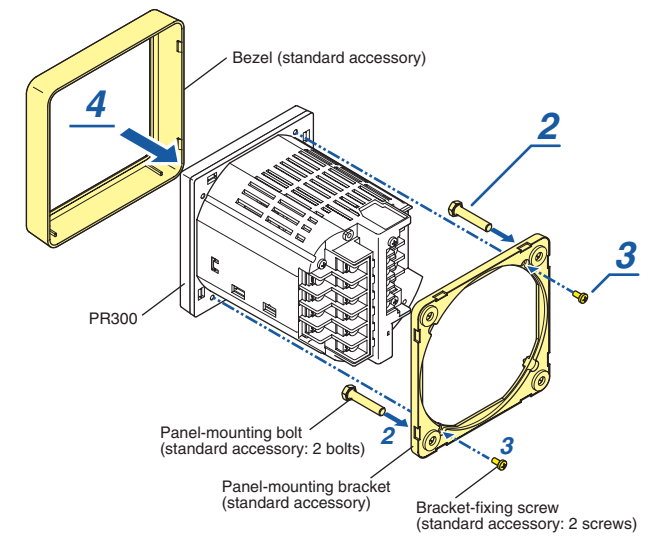

5 Insert the PR300 from its rear through the mounting cutout in the panel as shown in the diagram.

6 Secure the PR300's panel-mounting bolts by tightening them with the washers and nuts.

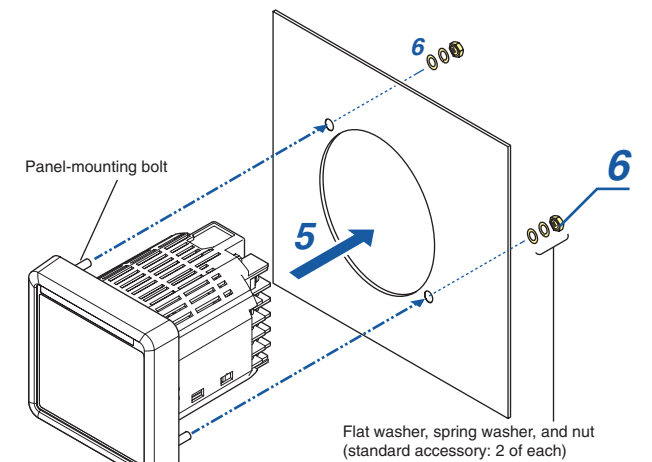

#### Serial Number (NO.)

Also inform this number shown in "NO." on the nameplate when contacting the vendor from which you purchased the PR300.

#### Checking the Accessories

**JIS/ANSI-mounting kit**

- Bezel (1)
- Panel-mounting bracket (1)
- Panel-mounting bolts (2)
- Bracket-fixing screws (2)
- Nuts (2)
- Flat washers (2)
- Spring washers (2)

**DIN-mounting brackets** (for DIN 96-square instrument panel mounting)

**Dust cover** (with 1 fixing screw)

**Terminal cover** (with 3 fixing screws)

**Shorting bar** (for RS-485 communication termination)

**Tag number labels**

**Startup manuals** (Installation/Initial Setup Operations)

**Manuals for the PR300** (This CD contains all manuals related to the PR300.)

## 1.2 Installation with the DIN 96-square Instrument Size

### 1.2.1 External Dimensions

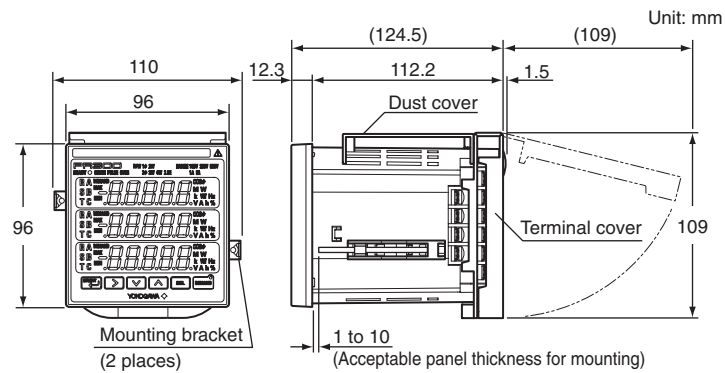

### 1.2.2 Panel Cutout Dimensions

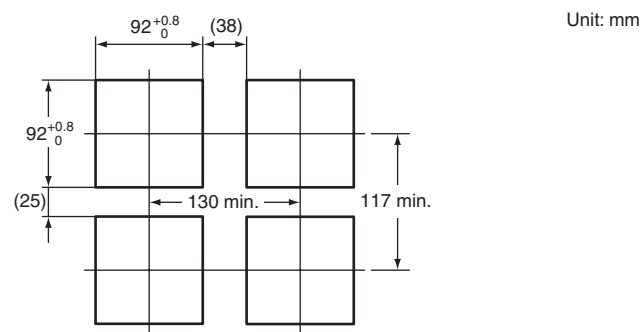

### 1.2.3 Mounting Method

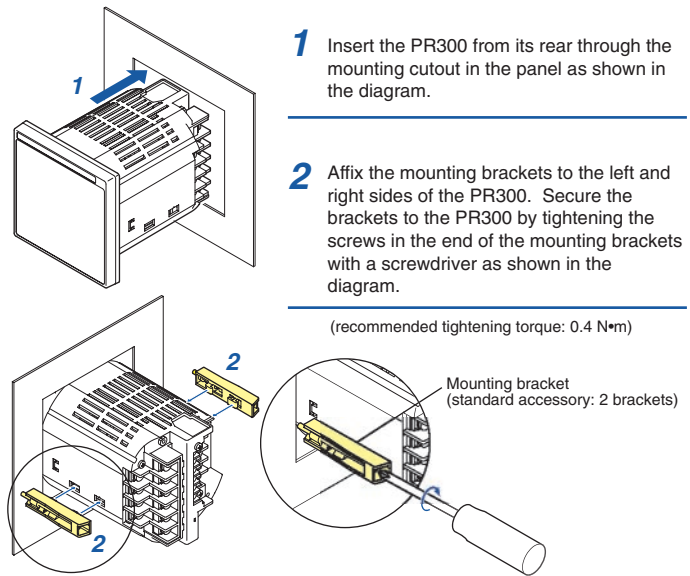

## 2. Wiring

### CAUTION

- As there is a danger of electric shock, turn off the power supply and check that the cables to be connected are not conducting electricity before carrying out the wiring procedure.
- For safety, be sure to install a circuit breaker switch that conforms to IEC 60947 near the PR300 so as to be operated easily, and clearly indicate that the device is used to de-energize the PR300.
- The wiring procedure for the PR300 should be carried out by a qualified person (an electrician etc.) with knowledge of electrical matters and who has actual experience.
- If the voltage is below 600 V AC, it is possible to connect the PR300 directly without using a voltage transformer (VT) and if the current is below 5 A AC, it is possible to do so without using a current transformer (CT). However, in order to use the PR300 safely, the use of a VT and CT is recommended.

- Check the following before turning on the power, Using the PR300 beyond the stated specifications may cause it to heat up and burn out.

- Check that the power supply voltage, input voltage, and input current values to be applied to the PR300 agree with its specifications.
- Check that the external wiring is connected to the terminals in accordance with the specifications.

- Do not touch the screws in locations (a) to (f) shown in the wiring diagrams. They are an essential part of the structure of the PR300. Loosening or tightening them may result in a malfunction or failure of the PR300.

- Be sure to attach the terminal cover to prevent electric shock (refer to Chapter 3).



### NOTE

#### When attaching the terminal cover

- Since the terminal cover of PR300 has the structure to prevent electric shock, the terminal cover cannot be attached after completing all wiring. Refer to Chapter 3 "Attaching the Dust Cover and Terminal Cover" before wiring.

Carry out the wiring referring to the diagrams in Sections 2.1 to 2.6. The wiring for voltage input, current input, and power supply is M4 screw terminal connection. For other wiring it is M3 screw terminal connection. The connector for connecting to the Ethernet is RJ45. Use strand wires for the wiring. Wiring cables with a nominal cross-sectional area of 1.25 mm<sup>2</sup> or thicker are recommended for voltage/current input and power supply; cables with a nominal cross-sectional area of 0.5 mm<sup>2</sup> or thicker are recommended for other signals. Durable good-contact ring tongue crimping terminals are recommended to use.

#### Ring tongue terminal

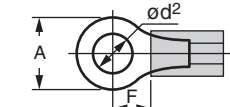

Applicable terminals	∅d <sup>2</sup> (mm)	A (mm)	F (mm)	B (mm)
M4	4.4 max.	7.0 max.	7.8 max.	—
M3	3.3 max.	5.8 max.	6.7 max.	4.7 max.

#### Spade tongue terminal

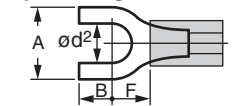

Applicable terminals	Recommended tightening torque	Applicable wire size
M4	1.2 N·m	1.04 to 2.63 mm <sup>2</sup>
M3	0.6 N·m	0.25 to 1.65 mm <sup>2</sup>

### 2.1 Single-phase two-wire system

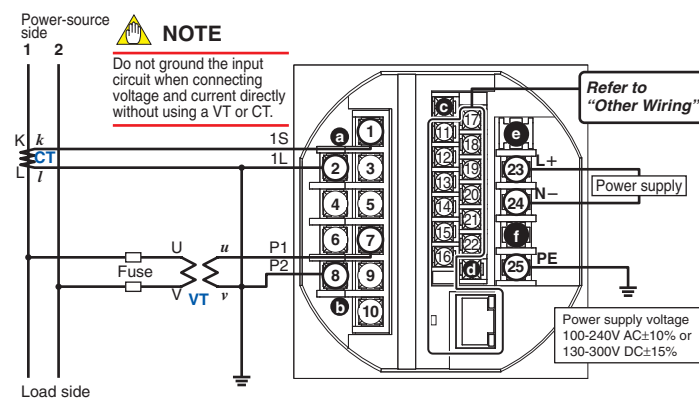

### 2.2 Single-phase three-wire system

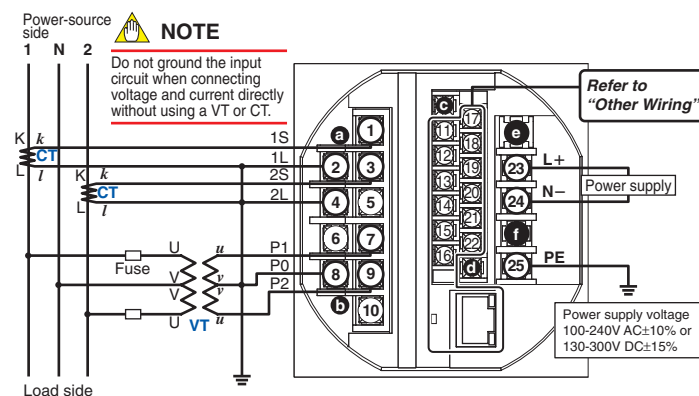

### 2.3 Three-phase three-wire system

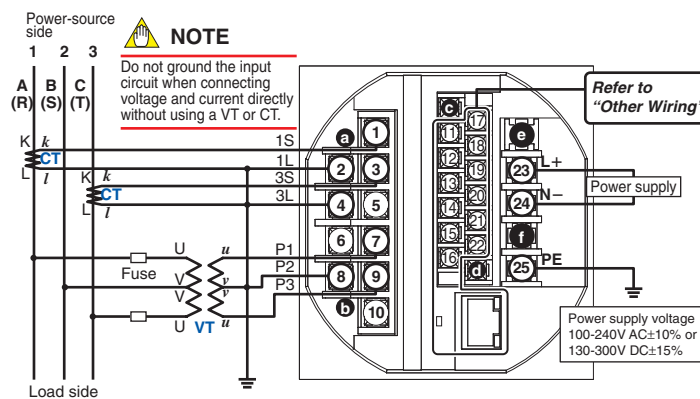

### 2.4 Three-phase four-wire system

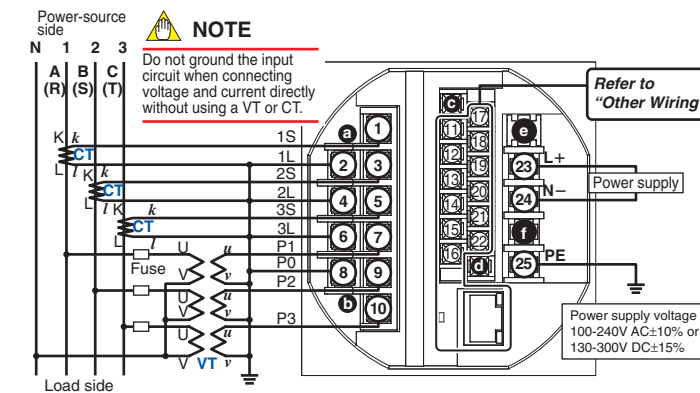

### 2.5 Three-phase four-wire system (2.5 element)

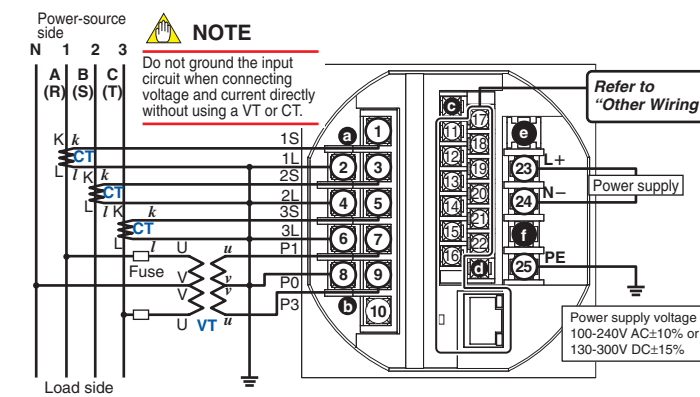

### 2.6 Other Wiring

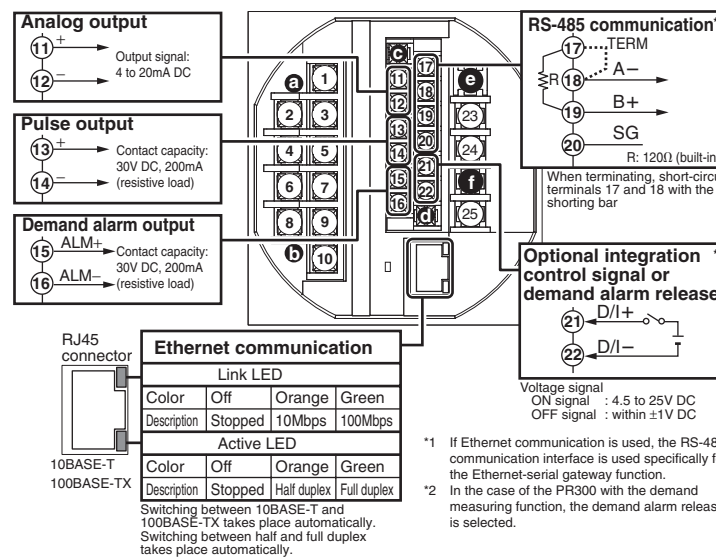

## 3. Attaching the Dust Cover and Terminal Cover



### CAUTION

As there is a danger of electric shock, do not attach the dust cover and terminal cover while the wires are live.

- Attach the dust cover before attaching the terminal cover.
- The recommended tightening torque for the screws for attaching the dust cover and terminal cover is 0.4 N·m.

### 3.1 Attaching the Dust Cover

- Insert the two protruding portions on the underside of the dust cover into the grooves on the upper side of the PR300 as shown in the diagram below.

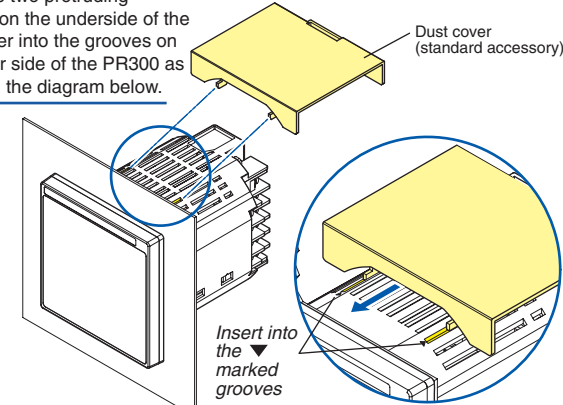

- Secure the dust cover with the screw provided as shown in the diagram below. (recommended tightening torque: 0.4 N·m)

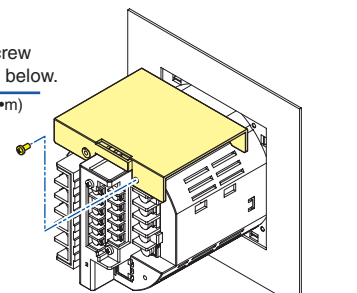

### 3.2 Attaching the Terminal Cover

- Complete the wiring to the terminals 2, 4, 6, 8, 23, 24, and 25, then secure the terminal cover in the open state shown in the diagram below with the two screws provided. (recommended tightening torque: 0.4 N·m)
- Complete the wiring to other terminals with the terminal cover open shown in the diagram below.

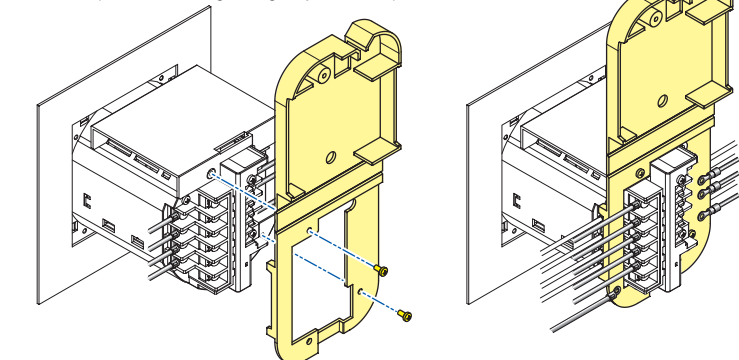

- Close the terminal cover and secure it with the screw provided as shown in the diagram below. (recommended tightening torque: 0.4 N·m)

