

Allied Vision Manta



Technical Manual

GigE Vision Cameras

V7.2.0

20 March 2015

Legal notice

For customers in the U.S.A.

This equipment has been tested and found to comply with the limits for a Class B digital device, pursuant to Part 15 of the FCC Rules. These limits are designed to provide reasonable protection against harmful interference when the equipment is operated in a residential environment. This equipment generates, uses, and can radiate radio frequency energy and, if not installed and used in accordance with the instruction manual, may cause harmful interference to radio communications. However there is no guarantee that interferences will not occur in a particular installation. If the equipment does cause harmful interference to radio or television reception, the user is encouraged to try to correct the interference by one or more of the following measures:

- Reorient or relocate the receiving antenna.
- Increase the distance between the equipment and the receiver.
- Use a different line outlet for the receiver.
- Consult a radio or TV technician for help.

You are cautioned that any changes or modifications not expressly approved in this manual could void your authority to operate this equipment. The shielded interface cable recommended in this manual must be used with this equipment in order to comply with the limits for a computing device pursuant to Subpart B of Part 15 of FCC Rules.

For customers in Canada

This apparatus complies with the Class B limits for radio noise emissions set out in the Radio Interference Regulations.

Pour utilisateurs au Canada

Cet appareil est conforme aux normes classe B pour bruits radioélectriques, spécifiées dans le Règlement sur le brouillage radioélectrique.

Life support applications

These products are not designed for use in life support appliances, devices, or systems where malfunction of these products can reasonably be expected to result in personal injury. Allied Vision Technologies customers using or selling these products for use in such applications do so at their own risk and agree to fully indemnify Allied for any damages resulting from such improper use or sale.

Trademarks

Unless stated otherwise, all trademarks appearing in this document of Allied Vision Technologies are brands protected by law.

Warranty

The information provided by Allied Vision Technologies is supplied without any guarantees or warranty whatsoever, be it specific or implicit. Also excluded are all implicit warranties concerning the negotiability, the suitability for specific applications or the non-breaking of laws and patents. Even if we assume that the information supplied to us is accurate, errors and inaccuracy may still occur.

Copyright

All texts, pictures and graphics are protected by copyright and other laws protecting intellectual property. It is not permitted to copy or modify them for trade use or transfer, nor may they be used on websites.

Allied Vision Technologies GmbH 03/2015

All rights reserved.

Managing Director: Mr. Frank Grube

Tax ID: DE 184383113

Headquarters:

Taschenweg 2a

D-07646 Stadtroda, Germany

Tel.: +49 (0)36428 6770

Fax: +49 (0)36428 677-28

e-mail: info@alliedvision.com

Contents

Contacting Allied Vision	7
Introduction	8
Document history	8
Manual conventions	17
Styles	17
Symbols	17
More information	18
Before operation	18
Camera cleaning	19
Warranty	19
Avoiding the necessity of camera cleaning	20
Identifying impurities	20
Locating impurities	21
Cleaning Instructions	21
Manta GigE cameras	24
Conformity	25
FCC – Class B Device	25
Specifications	26
Manta G-031B/C	26
Manta G-032B/C	29
Manta G-033B/C	31
Manta G-046B/C	33
Manta G-095B/C	35
Manta G-125B/C	37
Manta G-145B/C (-30fps)	39
Manta G-145B NIR	41
Manta G-146B/C	43
Manta G-201B/C (-30fps)	45
Manta G-223B/C (NIR)	47
Manta G-235B/C	49
Manta G-282B/C	51
Manta G-283B/C	53
Manta G-419B/C (NIR)	55
Manta G-504B/C	57
Manta G-505B/C	59

Manta G-609B/C	61
Manta G-917B/C	63
Camera smart features	65
Filter and lenses	66
IR cut filter: spectral transmission	66
Camera lenses	66
Camera dimensions (type A)	71
Tripod adapter	71
Manta standard housing (type A).....	72
Manta standard angled-head housings (type A).....	73
Manta W90	73
Manta W90 S90.....	74
Manta W270.....	75
Manta W270 S90	76
Manta standard board level variants (type A)	77
Manta type A board level (non-PoE): dimensions.....	77
Manta type A board level (PoE): dimensions	78
Manta type A board level (non-PoE): C-Mount.....	79
Manta type A board level (PoE): C-Mount	80
Manta type A board level (non-PoE): CS-Mount	81
Manta type A board level (PoE): CS-Mount	82
Manta type A board level (non-PoE): M12-Mount.....	83
Manta type A board level (PoE): M12-Mount	84
Cross section: C-Mount (type A)	85
Cross section: CS-Mount (type A).....	86
Camera dimensions (type B)	87
Tripod adapter	87
Manta standard housing (type B).....	88
Manta CMOS angled-head housings (type B)	89
Manta W90	89
Manta W90 S90.....	90
Manta W270.....	91
Manta W270 S90	92
Manta CMOS board level variants (type B)	93
Manta CMOS board level cameras: dimensions.....	93
Manta CMOS (type B) board level cameras: C-Mount.....	94
Manta CMOS (type B) board level cameras: CS-Mount	95
Manta CMOS (type B) board level cameras: M12-Mount.....	96
Cross section: C-Mount (type B)	97
Cross section: CS-Mount (type B).....	98

Camera interfaces	99
Gigabit Ethernet port	99
Camera I/O connector pin assignment (incl. PoE)	100
Manta input block diagram	101
Manta output block diagram	102
Status LEDs	104
Status LEDs Manta type A.....	104
Status LEDs Manta type B.....	105
Video iris output description.....	106
Control signals	107
Inputs	107
Input/output pin control.....	107
Outputs	107
Trigger timing diagram	109
Notes on triggering	109
Camera data path	112
Camera block diagrams.....	112
Manta type A: monochrome cameras.....	112
Manta type A: color cameras.....	112
Manta type B: monochrome CCD cameras	113
Manta type B: color CCD cameras.....	113
Manta type B: monochrome CMOS cameras.....	114
Manta type B: color CMOS cameras	115
Camera features	116
Frame memory.....	126
Color interpolation (Bayer demosaicing).....	127
Resolution and ROI frame rates	129
Manta G-031B/C: ROI frame rates	130
Manta G-032B/C: ROI frame rates	131
Manta G-033B/C: ROI frame rates	132
Manta G-046B/C: ROI frame rates	133
Manta G-095B/C: ROI frame rates	134
Manta G-125B/C: ROI frame rates	135
Manta G-145B/C: ROI frame rates	136
Manta G-145B/C-30fps: ROI frame rates.....	137
Manta G-145B NIR: ROI frame rates.....	138
Manta G-146B/C: ROI frame rates	140
Manta G-201B/C: ROI frame rates	141
Manta G-201B/C-30fps: ROI frame rates.....	142
Manta G-223B/C (NIR): ROI frame rates	143

Manta G-235B/C: ROI frame rates	144
Manta G-282B/C: ROI frame rates	145
Manta G-283B/C: ROI frame rates	146
Manta G-419B/C (NIR): ROI frame rates	147
Manta G-504B/C: ROI frame rates	148
Manta G-505B/C: ROI frame rates	149
Manta G-609B/C: ROI frame rates	150
Manta G-917B/C: ROI frame rates	151
Appendix	152
Sensor position accuracy of Manta cameras	152
Exceptions for non-PoE Manta cameras up to serial number 503323258	153
Manta standard housing	153
Manta W90 housing	154
Manta W90 S90 housing	155
Manta W270 housing	156
Manta W270 S90 housing	157
Manta board level (non-POE)	158
Camera I/O connector pin assignment.....	159
Status LEDs.....	160
Index	161

Contacting Allied Vision

Info



- **Technical information:**
<http://www.alliedvision.com>
- **Support:**
support@alliedvision.com

Allied Vision Technologies GmbH (Headquarters)

Taschenweg 2a
07646 Stadtroda, Germany
Tel.: +49 36428-677-0
Fax: +49 36428-677-28
e-mail: info@alliedvision.com

Allied Vision Technologies Canada Inc.

101-3750 North Fraser Way
Burnaby, BC, V5J 5E9, Canada
Tel.: +1 604-875-8855
Fax: +1 604-875-8856
e-mail: info@alliedvision.com

Allied Vision Technologies Inc.

38 Washington Street
Newburyport, MA 01950, USA
Toll Free number +1 877-USA-1394
Tel.: +1 978-225-2030
Fax: +1 978-225-2029
e-mail: info@alliedvision.com

Allied Vision Technologies Asia Pte. Ltd.

82 Playfair Road
#07-02 D'Lithium
Singapore 368001
Tel.: +65 6634-9027
Fax: +65 6634-9029
e-mail: info@alliedvision.com

Allied Vision Technologies (Shanghai) Co., Ltd.

2-2109 Hongwell International Plaza
1602# ZhongShanXi Road
Shanghai 200235, China
Tel.: +86 (21) 64861133
Fax: +86 (21) 54233670
e-mail: info@alliedvision.com

Introduction

Manta Technical Manual describes in depth the technical specifications, dimensions, all pixel formats, bandwidth and frame rate related subjects.

For information on hardware installation, safety warnings, pin assignments on I/O connectors and GigE port connectors, read the **GigE Installation Manual**.

For information on camera features, read the **GigE Features Reference** document.

Note

Please read through this manual carefully.



We assume that you have read already the **GigE Installation Manual** and that you have installed the hardware and software on your PC or laptop (Gigabit Ethernet network card, cables).

<http://www.alliedvision.com/en/support/technical-documentation/manta-documentation>

Document history

Version	Date	Remarks
V2.0.3	15.04.10	New Manual - RELEASE status
V3.0.0	09.06.10	Added Manta G-046, G-145, G-201, G-146: <ul style="list-style-type: none"> • chapter Manta G-046B/C on page 33 • chapter Manta G-145B/C (-30fps) on page 39 • chapter Manta G-146B/C on page 43 • chapter Manta G-201B/C (-30fps) on page 45 • chapter Spectral sensitivity on page 57 • Table 48 : Image memory size (typical; see note above) on page 126 • chapter Manta G-046B/C: ROI frame rates on page 133 • chapter Manta G-145B/C: ROI frame rates on page 136 • chapter Manta G-146B/C: ROI frame rates on page 140 • chapter Manta G-201B/C: ROI frame rates on page 141
to be continued on next page		

Table 1: Document history

Version	Date	Remarks
continued from last page		
V3.0.0 [continued]	09.06.10 [continued]	<p>[continued]</p> <ul style="list-style-type: none"> • With the new firmware 1.40 due to a bug all Manta models have only 12 bit in the data path (even if the ADC delivers 14 bit): See figure 85 and figure 86. • Due to a repaired bug in FPGA and microcontroller, the StreamHoldCapacity changed: Manta G-032 from 49 frames to 99 frames, Manta G-125 from 12 frames to 25 frames: see chapter Manta G-032B/C on page 29 and chapter Manta G-125B/C on page 37 • RGBA24 and BGRA24 are not supported, see chapter Specifications on page 26. • Manta board level cameras have now a cooling plate: see <ul style="list-style-type: none"> – chapter Manta type A board level (PoE): dimensions on page 78 – chapter Manta type A board level (PoE): C-Mount on page 80 – chapter Manta type A board level (PoE): CS-Mount on page 82 – chapter Manta type A board level (PoE): M12-Mount on page 84 • Added chapter Firmware update on page 87
V4.0.0	25.10.10	<ul style="list-style-type: none"> • Added the information, that description of status LEDs can be found in Manta Hardware Installation Guide, see Note on page 109 • Changed file format from FM7 to FM9 <p>Added Manta G-033B/C (sensor: Sony ICX 414) and Manta G-504B/C (sensor: Sony ICX 655):</p> <ul style="list-style-type: none"> • Manta G-033B/C on page 31 • Manta G-504B/C on page 57 • Spectral sensitivity on page 57. • Camera lenses on page 66 • Table 48 : Image memory size (typical; see note above) on page 126 • chapter Resolution and ROI frame rates on page 129 • Manta angled head models: chapter Manta W90 on page 73
V4.0.1	05.01.11	<ul style="list-style-type: none"> • Changed tripod drawing: added dimensions of three big holes (M6 and UNC 1/4-20) in Figure 46: Tripod dimensions on page 71. • In specifications tables color pixel formats: inserted Mono8. Added Note, that Raw8, Raw16 displayed in some viewers means the same as Bayer8, Bayer16: see chapter Specifications on page 26. • Changed GigE Vision V1.0 to V1.2 in all specification tables in chapter Specifications on page 26.
to be continued on next page		

Table 1: Document history

Version	Date	Remarks
continued from last page		
V4.1.0	24.06.11	<p>Added PoE:</p> <ul style="list-style-type: none"> • Added power requirements, power consumption and regulations for Manta PoE models: see chapter Specifications on page 26. • Added note about PoE capable cameras in chapter Specifications on page 26 and chapter Gigabit Ethernet port on page 99 • PoE cameras < 220 g (without lens): see chapter Specifications on page 26. <p>Corrected frame rate formulas for Manta G-033/G504:</p> <ul style="list-style-type: none"> • See chapter Manta G-033B/C: ROI frame rates on page 132 and chapter Manta G-504B/C: ROI frame rates on page 148 <p>C-/CS-Mount no more adjustable, for modifications contact Customer Care and send camera to AVT:</p> <ul style="list-style-type: none"> • See C/CS-Mount descriptions in specification tables in chapter Specifications on page 26. • See chapter Adjusting C-Mount on page 97 • See chapter Adjusting CS-Mount on page 86 <p>Manta board level:</p> <ul style="list-style-type: none"> • Manta board level: deleted (PWR output on demand) at Pin2: in Figure 53: Dimensions for Manta type A board level (PoE): Manta G-031 / 032 / 033 / 046 / 095 / 125 / 145 / 146 / 201 / 504 on page 78 <p>Added new address:</p> <ul style="list-style-type: none"> • Added Singapore address in chapter Contacting Allied Vision on page 7 <p>Removed Chapter Firmware update (see Knowledge Base at AVT Website: search for Application Note GigE Firmware Update)</p> <p>Manta firmware upgrade:</p> <ul style="list-style-type: none"> • Revised data path block diagram in chapter Camera block diagrams on page 112 • Added 30fps variant for Manta G-145-30fps and Manta G-201-30fps: <ul style="list-style-type: none"> – see chapter Manta G-145B/C (-30fps) on page 39 and Formula 9: Manta G-145-30fps: theoretical maximum frame rate of CCD on page 137 and chapter Frame memory on page 126 – chapter Manta G-201B/C (-30fps) on page 45 and chapter Frame memory on page 126 • Added Mono12Packed for monochrome cameras and Bayer12Packed for color cameras: see chapter Specifications on page 26.
to be continued on next page		

Table 1: Document history

Version	Date	Remarks
continued from last page		
[continued] V4.1.0	[continued] 24.06.11	<p>[continued]</p> <ul style="list-style-type: none"> Added the following camera controls in chapter Camera features on page 116.: <ul style="list-style-type: none"> – Chunk Data – EventControls – StreamFramerateConstrain – FrameStartTriggerOverlap – PayloadSize – NonImagePayloadSize – SyncInGlitchFilter – AutoIris – Gamma – LUT <p>Manta G-145-30fps and Manta G-201-30fps (non PoE)</p> <ul style="list-style-type: none"> ... have same I/O pin assignment (input circuits and voltage range), power LED and upside down PoE plug as PoE models: see exception on page 100 Manta G-145-30fps / 201-30fps non-PoE behave like PoE cameras. on page 100
V5.0.0	15.05.12	<p>Error found in Document history V3.0.0 by Validation Team:</p> <ul style="list-style-type: none"> RGBA24 and BGRA24 should be named RGBA32 and BGRA32 on page 9 Added RGBA32 and BGRA32 color formats (except Manta G-201-30fps) in chapter Specifications on page 26. Added frame rate diagrams in chapter Resolution and ROI frame rates on page 129. <p>New: Manta G-145 NIR:</p> <ul style="list-style-type: none"> NirMode in chapter Camera features on page 116 New: For the three NirModes: chapter Manta G-145B NIR: ROI frame rates on page 138 <ul style="list-style-type: none"> – chapter Manta G-145B NIR on page 41 – Figure 21 : Spectral sensitivity of Manta G-145B NIR (Nir-Mode=On_Fast or On_HighQuality) compared to Manta G-145B on page 42 – Figure 22 : Increase of relative response for Manta G-145B NIR with NIR mode set to On_HighQuality on page 42 – chapter : Image memory size (typical; see note above) on page 126 – chapter Manta G-145B NIR: ROI frame rates on page 138 – Chapter Manta cameras: frame rate comparison on page 129
to be continued on next page		

Table 1: Document history

Version	Date	Remarks
continued from last page		
V5.0.0 [continued]	15.05.12 [continued]	<p>New sensors ICX618 and ICX692:</p> <ul style="list-style-type: none"> • Manta G-031 (ICX618): <ul style="list-style-type: none"> – chapter Manta G-031B/C on page 26 – Figure 7: Spectral sensitivity of Manta G-031B (without protection/cover glass) on page 28 – Figure 8: Spectral sensitivity of Manta G-031C (without IR cut filter) on page 28 – New: Table 23: Focal length vs. field of view (Manta G-031) on page 67 – chapter : Image memory size (typical; see note above) on page 126 – chapter Manta G-031B/C: ROI frame rates on page 130 – Chapter Manta cameras: frame rate comparison on page 129 • Manta G-095C (ICX692): <ul style="list-style-type: none"> – chapter Manta G-095B/C on page 35 – Added focal length 4.0 mm in Table 25: Focal length vs. field of view (Manta G-095/125) on page 67 – Figure 16: Spectral sensitivity of Manta G-095C (without IR cut filter) on page 36 – chapter : Image memory size (typical; see note above) on page 126 – chapter Manta G-095B/C: ROI frame rates on page 134 – Chapter Manta cameras: frame rate comparison on page 129 • Added Manta G-031 and Manta G-095 in Chapter Manta cameras: frame rate comparison on page 129 <p>Same main board for all Manta models: From serial number 503323258 on all Manta models incl. PoE and board level versions contain the same main board.</p> <ul style="list-style-type: none"> • chapter Gigabit Ethernet port on page 99 • chapter Camera I/O connector pin assignment (incl. PoE) on page 100 <p>Revised non-PoE drawings and new board level PoE drawings:</p> <ul style="list-style-type: none"> • chapter Manta type A board level (non-PoE): dimensions on page 77 • chapter Manta type A board level (PoE): dimensions on page 78 • chapter Manta type A board level (non-PoE): C-Mount on page 79 • chapter Manta type A board level (PoE): C-Mount on page 80 • chapter Manta type A board level (non-PoE): CS-Mount on page 81 • chapter Manta type A board level (PoE): CS-Mount on page 82 • chapter Manta type A board level (non-PoE): M12-Mount on page 83 chapter Manta type A board level (PoE): M12-Mount on page 84
to be continued on next page		

Table 1: Document history

Version	Date	Remarks
continued from last page		
V5.0.0 [continued]	15.05.12 [continued]	<p>Revised PoE descriptions regarding 802.3af and 802.3at:</p> <ul style="list-style-type: none"> See note in Gigabit Ethernet port on page 99 (Manta PoE models can source power from 802.3af (100 MBit/s and 1000 MBit/s) and from 802.3at compliant PSE devices (Power Sourcing Equipment): such as switches injectors or NICs.) <p>New CAD drawings with Pin3 = Video Type Auto Iris Out</p> <ul style="list-style-type: none"> chapter Manta type A board level (non-PoE): dimensions on page 77 chapter Manta type A board level (PoE): dimensions on page 78 <p>Frame memory</p> <ul style="list-style-type: none"> Manta G-032B/C: changed from 49 to 99 frames. Manta G-033B/C: changed from 88 to 99 frames. Manta G-046B/C: changed from 35 to 70 frames. Manta G-125B/C: changed from 12 to 25 frames. Manta G-145B/C: changed from 10 to 22 frames. Manta G-145B/C-30fps: changed from 10 to 22 frames. Manta G-146B/C: changed from 10 to 22 frames. Manta G-201B/C: changed from 8 to 16 frames. Manta G-201B/C-30fps: changed from 8 to 16 frames. <p>Added frame rates for ROI height = 720</p> <ul style="list-style-type: none"> chapter Manta G-095B/C: ROI frame rates on page 134 chapter Manta G-125B/C: ROI frame rates on page 135 <p>IR cut filter:</p> <p>Changed IR cut filter to (<i>type Jenofilt 217</i>): see Figure 45: Approximate spectral transmission of IR cut filter (may vary slightly by filter lot) (type Hoya C5000) on page 66</p>
V5.0.1	23.05.12	<p>For Manta G-095C: Corrected frame rate value (at ROI height 720): 40.77 fps, see chapter Manta G-095B/C: ROI frame rates on page 134.</p>
V6.0.1	2013-Mar-20	<p>Major changes: Added new Manta models: Manta G-223 / 282 / 283 / 609 / 917. These models are called Manta type B, since there are some differences to the other models that are called Manta type A (specifications, housing, data path, features).</p> <p>New tripod adapter, new CAD drawings with LEDs on top of the connector, see Camera dimensions (type A) on page 71 and Camera dimensions (type B) on page 87.</p>
to be continued on next page		

Table 1: Document history

Version	Date	Remarks
continued from last page		
V6.0.1 [continued]	2013-Mar-20 [continued]	<p>In chapter Specifications on page 26, the pixel formats are listed both for PvAPI and VIMBA (GenICam V1.0).</p> <p>Added chapter Video iris output description on page 106.</p> <p>I/O pin assignment: 10 mA on outputs 1 and 2 (not 20 mA), see Camera I/O connector pin assignment (incl. PoE) on page 100</p> <p>Minor changes: Manta G-031: External trigger delay, see chapter Manta G-031B/C on page 26.</p> <p>Corrected the mass (200 g) of Manta type A cameras (G-031 / 032 / 033 / 046 / 095 / 125 / 145 / 146 / 201 / 504).</p> <p>PoE models: compliant with Power over Ethernet IEEE 802.3at/af</p> <p>Deleted the Chapter <i>Manual Overview</i> Deleted <i>Frame Rate Comparison of all Manta cameras</i></p> <p>New date format: year-month-day</p>
V7.0.0	2013-Aug-30	<p>Added new Manta models: Manta G- 095B, G-419B/C</p> <p>As of this version, the document refers to AVT's VIMBA SDK (not PvAPI)</p> <p>Changed cable recommendation to Category 6 or higher, see chapter Gigabit Ethernet port on page 99</p> <p>Manta G-145B/C-30 fps: changed framerate</p> <p>Chapter chapter Camera interfaces on page 99: added input/output block diagrams and the status LED description</p> <p>Changed minimum exposure times of Manta G-223 /G-419, see Manta G-223B/C (NIR) and Manta G-419B/C (NIR)</p> <p>Changed ROI frame rates of Manta G-145 (-30 fps), see chapter Frame rates Manta G-145 as function of ROI height[width=1388] on page 136 and following</p>
to be continued on next page		

Table 1: Document history

Version	Date	Remarks
continued from last page		
V7.0.1	2013-Sep-30	<p>Added Camera cleaning on page 19</p> <p>Changed maximum frame rates and gain range, added burst mode for Manta G-223, G-419, see Manta G-223B/C (NIR) on page 47, Manta G-419B/C (NIR) on page 55 and chapter Resolution and ROI frame rates on page 129</p> <p>Added a feature of Manta type B cameras (G-223 / 235 / 282 / 283 / 419 / 505 / 609 / 917): temperature monitoring, see chapter Specifications on page 26</p> <p>Added ReverseX feature in chapter Camera features on page 116</p> <p>Added Manta angled-head housings (type B) on page 100</p> <p>Updated maximum gain values for Manta G-283B/C and Manta G-917B/C</p> <p>Updated minimum exposure time for Manta G-145B/C (-30fps)</p> <p>Updated the frame rate vs. height graphs in chapter Resolution and ROI frame rates on page 129</p> <p>Updated links to the AVT GigE installation manual through out the manual</p>
V7.0.2	2014-May-08	<ul style="list-style-type: none"> • Updated chapter Camera block diagrams on page 112 • Updated drawings for Manta type A board level (non-PoE): dimensions and Manta type A board level (PoE): dimensions • Updated spectral sensitivity plots in Specifications on page 26 • Updated the note on StreamHoldCapacity in Specifications and Frame memory sections • Added section Exceptions for non-PoE Manta cameras up to serial number 503323258 on page 153 • Updated available color pixel formats for Manta G-223B/C (NIR) and Manta G-419B/C (NIR) • Updated optional accessories in the Specifications chapter • Added section Manta standard board level variants (type B) • Added Hirose cable information on page 100 • Updated exposure time values for Manta G-145B NIR, Manta G-145B/C (-30fps), Manta G-223B/C (NIR), Manta G-282B/C, and Manta G-283B/C • Corrected frame rate formula for Manta G-145B NIR on page 138
V7.0.3	2014-Jun-09	<ul style="list-style-type: none"> • Added trigger latency and jitter values in the Specifications chapter • Updated and rearranged Specifications chapter • Added Camera smart features section on page 65 • Preliminary Manta type B angled-head and boardlevel variant information removed from the document until samples are available
to be continued on next page		

Table 1: Document history

Version	Date	Remarks
continued from last page		
V7.1.0	2014-Oct-07	<ul style="list-style-type: none"> • Updated the following in the Specifications chapter <ul style="list-style-type: none"> – Trigger latency and jitter values – Decimation control descriptions changed to GenICam factor style • Added <i>BufferHandlingControl</i> and <i>StreamInformation</i> in Camera features section, applicable for Vimba v1.3 or higher • Updated Camera features section • Updated datapath diagrams for color cameras in Camera data path section • Added new camera model Manta G-505B/C <ul style="list-style-type: none"> – Manta G-505B/C specifications – Camera lens information in table 33 – Description of data path – Manta G-505B/C: ROI frame rates information • Added new camera model Manta G-235B/C <ul style="list-style-type: none"> – Manta G-235B/C specifications – Camera lens information in table 29 – Description of data path for Manta G-235B and Manta G-235C – Manta G-235B/C: ROI frame rates information • Added the following sections: <ul style="list-style-type: none"> – Manta CMOS angled-head housings (type B) – Manta CMOS board level variants (type B) – Cross section: CS-Mount (type B)
V7.2.0	2015-Mar-20	<ul style="list-style-type: none"> • Updated Allied Vision logo • Replaced references of AVT and Allied Vision Technologies to Allied Vision • Updated links to new Allied Vision website • Renamed Description of data path chapter to Camera data path

Table 1: Document history

Manual conventions

To give this manual an easily understood layout and to emphasize important information, the following typographical styles and symbols are used:

Styles

Style	Function	Example
Bold	Programs, inputs or highlighting important things	bold
Courier	Code listings etc.	Input
Upper case	Register	REGISTER
Italics	Modes, fields	<i>Mode</i>
Parentheses and/or blue	Links	(Link)

Table 2: Styles

Symbols

Note This symbol highlights important information.



Caution This symbol highlights important instructions. You have to follow these instructions to avoid malfunctions.



www This symbol highlights URLs for further information. The URL itself is shown in blue.



Example:

<http://www.alliedvision.com>

More information

For more information on hardware and software read the following:

- **GigE Installation Manual** describes the hardware installation procedures for Allied Vision GigE cameras. Additionally, it includes safety instructions and information about camera interfaces (GigE port, PoE, I/O connectors, input and output).
- **GigE Features Reference** describes the camera features of the Allied Vision GigE SDK (Vimba) and feature related items.

www



For downloading **GigE Installation Manual** and **GigE Features Reference** go to:

<http://www.alliedvision.com/en/support/technical-documentation/manta-documentation>

www



All **software packages** (including **documentation** and **release notes**) provided by Allied Vision can be downloaded from:

<http://www.alliedvision.com/en/support/software-downloads>

Before operation

Target group This **Technical Manual** is the guide to detailed technical information of the camera and **is written for experts**.

Getting started For a quick guide how to get started read the **GigE Installation Manual** first.

Note



Please read through this manual carefully before operating the camera.

Caution



Before operating any Allied Vision camera, read the **safety instructions** and **ESD warnings** in the **GigE Installation Manual**.

Camera cleaning

This chapter describes safety instructions/cautions valid for **Manta** cameras in case of cleaning lenses, optical filters/protection glass or sensors.

Note



- Please read these instructions before you contact your Allied Vision camera dealer for assistance.
- Ask your Allied Vision camera dealer if you are not familiar with the procedures described below.

Warranty

www

For details about camera warranty duration and sensor warranty terms, visit:



<http://www.alliedvision.com/en/support/warranty>

Caution



Warranty precautions

- To ensure your warranty remains in effect:
 - Do not open the camera housing.
 - Follow instructions described below.
 - Use only optical quality tissue/cloth if you must clean a lens or filter.
 - Use only optics cleaner (60% ethyl alcohol, 40% ether). Never use aggressive cleaners like benzine or spirit. Such cleaners may destroy the surface.
 - **Do not use compressed air which can push dust into camera and lens.**
- Allied Vision does not warranty against any physical damage to the sensor/filter/protection glass or lenses. **Use utmost care when cleaning optical components.**

Avoiding the necessity of camera cleaning

When screwing/unscrewing the camera lens or dust cap, hold the camera with the C-Mount / CS-Mount opening towards the floor as shown in figure 1. This minimizes the possibility of any contaminants falling on the glass surface. Always store cameras and lenses with dust-caps installed.



Figure 1: Illustration of camera orientation when removing lens or dust cap

Identifying impurities

If you observe any image artefacts in your video preview of your Manta camera you may have impurities either on the lens, filter/protection glass, or on the sensor protection glass. Every Manta camera is cleaned prior to sealing and shipment; however, impurities may develop due to handling or unclean environments.

As shown in figure 2, impurities (dust, particles or fluids) on the sensor or optical components appear as a dark area, patch or spot on the image and remain fixed in the preview window while you rotate the camera over the target.

Do not confuse this with a pixel defect which appears as a distinct point. Particles can either rest loosely or can be more or less stuck to the optical surface.

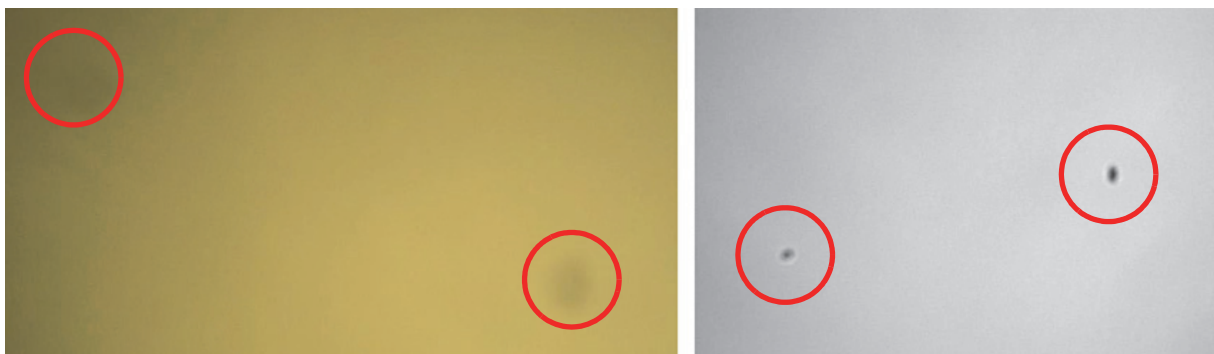

Figure 2: Image with tiny dust on the filter (left) and dust on the sensor (right)

Locating impurities

Before you dismount the lens you should find out if the impurity is on the filter, lens, or sensor. Therefore, you should capture a uniform image (e.g. a white sheet of paper) with the camera. The affected optical surface is identified when a suspected optical component is moved and the dirt follows this movement.

1. If you move only the lens (not the camera) and the impurity moves as well, the impurity is on the lens.
2. If you move the IR cut filter/protection glass window and the impurity moves as well:

Please carefully remove the filter/protection glass and clean it on both sides using the techniques explained below.

Note



- Taking out the filter requires special care.
- Ask your dealer to help you if you are not confident with the procedure.



Figure 3: Removing IR cut filter/protection glass using special tool (E9020001)

3. If the impurity is neither on the lens nor the IR cut filter/protection glass, it is probably on the sensor.

Cleaning Instructions

Perform all cleaning operations (lenses, filter/protection glass, and sensor) in a **dust-free clean-room**. The optical components are very fragile so it is important to avoid touching them with your fingers or any hard material.

1. Unplug the camera from any power supply before cleaning.
2. Apply a small amount of optics cleaner (60% ethyl alcohol, 40% ether) to a clean, new lens cleaning tissue.

Acceptable material includes medical-grade sterile optical cotton, or lens tissue that is chemically pure and free from silicones and other additives.

- **Do not** use cosmetic cotton.
- **Do not** use consumer eyeglass cleaning cloths pre-treated with silicon.

The cotton or lens tissue should be moist, but not dripping. Please hold the camera away from your body to avoid falling particles like flakes from skin on the sensor. Hold the camera sensor diagonally upwards.



Figure 4: Medical-grade sterile optical cotton

3. Wipe the glass surface with a spiral motion from the center to the rim. Normally, several spiral wipes are recommended. Wipe only on glass avoiding contact to metal surfaces because microscopic dirt could be released and could cause scratches on the glass.
4. When you've finished cleaning, examine the surface in a strong light. Take an out-of-focus picture of a flat, illuminated surface to see if any dirt or dust remains.
5. If dust spots remain, repeat this procedure using a new clean lens tissue (as described above).

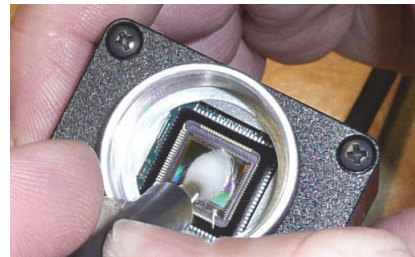

Figure 5: Sensor cleaning

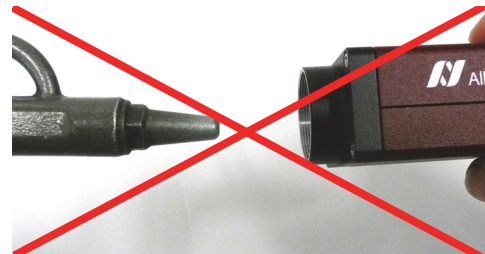

Figure 6: Do not use compressed air

Caution



- Never wipe lenses with dry swabs or tissue—this causes scratches.
- Do not use any disposable cotton cosmetic swabs; they may contain contaminants.

6. If you want to clean your camera with compressed air despite of all the warnings:

Caution

- Use an air blower/compressed air only if you are familiar with cleaning a camera with this instrument.
 - **Compressed air may push dust into cameras and lenses.** Therefore, keep the pressure at a moderate strength only:
 - The pressure at the tube should be less than 1 bar (15 psi)
 - Operating distance: 5–30 cm
7. Gently blow the impurities off with dust-filtered, oil-free air (< 1 bar). Using ionized air helps to remove any dirt stuck to the optical component because of static electricity.

Note

If dust spots remain after cleaning twice, please contact your Allied Vision dealer.

Manta GigE cameras

Manta Manta cameras have a **Gigabit Ethernet interface**.

GigE GigE is the abbreviation for **Gigabit Ethernet**.

All Manta cameras are GigE Vision V1.2 compliant cameras with Gigabit Ethernet interface. Manta cameras work with Gigabit Ethernet hardware and cable lengths up to 100 m.

GigE Vision The GigE Vision standard is an interface standard for digital machine vision cameras widely supported in the industrial imaging industry. In contrast, GigE (Gigabit Ethernet) is the network GigE Vision is built upon.

GenICam GenICam is the command structure for the GigE Vision camera controls. GenICam is administered by the European Machine Vision Association (EMVA). GenICam establishes a common camera control interface allowing third-party software to communicate with cameras from various manufacturers without customization. Allied Vision GigE cameras are GenICam V1.0 compliant.

www



For further information on the highlights of Manta cameras and the whole range of **Allied Vision GigE cameras**, read the data sheets and brochures on Allied Vision website:

<http://www.alliedvision.com/en/products/cameras>

Conformity

Allied Vision Technologies declares under its sole responsibility that all standard cameras of the **Allied Vision Manta** family to which this declaration relates are in conformity with the following standard(s) or other normative document(s):

- CE, following the provisions of 2004/108/EG directive (**Manta** board level cameras do not have CE)
- FCC Part 15 Class B (**Manta** board level cameras: prepared for FCC Class B)
- RoHS (2011/65/EU)
- WEEE 

We declare, under our sole responsibility, that the previously described **Allied Vision Manta** cameras conform to the directives of the CE.

FCC – Class B Device

Note: This equipment has been tested and found to comply with the limits for a Class B digital device, pursuant to part 15 of the FCC Rules. These limits are designed to provide reasonable protection against harmful interference in a residential environment. This device complies with part 15 of the FCC Rules. Operation is subject to the following two conditions: (1) This device may not cause harmful interference, and (2) this device must accept any interference received, including interference that may cause undesired operation. This equipment generates, uses, and can radiate radio frequency energy and, if not installed and used in accordance with the instructions, may cause harmful interference to radio communications. Operation of this equipment in a residential area is likely to cause harmful interference in which case the user will be required to correct the interference at his own expense. You are cautioned that any changes or modifications not expressly approved in this manual could void your authority to operate this equipment.

Specifications

Caution



Before operating any Allied Vision camera, read the **safety instructions** and **ESD warnings** in the **GigE Installation Manual**.

http://www.alliedvision.com/fileadmin/content/documents/products/cameras/various/installation-manual/GigE_Installation_Manual.pdf

Note



PoE capable cameras

How can I distinguish between PoE capable cameras and cameras that are not PoE capable?

PoE capable cameras have the letters **PoE** written on the camera's label on the bottom side of the camera.

Note



All measurements were done without protection glass / IR cut filter. With glass or filters, quantum efficiency decreases by approximately 10%.

The uncertainty in measurement of the QE values is $\pm 10\%$.

This is due to:

- Manufacturing tolerance of the sensor
- Uncertainties in the measuring apparatus itself (Ulbricht sphere, optometer, etc.)

The measurements for Manta G-145B NIR in figure 21 and figure 22 were done with a different method to illustrate the effect of the NIR mode.

Manta G-031B/C

Feature	Specification
Resolution	656 x 492
Sensor	SONY IT CCD ICX618AL/AQ with EXview HAD CCD II microlens
Type	CCD Progressive
Sensor size	Type 1/4
Cell size	5.6 μm
Lens mount	C / CS-Mount
Max frame rate at full resolution	125 fps

Table 3: Manta G-031B/C camera specifications

Feature	Specification
Max image bit depth	12 bit
On-board FIFO	32 MByte, up to 99 frames at full resolution, Mono8/Bayer8, and a <i>GevSCPSPacketSize</i> = 8192 bytes per packet
Mono formats	Mono8, Mono12Packed, Mono12
Color formats	BayerRG8, BayerRG12Packed, BayerGR12, Mono8, RGB8Packed, YUV411Packed, YUV422Packed, YUV444Packed, BGR8Packed, RGBA8Packed, BGRA8Packed
Exposure control	58 μ s to 60 s; 1 μ s increments
Gain control	0–32 dB
Binning	Horizontal: 1 to 8 columns; Vertical: 1 to 14 rows
Decimation	Horizontal and Vertical: 1, 2, 4, 8 factor
Opto-coupled I/Os	2 input, 2 outputs
RS-232	1 TxD, 1 RxD
Voltage requirements	8–30 VDC, or PoE
Power consumption	3.7 W @ 12 VDC, 4.3 W PoE
Trigger latency*	Idle state: 9.9 μ s Frame valid state: 16.5 μ s
Trigger jitter*	Idle state: 5.3 μ s Frame valid state: 11.9 μ s
Operating temperature	+5 °C to +45 °C ambient temperature (without condensation)
Storage temperature	-10 °C to +70 °C ambient temperature (without condensation)
Body dimensions (L x W x H)	86.4 mm x 44 mm x 29 mm including connectors, w/o tripod and lens
Mass	200 g (without lens)
Hardware interface standard	PoE, IEEE 802.3af 1000BASE-T, 100BASE-TX
Software interface standard	GigE Vision Standard 1.2
Camera control interface	GenICam V1.0 compliant
Regulatory	CE, FCC Class B, RoHS (2011/65/EU)
<p>*It is possible to start the exposure of the next frame while the previous frame is read out:</p> <ul style="list-style-type: none"> – Idle state: sensor is ready and camera is idle, waiting for the next trigger – Frame valid state: sensor is reading out and camera is busy. If the next frame is requested by an external trigger in this state, higher latency may occur as compared to the Idle state 	

Table 3: Manta G-031B/C camera specifications

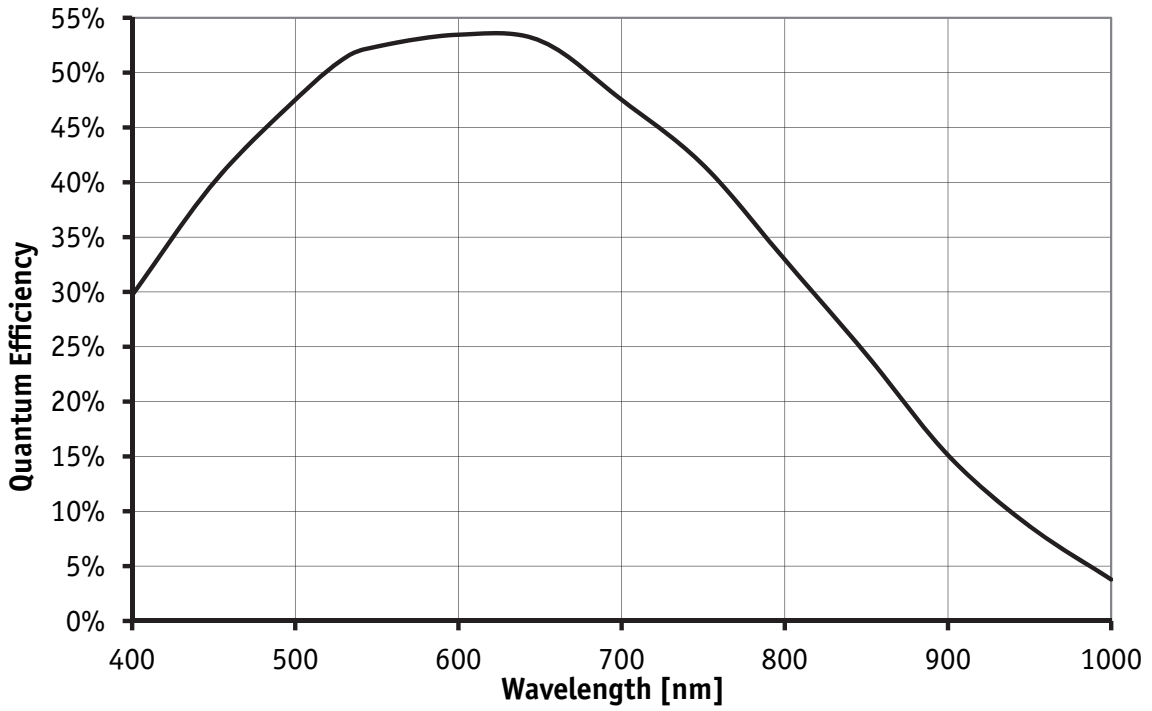

Figure 7: Spectral sensitivity of Manta G-031B (without protection/cover glass)

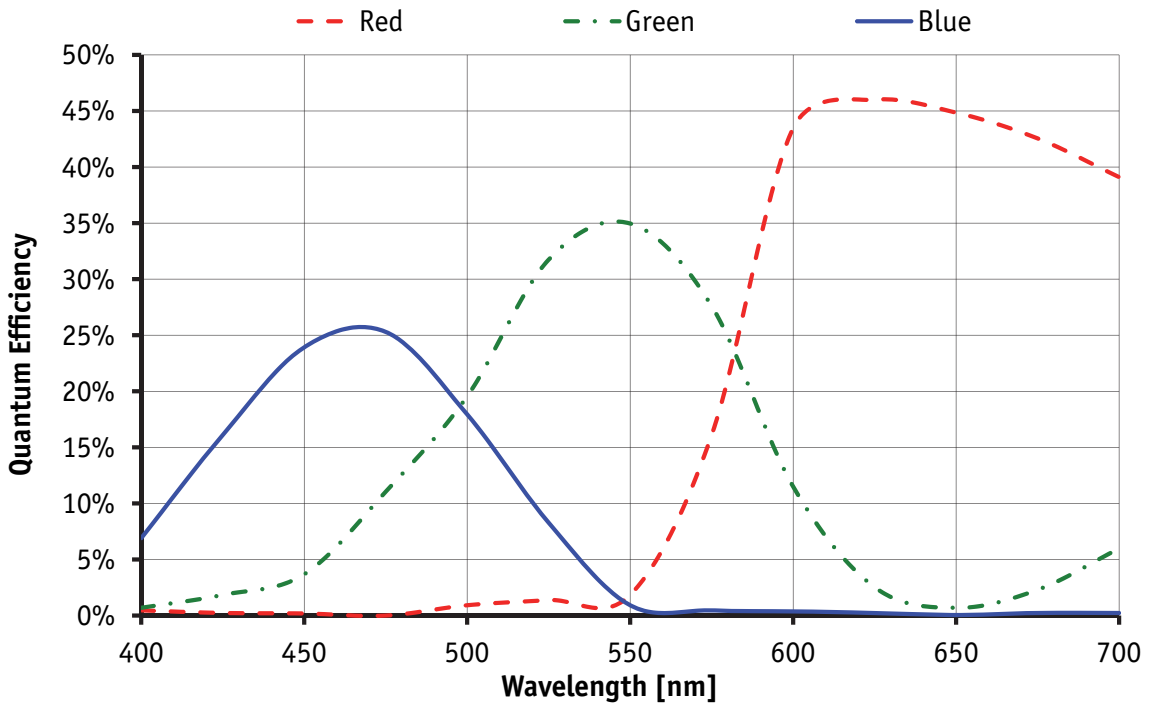

Figure 8: Spectral sensitivity of Manta G-031C (without IR cut filter)

Manta G-032B/C

Feature	Specification
Resolution	656 x 492
Sensor	SONY IT CCD ICX424AL/AQ with HAD microlens
Type	CCD Progressive
Sensor size	Type 1/3
Cell size	7.4 μm
Lens mount	C / CS-Mount
Max frame rate at full resolution	80 fps
Max image bit depth	12 bit
On-board FIFO	32 MByte, up to 99 frames at full resolution, Mono8/Bayer8, and a <i>GevSCPSPacketSize</i> = 8192 bytes per packet
Mono formats	Mono8, Mono12Packed, Mono12
Color formats	BayerRG8, BayerRG12Packed, BayerGR12, Mono8, RGB8Packed, YUV411Packed, YUV422Packed, YUV444Packed, BGR8Packed, RGBA8Packed, BGRA8Packed
Exposure control	26 μs to 60 s; 1 μs increments
Gain control	0–36 dB
Binning	Horizontal: 1 to 8 columns; Vertical: 1 to 14 rows
Decimation	Horizontal and Vertical: 1, 2, 4, 8 factor
Opto-coupled I/Os	2 input, 2 outputs
RS-232	1 TxD, 1 RxD
Voltage requirements	8–30 VDC, or PoE
Power consumption	3.6 W @ 12 VDC, 4.2 W PoE
Trigger latency*	Idle state: 8.0 μs Frame valid state: 18.7 μs
Trigger jitter*	Idle state: 5.5 μs Frame valid state: 16.2 μs
Operating temperature	+5 °C to +45 °C ambient temperature (without condensation)
Storage temperature	-10 °C to +70 °C ambient temperature (without condensation)
Body dimensions (L x W x H)	86.4 mm x 44 mm x 29 mm including connectors, w/o tripod and lens
Mass	200 g (without lens)
Hardware interface standard	PoE, IEEE 802.3af 1000BASE-T, 100BASE-TX
Software interface standard	GigE Vision Standard 1.2
Camera control interface	GenICam V1.0 compliant
Regulatory	CE, FCC Class B, RoHS (2011/65/EU)
*It is possible to start the exposure of the next frame while the previous frame is read out: <ul style="list-style-type: none"> – Idle state: sensor is ready and camera is idle, waiting for the next trigger – Frame valid state: sensor is reading out and camera is busy. If the next frame is requested by an external trigger in this state, higher latency may occur as compared to the Idle state 	

Table 4: Manta G-032B/C camera specifications

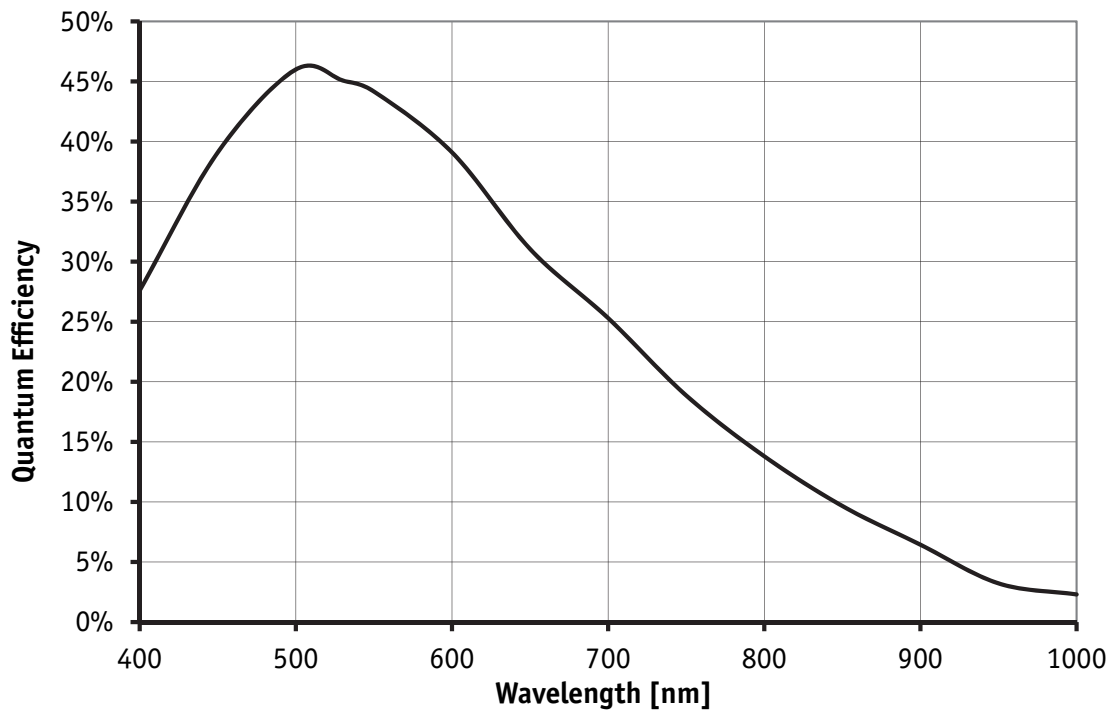

Figure 9: Spectral sensitivity of Manta G-032B (without protection/cover glass)

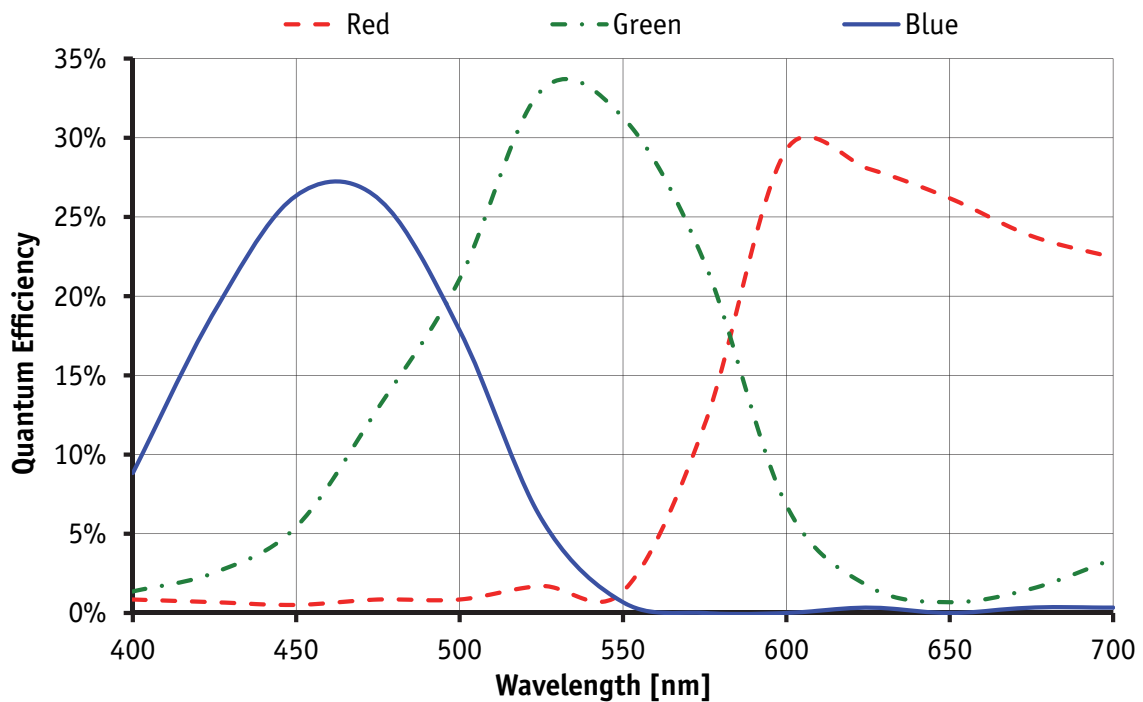

Figure 10: Spectral sensitivity of Manta G-032C (without IR cut filter)

Manta G-033B/C

Feature	Specification
Resolution	656 x 492
Sensor	SONY IT CCD ICX414AL/AQ with HAD microlens
Type	CCD Progressive
Sensor size	Type 1/2
Cell size	9.9 μm
Lens mount	C / CS-Mount
Max frame rate at full resolution	88 fps
Max image bit depth	12 bit
On-board FIFO	32 MByte, up to 99 frames at full resolution, Mono8/Bayer8, and a <i>GevSCPSPacketSize</i> = 8192 bytes per packet
Mono formats	Mono8, Mono12Packed, Mono12
Color formats	BayerRG8, BayerRG12Packed, BayerGR12, Mono8, RGB8Packed, YUV411Packed, YUV422Packed, YUV444Packed, BGR8Packed, RGBA8Packed, BGRA8Packed
Exposure control	26 μs to 60 s; 1 μs increments
Gain control	0–35 dB
Binning	Horizontal: 1 to 8 columns; Vertical: 1 to 14 rows
Decimation	Horizontal and Vertical: 1, 2, 4, 8 factor
Opto-coupled I/Os	2 input, 2 outputs
RS-232	1 TxD, 1 RxD
Voltage requirements	8–30 VDC, or PoE
Power consumption	3.6 W @ 12 VDC, 4.2 W PoE
Trigger latency*	Idle state: 8.6 μs Frame valid state: 19.1 μs
Trigger jitter*	Idle state: 4.8 μs Frame valid state: 15.3 μs
Operating temperature	+5 °C to +45 °C ambient temperature (without condensation)
Storage temperature	-10 °C to +70 °C ambient temperature (without condensation)
Body dimensions (L x W x H)	86.4 mm x 44 mm x 29 mm including connectors, w/o tripod and lens
Mass	200 g (without lens)
Hardware interface standard	PoE, IEEE 802.3af 1000BASE-T, 100BASE-TX
Software interface standard	GigE Vision Standard 1.2
Camera control interface	GenICam V1.0 compliant
Regulatory	CE, FCC Class B, RoHS (2011/65/EU)
<p>*It is possible to start the exposure of the next frame while the previous frame is read out:</p> <ul style="list-style-type: none"> – Idle state: sensor is ready and camera is idle, waiting for the next trigger – Frame valid state: sensor is reading out and camera is busy. If the next frame is requested by an external trigger in this state, higher latency may occur as compared to the Idle state 	

Table 5: Manta G-033B/C camera specifications

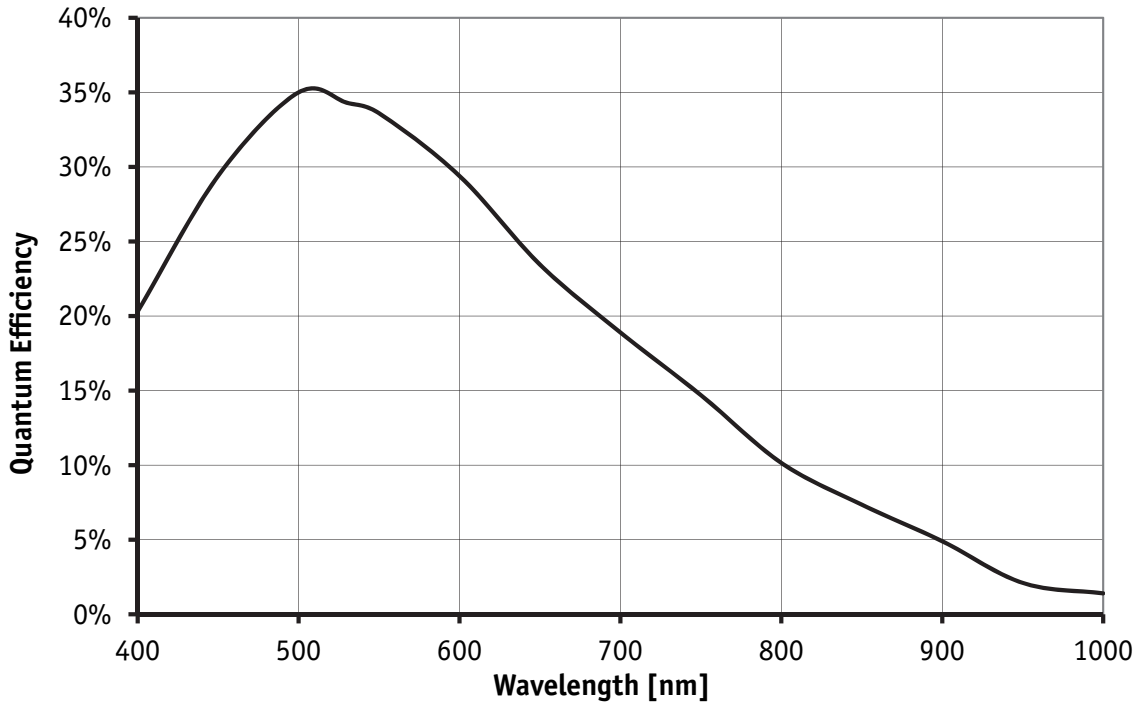

Figure 11: Spectral sensitivity of Manta G-033B (without protection/cover glass)

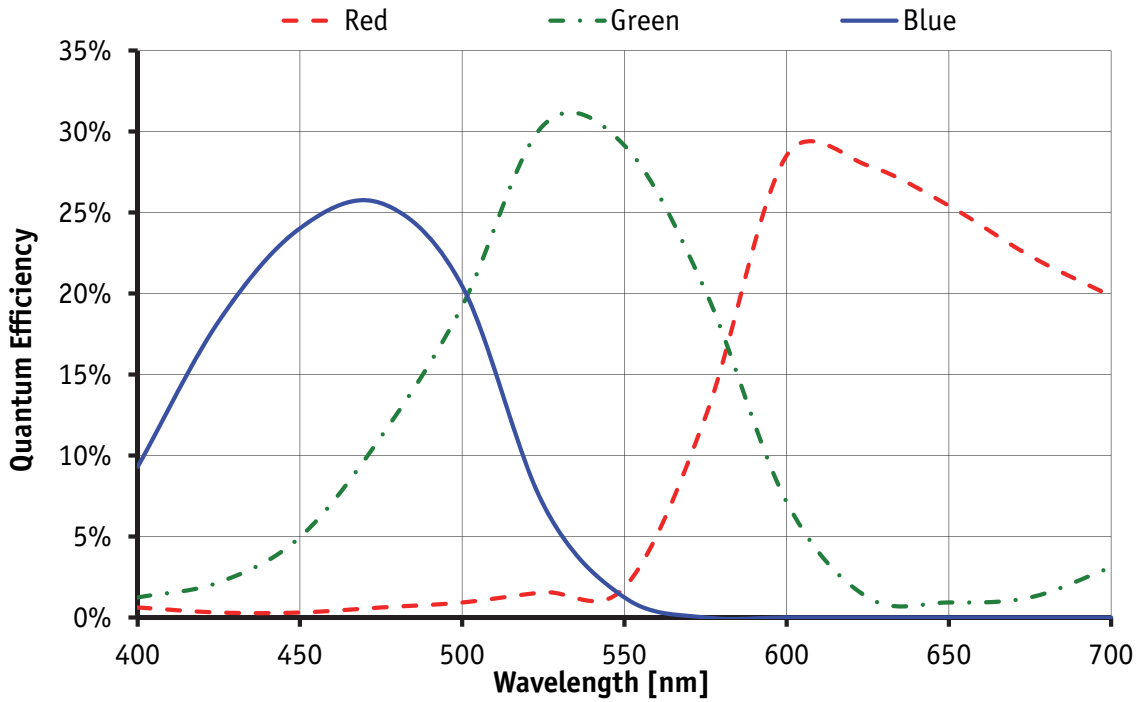

Figure 12: Spectral sensitivity of Manta G-033C (without IR cut filter)

Manta G-046B/C

Feature	Specification
Resolution	780 x 580
Sensor	SONY IT CCD ICX415AL/AQ with HAD microlens
Type	CCD Progressive
Sensor size	Type 1/2
Cell size	8.3 μm
Lens mount	C / CS-Mount
Max frame rate at full resolution	67 fps
Max image bit depth	12 bit
On-board FIFO	32 MByte, up to 70 frames at full resolution, Mono8/Bayer8, and a <i>GevSCPSPacketSize</i> = 8192 bytes per packet
Mono formats	Mono8, Mono12Packed, Mono12
Color formats	BayerRG8, BayerRG12Packed, BayerGR12, Mono8, RGB8Packed, YUV411Packed, YUV422Packed, YUV444Packed, BGR8Packed, RGBA8Packed, BGRA8Packed
Exposure control	26 μs to 60 s; 1 μs increments
Gain control	0–31 dB
Binning	Horizontal: 1 to 8 columns; Vertical: 1 to 14 rows
Decimation	Horizontal and Vertical: 1, 2, 4, 8 factor
Opto-coupled I/Os	2 input, 2 outputs
RS-232	1 TxD, 1 RxD
Voltage requirements	8–30 VDC , or PoE
Power consumption	3.6 W @ 12 VDC, 4.2 W PoE
Trigger latency*	Idle state: 8.8 μs Frame valid state: 20.5 μs
Trigger jitter*	Idle state: 4.9 μs Frame valid state: 16.6 μs
Operating temperature	+5 °C to +45 °C ambient temperature (without condensation)
Storage temperature	-10 °C to +70 °C ambient temperature (without condensation)
Body dimensions (L x W x H)	86.4 mm x 44 mm x 29 mm including connectors, w/o tripod and lens
Mass	200 g (without lens)
Hardware interface standard	PoE, IEEE 802.3af 1000BASE-T, 100BASE-TX
Software interface standard	GigE Vision Standard 1.2
Camera control interface	GenICam V1.0 compliant
Regulatory	CE, FCC Class B, RoHS (2011/65/EU)
<p>*It is possible to start the exposure of the next frame while the previous frame is read out:</p> <ul style="list-style-type: none"> – Idle state: sensor is ready and camera is idle, waiting for the next trigger – Frame valid state: sensor is reading out and camera is busy. If the next frame is requested by an external trigger in this state, higher latency may occur as compared to the Idle state 	

Table 6: Manta G-046B/C camera specifications

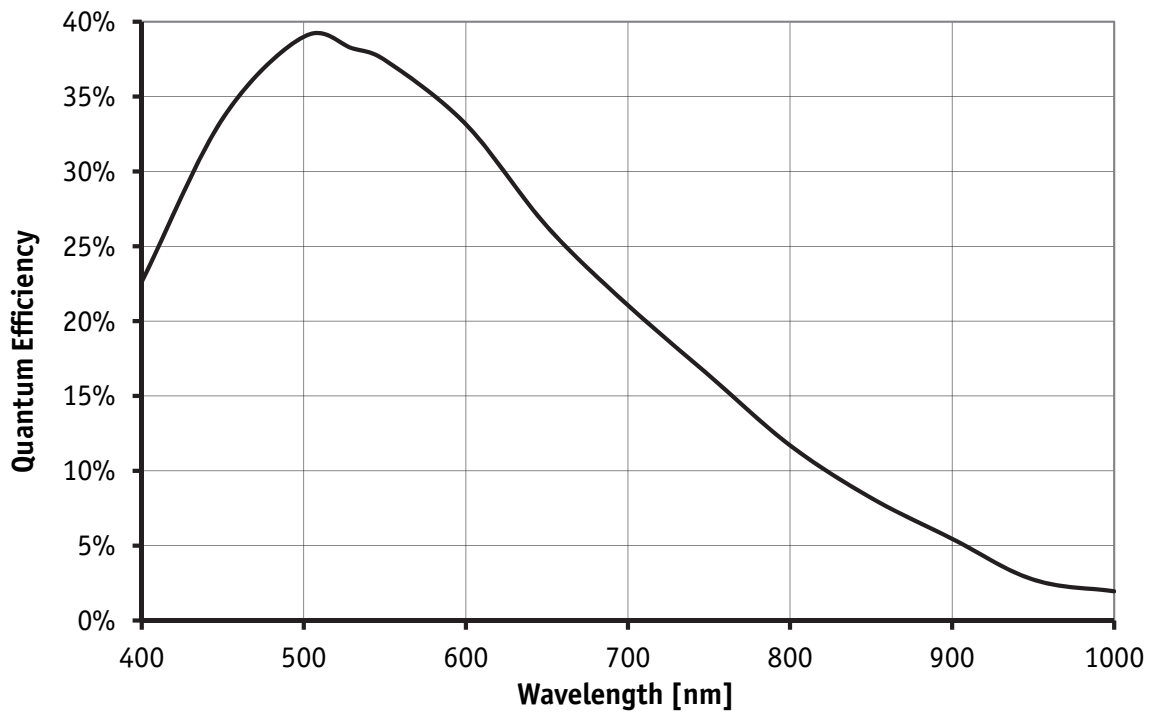

Figure 13: Spectral sensitivity of Manta G-046B (without protection/cover glass)

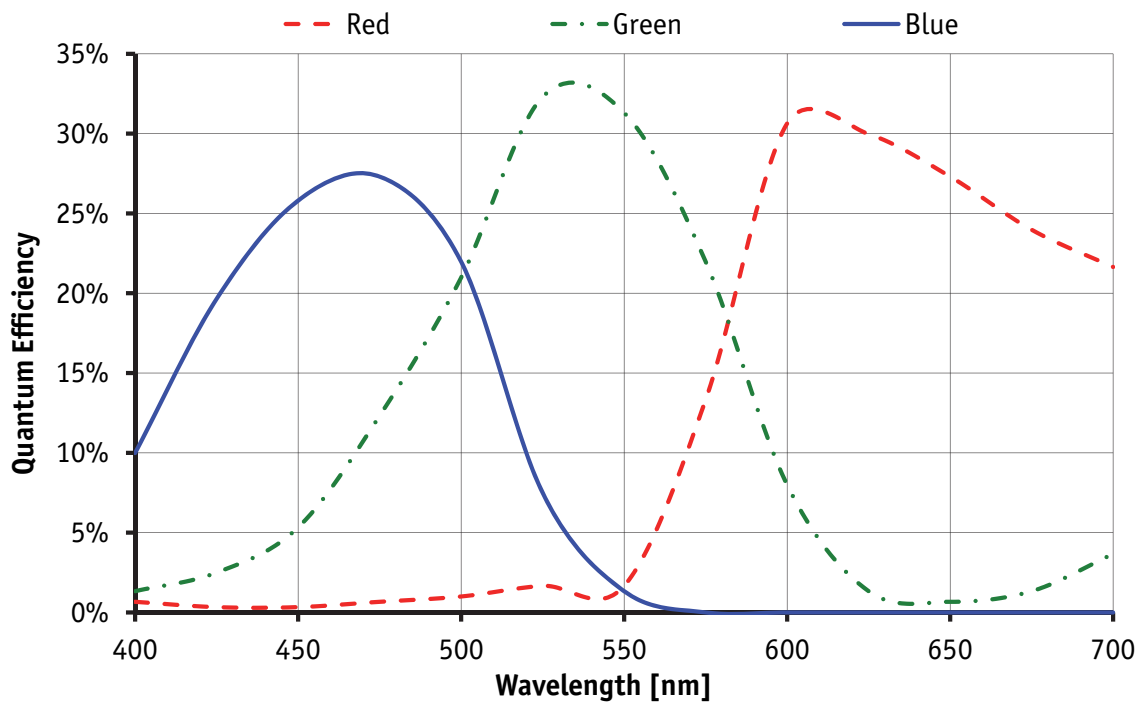

Figure 14: Spectral sensitivity of Manta G-046C (without IR cut filter)

Manta G-095B/C

Feature	Specification
Resolution	1292 x 734
Sensor	SONY IT CCD ICX692AL/AQ with EXview HAD CCD II microlens
Type	CCD Progressive
Sensor size	Type 1/3
Cell size	4.08 μm
Lens mount	C / CS-Mount
Max frame rate at full resolution	40 fps
Max image bit depth	12 bit
On-board FIFO	32 MByte, up to 34 frames at full resolution, Mono8/Bayer8, and a <i>GevSCPSPacketSize</i> = 8192 bytes per packet
Mono formats	Mono8, Mono12Packed, Mono12
Color formats	BayerRG8, BayerRG12Packed, BayerGR12, Mono8, RGB8Packed, YUV411Packed, YUV422Packed, YUV444Packed, BGR8Packed, RGBA8Packed, BGRA8Packed
Exposure control	45 μs to 60 s; 1 μs increments
Gain control	0–32 dB
Binning	Horizontal: 1 to 8 columns; Vertical: 1 to 14 rows
Decimation	Horizontal and Vertical: 1, 2, 4, 8 factor
Opto-coupled I/Os	2 input, 2 outputs
RS-232	1 TxD, 1 RxD
Voltage requirements	8–30 VDC, or PoE
Power consumption	3.6 W @ 12 VDC, 4.2 W PoE
Trigger latency*	Idle state: 12.7 μs Frame valid state: 27.0 μs
Trigger jitter*	Idle state: 6.4 μs Frame valid state: 20.8 μs
Operating temperature	+5 °C to +45 °C ambient temperature (without condensation)
Storage temperature	-10 °C to +70 °C ambient temperature (without condensation)
Body dimensions (L x W x H)	86.4 mm x 44 mm x 29 mm including connectors, w/o tripod and lens
Mass	200 g (without lens)
Hardware interface standard	PoE, IEEE 802.3af 1000BASE-T, 100BASE-TX
Software interface standard	GigE Vision Standard 1.2
Camera control interface	GenICam V1.0 compliant
Regulatory	CE, FCC Class B, RoHS (2011/65/EU)
<p>*It is possible to start the exposure of the next frame while the previous frame is read out:</p> <ul style="list-style-type: none"> – Idle state: sensor is ready and camera is idle, waiting for the next trigger – Frame valid state: sensor is reading out and camera is busy. If the next frame is requested by an external trigger in this state, higher latency may occur as compared to the Idle state 	

Table 7: Manta G-095B/C camera specifications

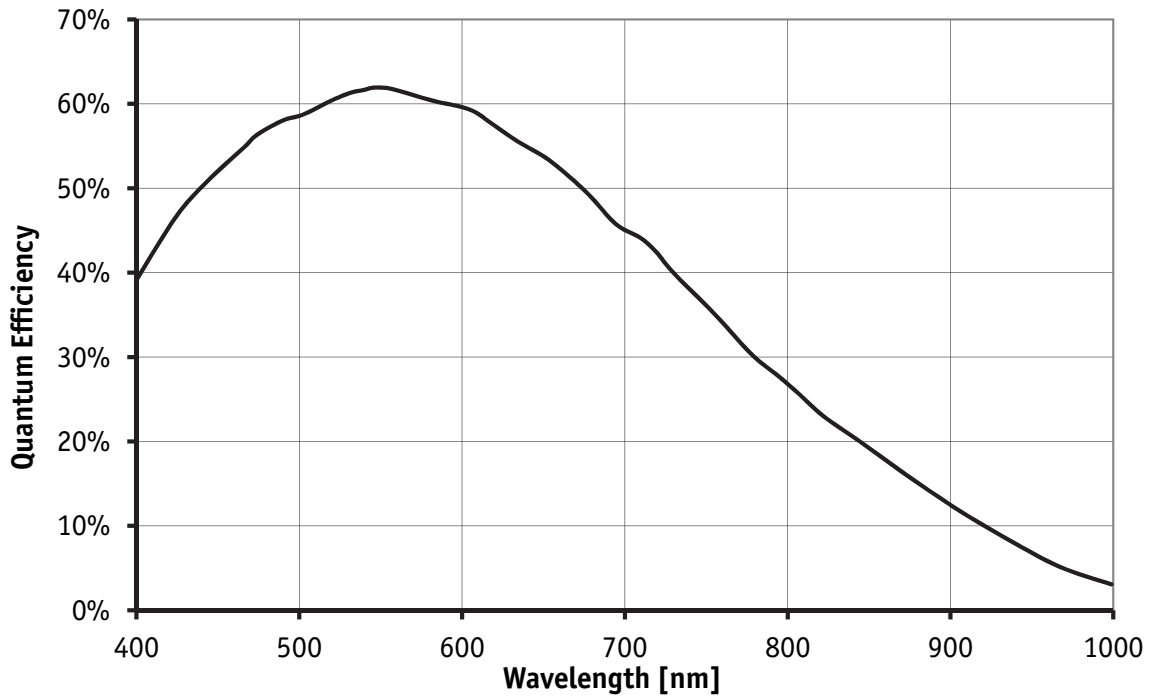

Figure 15: Spectral sensitivity of Manta G-095B (without protection/cover glass)

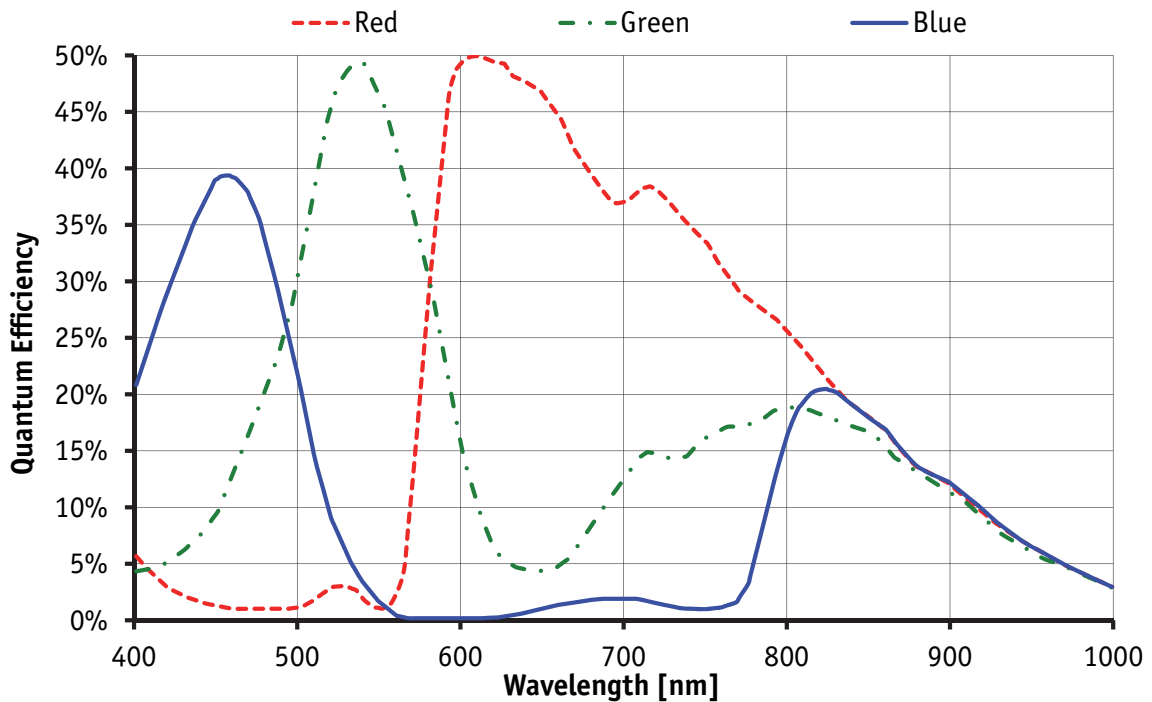

Figure 16: Spectral sensitivity of Manta G-095C (without IR cut filter)

Manta G-125B/C

Feature	Specification
Resolution	1292 x 964
Sensor	SONY IT CCD ICX445ALA/AQA with EXview HAD microlens
Type	CCD Progressive
Sensor size	Type 1/3
Cell size	3.75 μm
Lens mount	C / CS-Mount
Max frame rate at full resolution	30 fps
Max image bit depth	12 bit
On-board FIFO	32 MByte, up to 25 frames at full resolution, Mono8/Bayer8, and a <i>GevSCPSPacketSize</i> = 8192 bytes per packet
Mono formats	Mono8, Mono12Packed, Mono12
Color formats	BayerRG8, BayerRG12Packed, BayerGR12, Mono8, RGB8Packed, YUV411Packed, YUV422Packed, YUV444Packed, BGR8Packed, RGBA8Packed, BGRA8Packed
Exposure control	21 μs to 60 s; 1 μs increments
Gain control	0–31 dB
Binning	Horizontal: 1 to 8 columns; Vertical: 1 to 14 rows
Decimation	Horizontal and Vertical: 1, 2, 4, 8 factor
Opto-coupled I/Os	2 input, 2 outputs
RS-232	1 TxD, 1 RxD
Voltage requirements	8–30 VDC, or PoE
Power consumption	3.6 W @ 12 VDC, 4.2 W PoE
Trigger latency*	Idle state: 12.3 μs Frame valid state: 26.4 μs
Trigger jitter*	Idle state: 6.5 μs Frame valid state: 20.6 μs
Operating temperature	+5 °C to +45 °C ambient temperature (without condensation)
Storage temperature	-10 °C to +70 °C ambient temperature (without condensation)
Body dimensions (L x W x H)	86.4 mm x 44 mm x 29 mm including connectors, w/o tripod and lens
Mass	200 g (without lens)
Hardware interface standard	PoE, IEEE 802.3af 1000BASE-T, 100BASE-TX
Software interface standard	GigE Vision Standard 1.2
Camera control interface	GenICam V1.0 compliant
Regulatory	CE, FCC Class B, RoHS (2011/65/EU)
*It is possible to start the exposure of the next frame while the previous frame is read out: <ul style="list-style-type: none"> – Idle state: sensor is ready and camera is idle, waiting for the next trigger – Frame valid state: sensor is reading out and camera is busy. If the next frame is requested by an external trigger in this state, higher latency may occur as compared to the Idle state 	

Table 8: Manta G-125B/C camera specifications

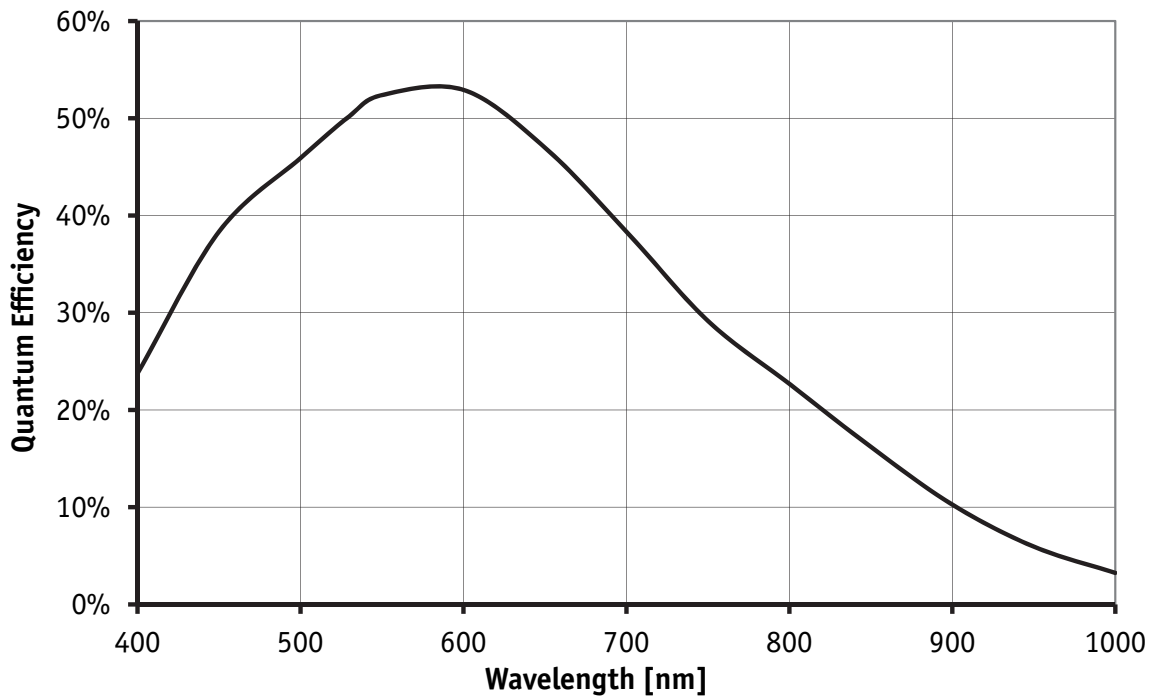

Figure 17: Spectral sensitivity of Manta G-125B (without protection/cover glass)

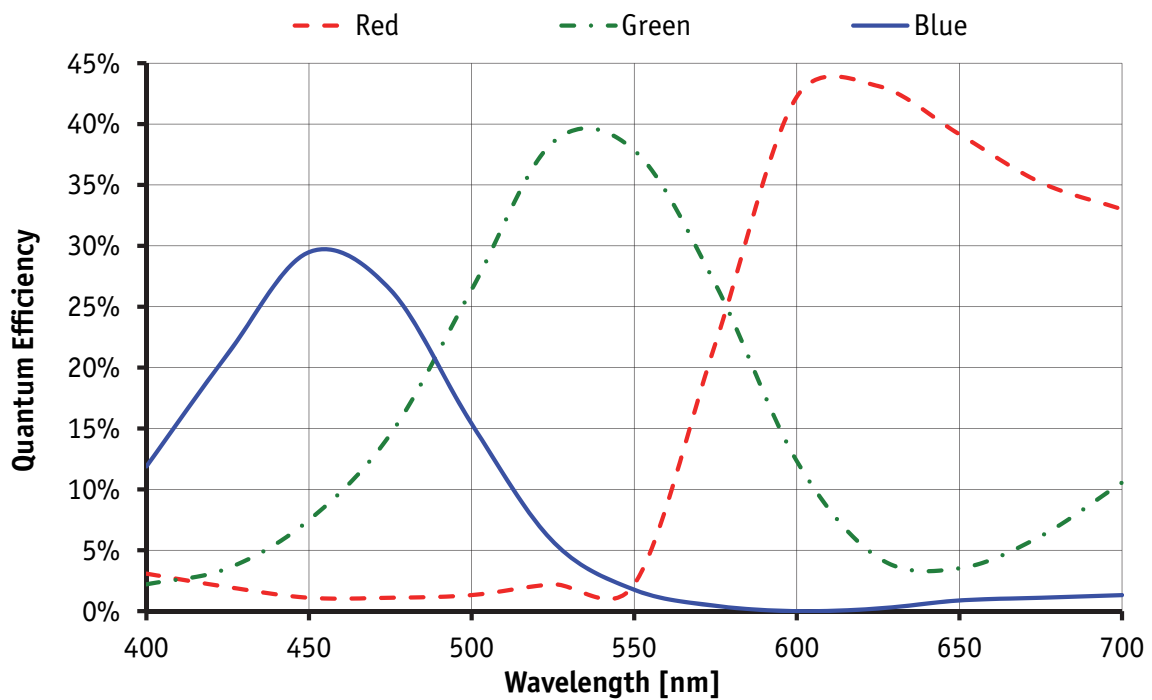

Figure 18: Spectral sensitivity of Manta G-125C (without IR cut filter)

Manta G-145B/C (-30fps)

Feature	Specification
Resolution	1388 x 1038
Sensor	SONY IT CCD ICX285AL/AQ with EXview HAD microlens
Type	CCD Progressive
Sensor size	Type 2/3
Cell size	6.45 μm
Lens mount	C / CS-Mount
Max frame rate at full resolution	G-145B/C: 15 fps; G-145B/C -30fps: 30 fps
Max image bit depth	12 bit
On-board FIFO	32 MByte, up to 22 frames at full resolution, Mono8/Bayer8, and a <i>GevSCP-SPacketSize</i> = 8192 bytes per packet
Mono formats	Mono8, Mono12Packed, Mono12
Color formats	BayerRG8, BayerRG12Packed, BayerRG12, Mono8, RGB8Packed, YUV411Packed, YUV422Packed, YUV444Packed, BGR8Packed, RGBA8Packed, BGRA8Packed
Exposure control	G-145B/C: 43 μs to 60 s; G-145B/C -30fps: 38 μs to 60 s
Gain control	0–33 dB
Binning	Horizontal: 1 to 8 columns; Vertical: 1 to 14 rows
Decimation	Horizontal and Vertical: 1, 2, 4, 8 factor
Opto-coupled I/Os	2 input, 2 outputs
RS-232	1 TxD, 1 RxD
Voltage requirements	8–30 VDC, or PoE
Power consumption	G-145B/C: 3.7 W @ 12 VDC, 4.3 W PoE G-145B/C -30fps: 4.5 W @ 12 VDC, 5.3 W PoE
Trigger latency*	<ul style="list-style-type: none"> • Manta G-145B/C: <ul style="list-style-type: none"> – Idle state: 19.3 μs – Frame valid state: 45.2 μs • Manta G-145B/C-30fps: <ul style="list-style-type: none"> – Idle state: 12.6 μs – Frame valid state: 25.6 μs
Trigger jitter*	<ul style="list-style-type: none"> • Manta G-145B/C: <ul style="list-style-type: none"> – Idle state: 9.8 μs – Frame valid state: 35.7 μs • 145B/C-30fps: <ul style="list-style-type: none"> – Idle state: 6.9 μs – Frame valid state: 19.9 μs
Operating temperature	+5 °C to +45 °C ambient temperature (without condensation)
Storage temperature	-10 °C to +70 °C ambient temperature (without condensation)
Body dimensions (L x W x H)	86.4 mm x 44 mm x 29 mm including connectors, w/o tripod and lens
Mass	200 g (without lens)
Hardware interface standard	PoE, IEEE 802.3af 1000BASE-T, 100BASE-TX
Software interface standard	GigE Vision Standard 1.2
Camera control interface	GenICam V1.0 compliant
Regulatory	CE, FCC Class B, RoHS (2011/65/EU)
*It is possible to start the exposure of the next frame while the previous frame is read out: <ul style="list-style-type: none"> – Idle state: sensor is ready and camera is idle, waiting for the next trigger – Frame valid state: sensor is reading out and camera is busy. If the next frame is requested by an external trigger in this state, higher latency may occur as compared to the Idle state 	

Table 9: Manta G-145B/C (-30fps) camera specifications

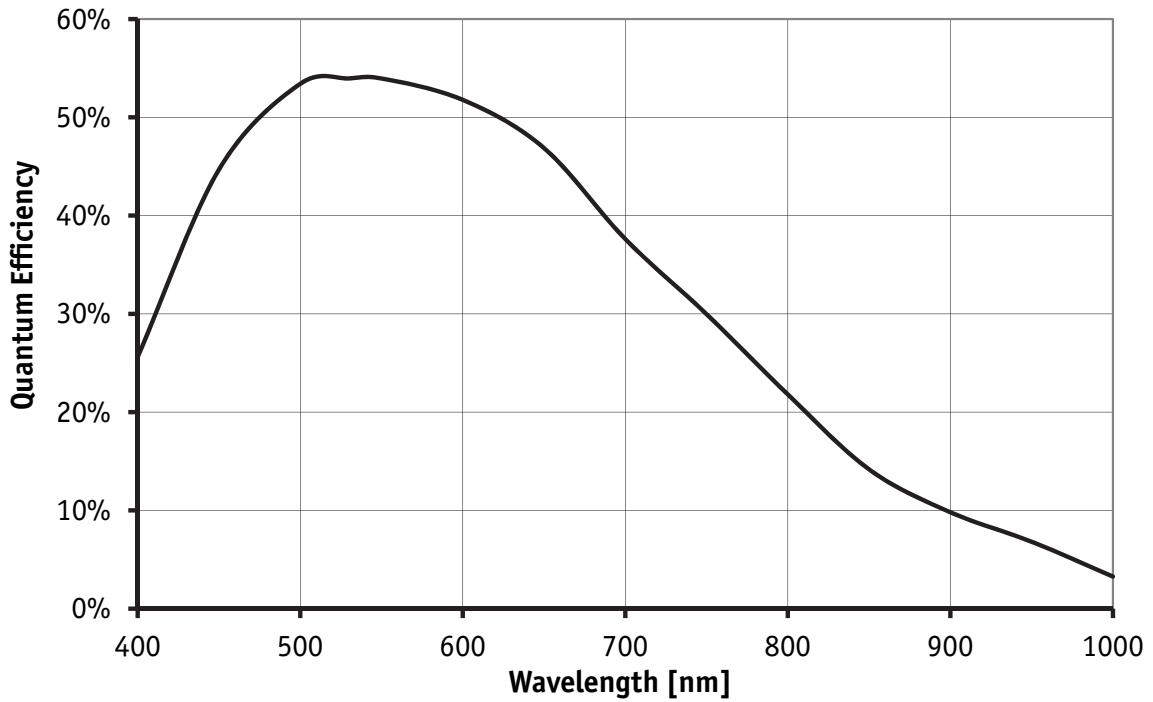

Figure 19: Spectral sensitivity of Manta G-145B (without protection/cover glass)

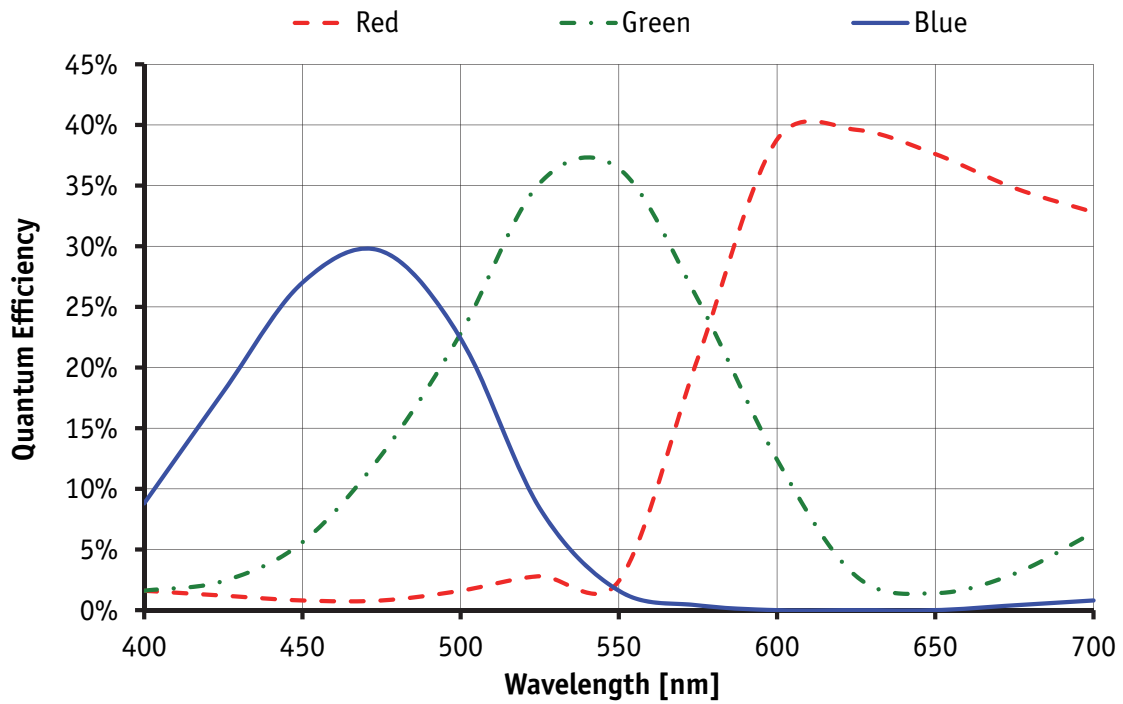

Figure 20: Spectral sensitivity of Manta G-145C (without IR cut filter)

Manta G-145B NIR

Feature	Specification
Resolution	1388 x 1038
Sensor	SONY IT CCD ICX285AL with EXview HAD microlens
Type	CCD Progressive
Sensor size	Type 2/3
Cell size	6.45 μm
Lens mount	C / CS-Mount
Max frame rate at full resolution	15.0 fps (NIR mode: Off/On_Fast) 13.9 fps (NIR mode: On_HighQuality)
Max image bit depth	12 bit
On-board FIFO	32 MByte, up to 22 frames at full resolution, Mono8/Bayer8, and a <i>GevSCPSPacketSize</i> = 8192 bytes per packet
Mono formats	Mono8, Mono12Packed, Mono12
Exposure control	20 μs to 60 s 28 μs to 60 s for NirMode=Off/On_Fast and ExposureMode=External
Gain control	0–33 dB
Binning	Horizontal: 1 to 8 columns; Vertical: 1 to 14 rows
Decimation	Horizontal and Vertical: 1, 2, 4, 8 factor
Opto-coupled I/Os	2 input, 2 outputs
RS-232	1 TxD, 1 RxD
Voltage requirements	8–30 VDC, or PoE
Power consumption	4.2 W @ 12 VDC, 4.9 W PoE
Trigger latency*	Idle state: 58.7 μs Frame valid state: 58.7 μs
Trigger jitter*	Idle state: 35.7 μs Frame valid state: 35.7 μs
Operating temperature	+5 °C to +45 °C ambient temperature (without condensation)
Storage temperature	-10 °C to +70 °C ambient temperature (without condensation)
Body dimensions (L x W x H)	86.4 mm x 44 mm x 29 mm including connectors, w/o tripod and lens
Mass	200 g (without lens)
Hardware interface standard	PoE, IEEE 802.3af 1000BASE-T, 100BASE-TX
Software interface standard	GigE Vision Standard 1.2
Camera control interface	GenICam V1.0 compliant
Regulatory	CE, FCC Class B, RoHS (2011/65/EU)
*It is possible to start the exposure of the next frame while the previous frame is read out: <ul style="list-style-type: none"> – Idle state: sensor is ready and camera is idle, waiting for the next trigger – Frame valid state: sensor is reading out and camera is busy. If the next frame is requested by an external trigger in this state, higher latency may occur as compared to the Idle state 	

Table 10: Manta G-145 B NIR camera specifications

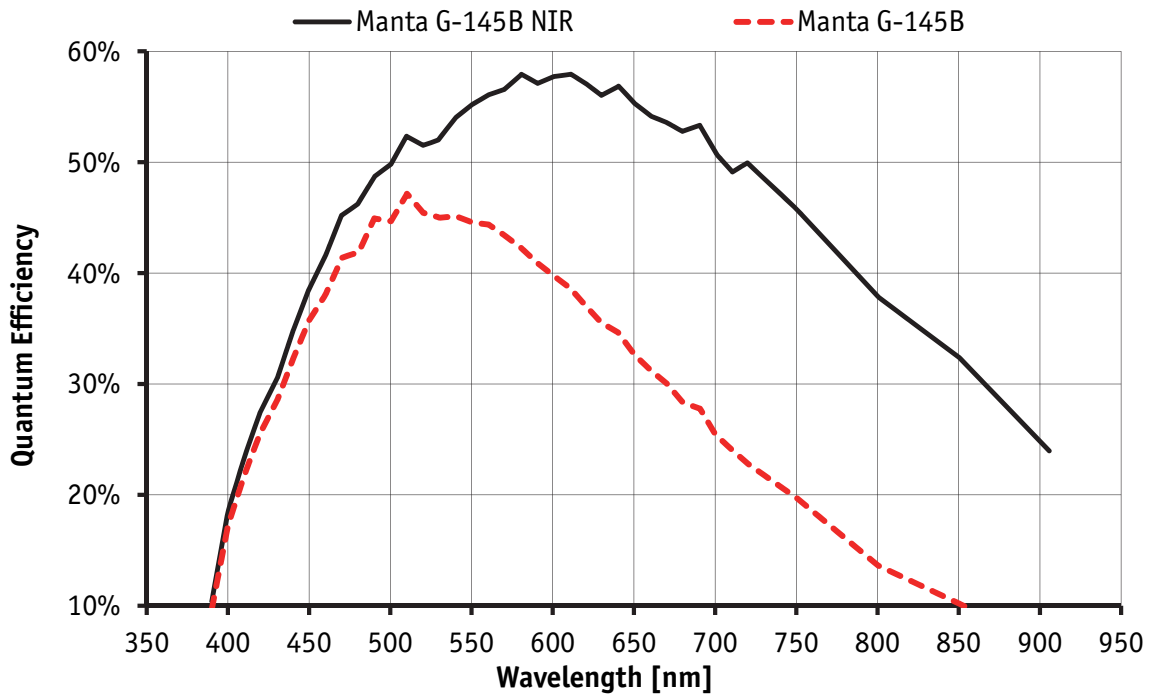

Figure 21: Spectral sensitivity of Manta G-145B NIR (NirMode=On_Fast or On_HighQuality) compared to Manta G-145B

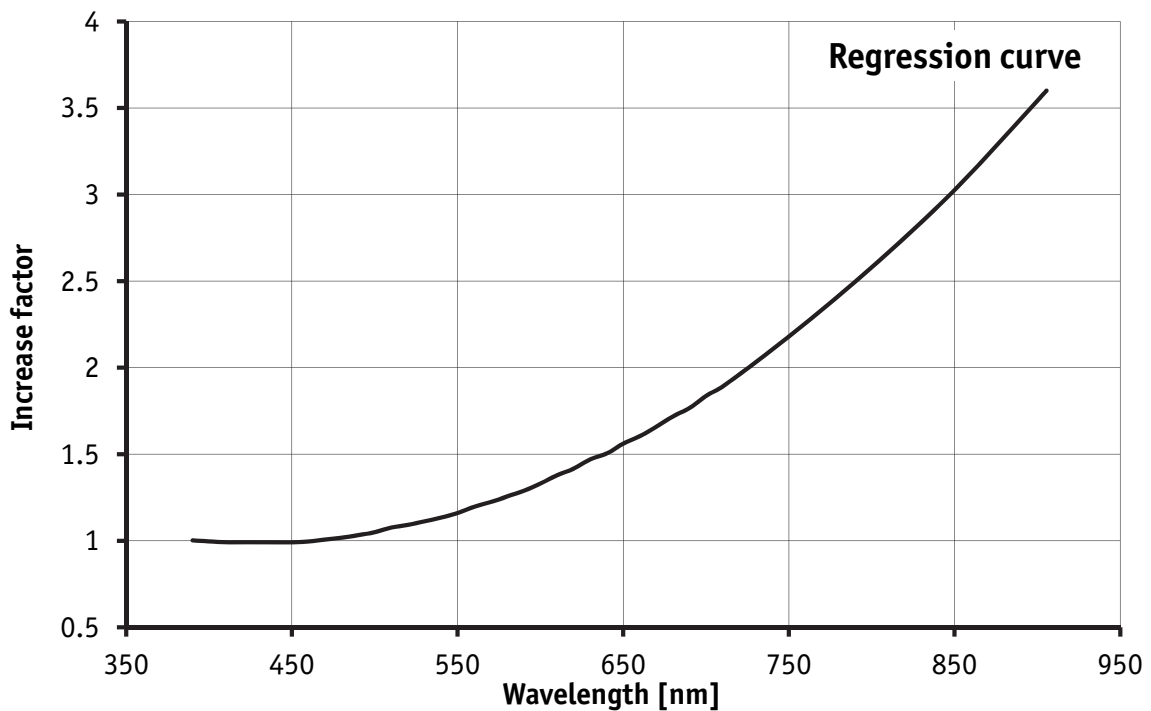

Figure 22: Increase of relative response for Manta G-145B NIR with NIR mode set to On_HighQuality

Manta G-146B/C

Feature	Specification
Resolution	1388 x 1038
Sensor	SONY IT CCD ICX267AL/AK with HAD microlens
Type	CCD Progressive
Sensor size	Type 1/2
Cell size	4.65 μm
Lens mount	C / CS-Mount
Max frame rate at full resolution	17 fps
Max image bit depth	12 bit
On-board FIFO	32 MByte, up to 22 frames at full resolution, Mono8/Bayer8, and a <i>GevSCPSPacketSize</i> = 8192 bytes per packet
Mono formats	Mono8, Mono12Packed, Mono12
Color formats	BayerGB8, BayerGB12Packed, BayerGB12, Mono8, RGB8Packed, YUV411Packed, YUV422Packed, YUV444Packed, BGR8Packed, RGBA8Packed, BGRA8Packed
Exposure control	31 μs to 60 s; 1 μs increments
Gain control	0–33 dB
Binning	Horizontal: 1 to 8 columns; Vertical: 1 to 14 rows
Decimation	Horizontal and Vertical: 1, 2, 4, 8 factor
Opto-coupled I/Os	2 input, 2 outputs
RS-232	1 TxD, 1 RxD
Voltage requirements	8–30 VDC, or PoE
Power consumption	3.6 W @ 12 VDC, 4.2 W PoE
Trigger latency*	Idle state: 21.1 μs Frame valid state: 42.7 μs
Trigger jitter*	Idle state: 9.2 μs Frame valid state: 30.8 μs
Operating temperature	+5 °C to +45 °C ambient temperature (without condensation)
Storage temperature	-10 °C to +70 °C ambient temperature (without condensation)
Body dimensions (L x W x H)	86.4 mm x 44 mm x 29 mm including connectors, w/o tripod and lens
Mass	200 g (without lens)
Hardware interface standard	PoE, IEEE 802.3af 1000BASE-T, 100BASE-TX
Software interface standard	GigE Vision Standard 1.2
Camera control interface	GenICam V1.0 compliant
Regulatory	CE, FCC Class B, RoHS (2011/65/EU)
*It is possible to start the exposure of the next frame while the previous frame is read out: <ul style="list-style-type: none"> – Idle state: sensor is ready and camera is idle, waiting for the next trigger – Frame valid state: sensor is reading out and camera is busy. If the next frame is requested by an external trigger in this state, higher latency may occur as compared to the Idle state 	

Table 11: Manta G-146B/C camera specifications

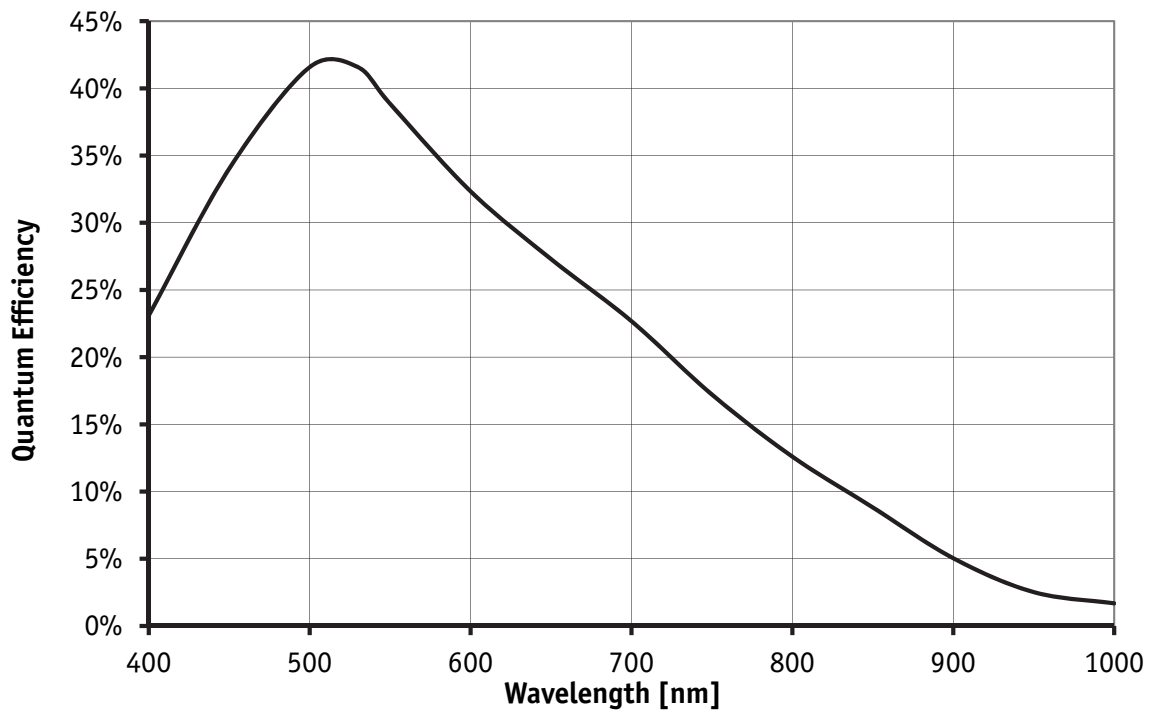

Figure 23: Spectral sensitivity of Manta G-146B (without protection/cover glass)

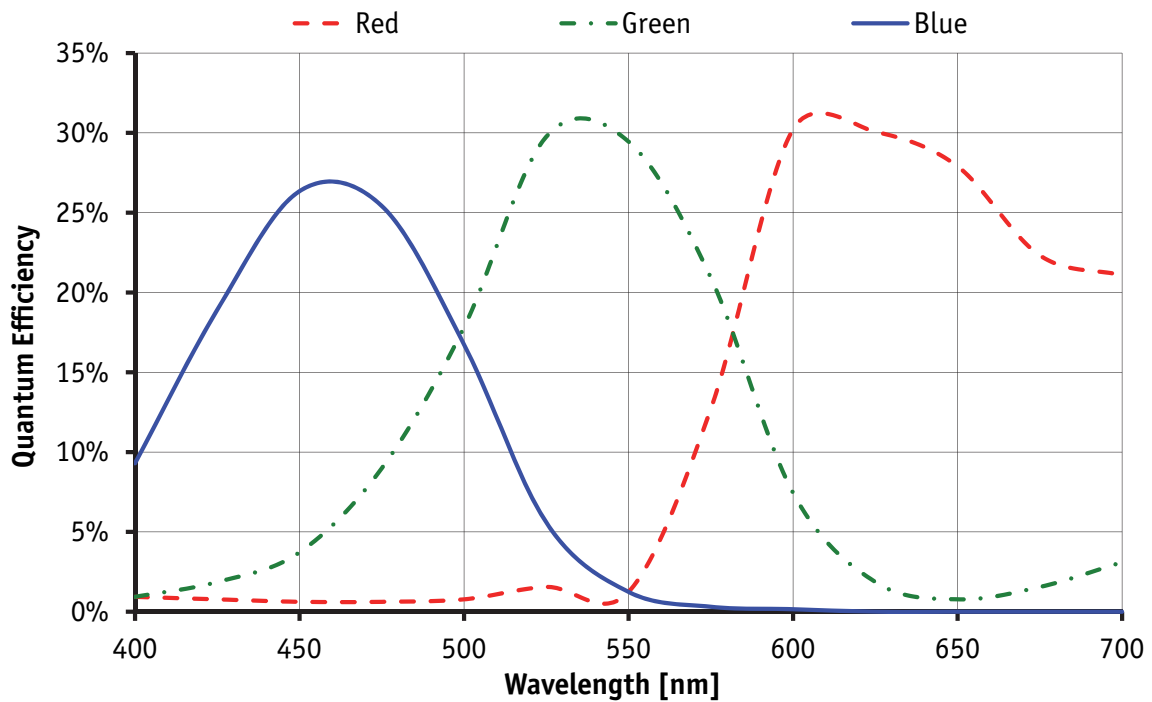

Figure 24: Spectral sensitivity of Manta G-146C (without IR cut filter)

Manta G-201B/C (-30fps)

Feature	Specification
Resolution	1624 x 1234
Sensor	SONY IT CCD ICX274AL/AQ with ExView HAD microlens
Type	CCD Progressive
Sensor size	Type 1/1.8
Cell size	4.4 μm
Lens mount	C / CS-Mount
Max frame rate at full resolution	G-201B/C: 14 fps; G-201B/C -30fps: 30 fps
Max image bit depth	12 bit
On-board FIFO	32 MByte, up to 16 frames at full resolution, Mono8/Bayer8, and a <i>GevSCP-SPacketSize</i> = 8192 bytes per packet
Mono formats	Mono8, Mono12Packed, Mono12
Color formats	BayerRG8, BayerRG12Packed, BayerRG12, Mono8, RGB8Packed, YUV411Packed, YUV422Packet, YUV444Packed, BGR8Packed, RGBA8Packed (not -30fps), BGRA8Packed (not -30fps)
Exposure control	G-201B/C: 51 μs to 60 s; G-201B/C -30fps: 10 μs to 60 s
Gain control	0–31 dB
Binning	Horizontal: 1 to 8 columns; Vertical: 1 to 14 rows
Decimation	Horizontal and Vertical: 1, 2, 4, 8 factor
Opto-coupled I/Os	2 input, 2 outputs
RS-232	1 Tx, 1 Rx
Voltage requirements	8–30 VDC, or PoE
Power consumption	G-201B/C: 3.6 W @ 12 VDC, 4.2 W PoE G-201B/C -30fps: 4.6 W @ 12 VDC, 5.4 W PoE
Trigger latency*	<ul style="list-style-type: none"> • Manta G-201B/C: <ul style="list-style-type: none"> – Idle state: 17.0 μs – Frame valid state: 40.8 μs • Manta G-201B/C-30fps: <ul style="list-style-type: none"> – Idle state: 9.4 μs – Frame valid state: 21.4 μs
Trigger jitter*	<ul style="list-style-type: none"> • Manta G-201B/C: <ul style="list-style-type: none"> – Idle state: 7.6 μs – Frame valid state: 31.4 μs • Manta G-201B/C-30fps: <ul style="list-style-type: none"> – Idle state: 5.4 μs – Frame valid state: 17.4 μs
Operating temperature	+5 °C to +45 °C ambient temperature (without condensation)
Storage temperature	-10 °C to +70 °C ambient temperature (without condensation)
Body dimensions (L x W x H)	86.4 mm x 44 mm x 29 mm including connectors, w/o tripod and lens
Mass	200 g (without lens)
Hardware interface standard	PoE, IEEE 802.3af 1000BASE-T, 100BASE-TX
Software interface standard	GigE Vision Standard 1.2
Camera control interface	GenICam V1.0 compliant
Regulatory	CE, FCC Class B, RoHS (2011/65/EU)
*It is possible to start the exposure of the next frame while the previous frame is read out: <ul style="list-style-type: none"> – Idle state: sensor is ready and camera is idle, waiting for the next trigger – Frame valid state: sensor is reading out and camera is busy. If the next frame is requested by an external trigger in this state, higher latency may occur as compared to the Idle state 	

Table 12: Manta G-201B/C (-30fps) camera specifications

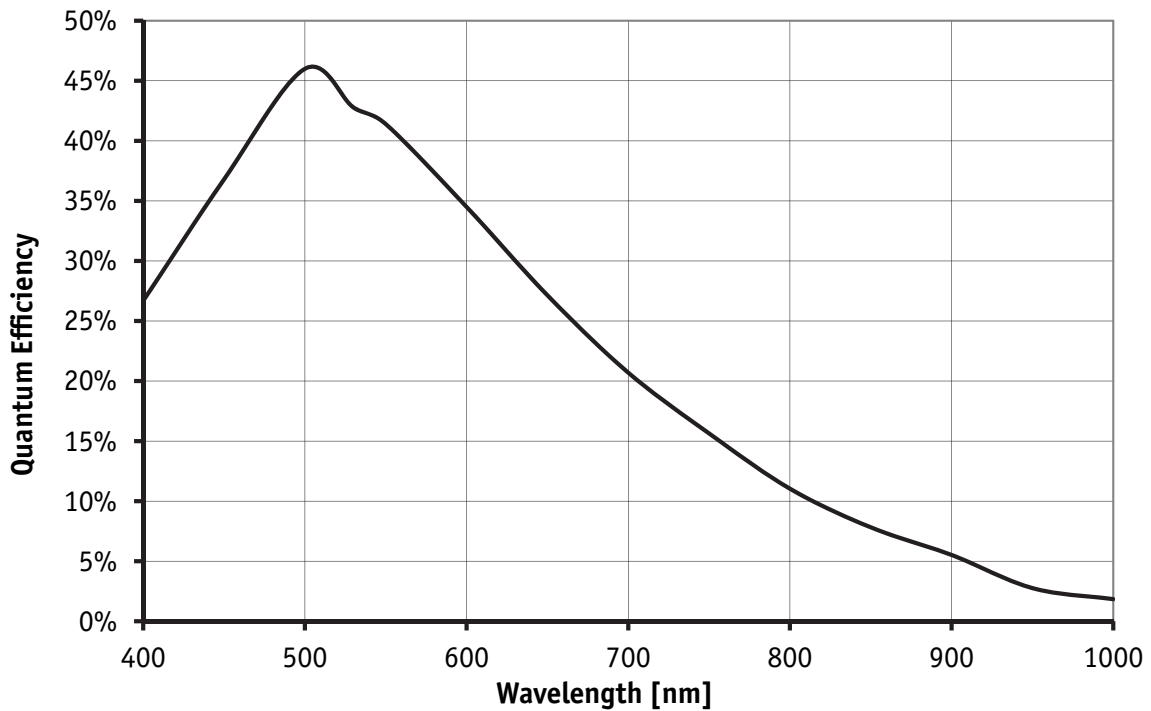

Figure 25: Spectral sensitivity of Manta G-201B (without protection/cover glass)

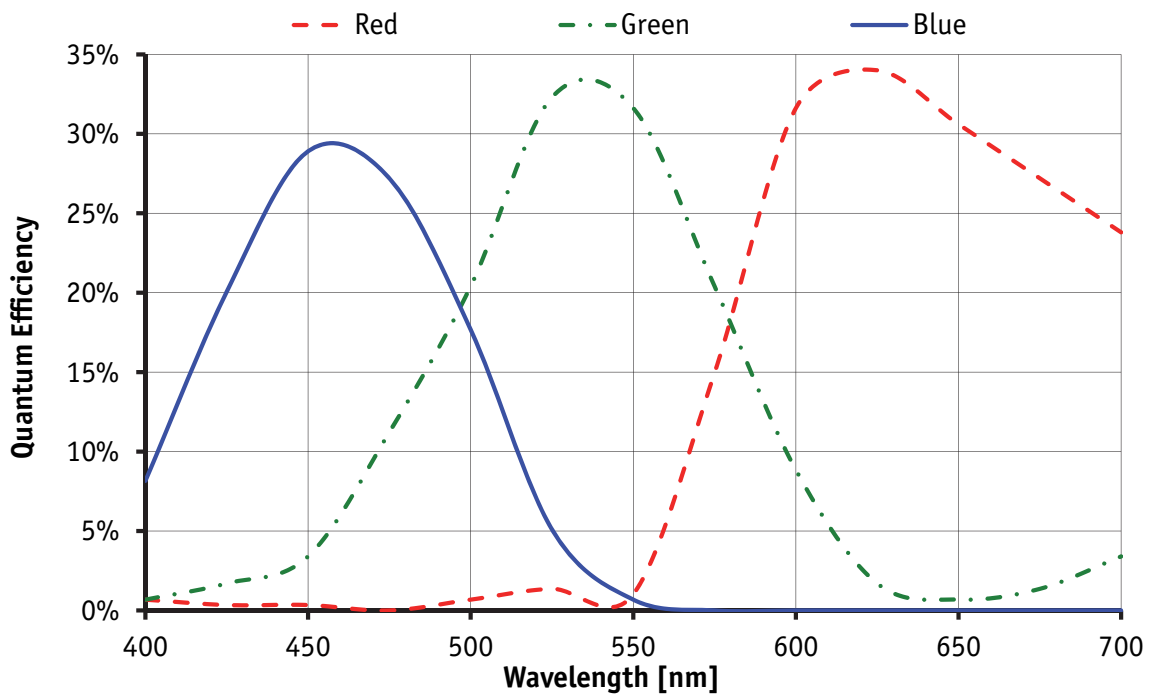

Figure 26: Spectral sensitivity of Manta G-201C (without IR cut filter)

Manta G-223B/C (NIR)

Feature	Specification
Resolution	2048 x 1088
Sensor	CMOSIS CMV2000 with microlenses and global shutter
Type	CMOS
Sensor size	Type 2/3
Cell size	5.5 μm
Lens mount	C-Mount
Max frame rate at full resolution	53.7 fps @ 124 MB/s; 60.1 burst mode*
Max image bit depth	12 bit
On-board FIFO	128 MByte, up to 59 frames at full resolution, Mono8/Bayer8, and a <i>GevSCPSPacketSize</i> = 8192 bytes per packet
Mono formats	Mono8, Mono12Packed, Mono12
Color formats	BayerGB8, BayerGB12Packed, BayerGB12, Mono8, RGB8Packed, BGR8Packed, RGBA8Packed, BGRA8Packed, YUV411Packed, YUV422Packed, YUV444Packed
Exposure control	18 μs [†] to 126 s; 1 μs increments
Gain control	0–26 dB
Binning	N/A
Decimation	Horizontal and Vertical: 1, 2, 4, 8 factor
Opto-coupled I/Os	2 input, 2 outputs
RS-232	1 TxD, 1 RxD
Voltage requirements	8–30 VDC, or PoE
Power consumption	2.7 W @ 12 VDC, 3.1 W PoE
Operating temperature	+5 °C to +45 °C ambient temperature (without condensation)
Storage temperature	-10 °C to +70 °C ambient temperature (without condensation)
Body dimensions (L x W x H)	86.4 mm x 44 mm x 29 mm including connectors, w/o tripod and lens
Mass	150 g (without lens)
Hardware interface standard	PoE, IEEE 802.3af 1000BASE-T, 100BASE-TX
Software interface standard	GigE Vision Standard 1.2
Camera control interface	GenICam V1.0 compliant
Regulatory	CE, FCC Class B, RoHS (2011/65/EU)
*See <i>StreamFrameRateConstrain</i> in GigE Features Reference document.	
[†] Camera firmware v1.52.8151 shows minimum exposure values without frame overhead time, i.e., 1 μs . See sensor datasheet for details on frame overhead time. This will be fixed in the next firmware release.	

Table 13: Manta G-223B/C (NIR) camera specifications

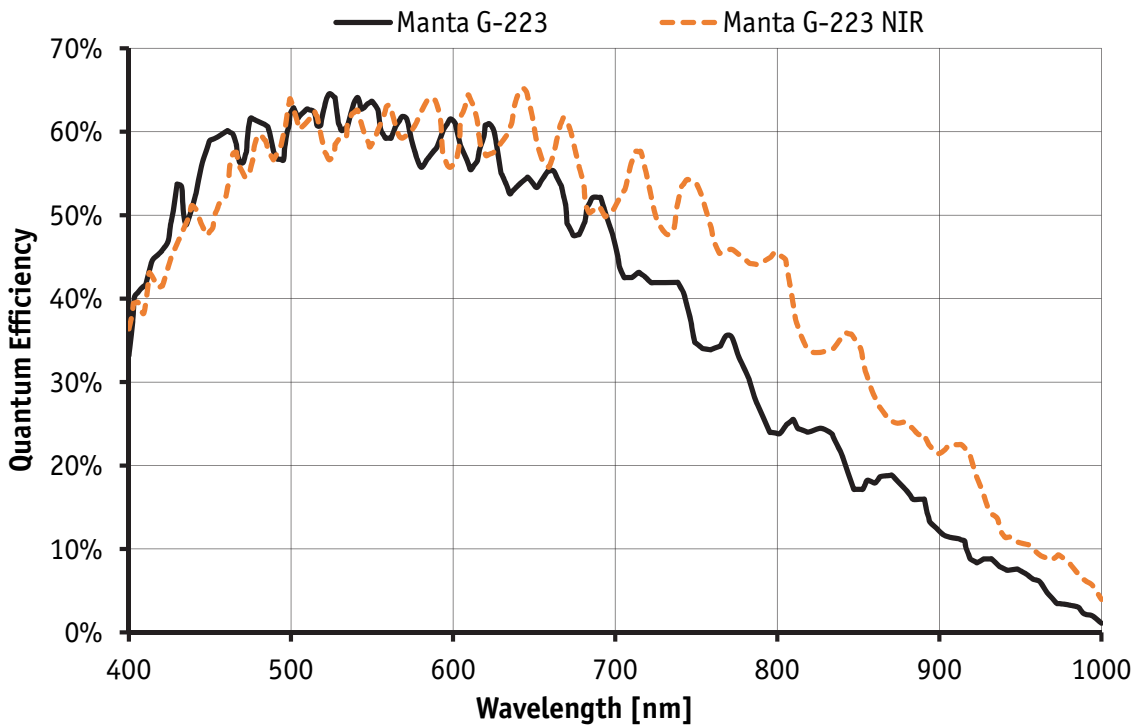

Figure 27: Spectral sensitivity of Manta G-223B (NIR)

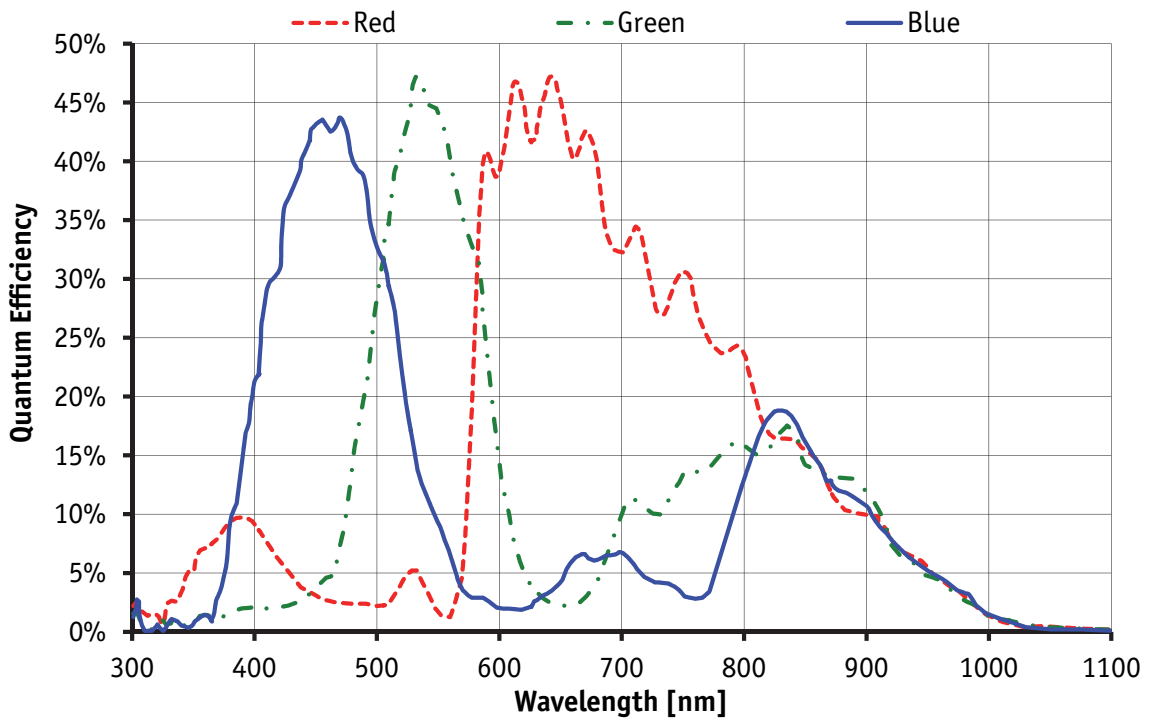

Figure 28: Spectral sensitivity of Manta G-223C (without IR cut filter)

Manta G-235B/C

Feature	Specification
Resolution	1936 x1216
Sensor	SONY IMX174LLJ/IMX174LQJ with global shutter
Type	CMOS Progressive
Sensor size	Type 1/1.2
Cell size	5.86 μm
Lens mount	C-Mount
Max frame rate at full resolution	50.7 fps @ 124 MB/s; 55.8 fps burst mode [†]
Max image bit depth	12 bit
On-board FIFO	128 MByte, up to 56 frames at full resolution, Mono8/Bayer8, and a <i>GevSCPSPacketSize</i> = 8192 bytes per packet
Mono formats	Mono8, Mono12Packed, Mono12
Color formats	Mono8, BayerRG8, BayerRG12, RGB8Packed, BGR8Packed, YUV411Packed, YUV422Packed, YUV444Packed
Exposure control	Manta G-235B: 28 μs to 60 s Manta G-235C: <ul style="list-style-type: none"> • Mono8, BayerRG8, BayerRG12, YUV411Packed, YUV422Packed: 28 μs to 88 s, 14 μs increments • RGB8Packed, BGR8Packed, YUV444Packed: 56 μs to 88 s, 28 μs increments
Gain control	0–40 dB
Binning	Horizontal: 1 to 4 pixels; Vertical: 1 to 4 rows
Decimation	Horizontal and Vertical: 1, 2, 4, 8 factor
Opto-coupled I/Os	2 input, 2 outputs
RS-232	1 TxD, 1 RxD
Voltage requirements	8–30 VDC, or PoE
Power consumption	2.8 W @ 12 VDC, 3.3 W PoE
Trigger latency*	28.6 μs
Trigger jitter*	7.2 μs
Operating temperature	+5 °C to +45 °C ambient temperature (without condensation)
Storage temperature	-10 °C to +70 °C ambient temperature (without condensation)
Body dimensions (L x W x H)	86.4 mm x 44 mm x 29 mm including connectors, w/o tripod and lens
Mass	150 g (without lens)
Hardware interface standard	PoE, IEEE 802.3af 1000BASE-T, 100BASE-TX
Software interface standard	GigE Vision Standard 1.2
Camera control interface	GenICam V1.0 compliant
Regulatory	CE, FCC Class B, RoHS (2011/65/EU)
[†] See <i>StreamFrameRateConstrain</i> in GigE Features Reference document. *These values are calculated directly from the microcontroller source. These values are only valid for pixel formats < 16 bit per pixel and applicable in both Idle and Frame valid state: <ul style="list-style-type: none"> – Idle state: sensor is ready and camera is idle, waiting for the next trigger – Frame valid state: sensor is reading out and camera is busy. If the next frame is requested by an external trigger in this state, higher latency may occur as compared to the Idle state 	

Table 14: Manta G-235B/C camera specifications

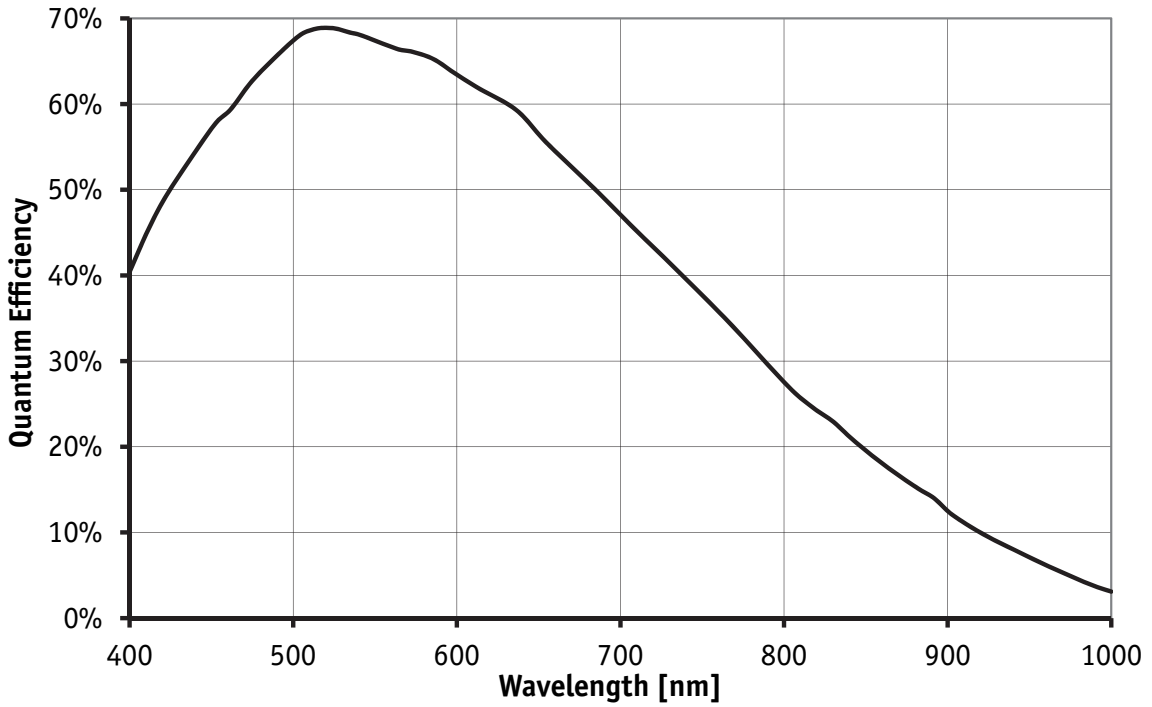

Figure 29: Spectral sensitivity of Manta G-235B (without protection/cover glass)

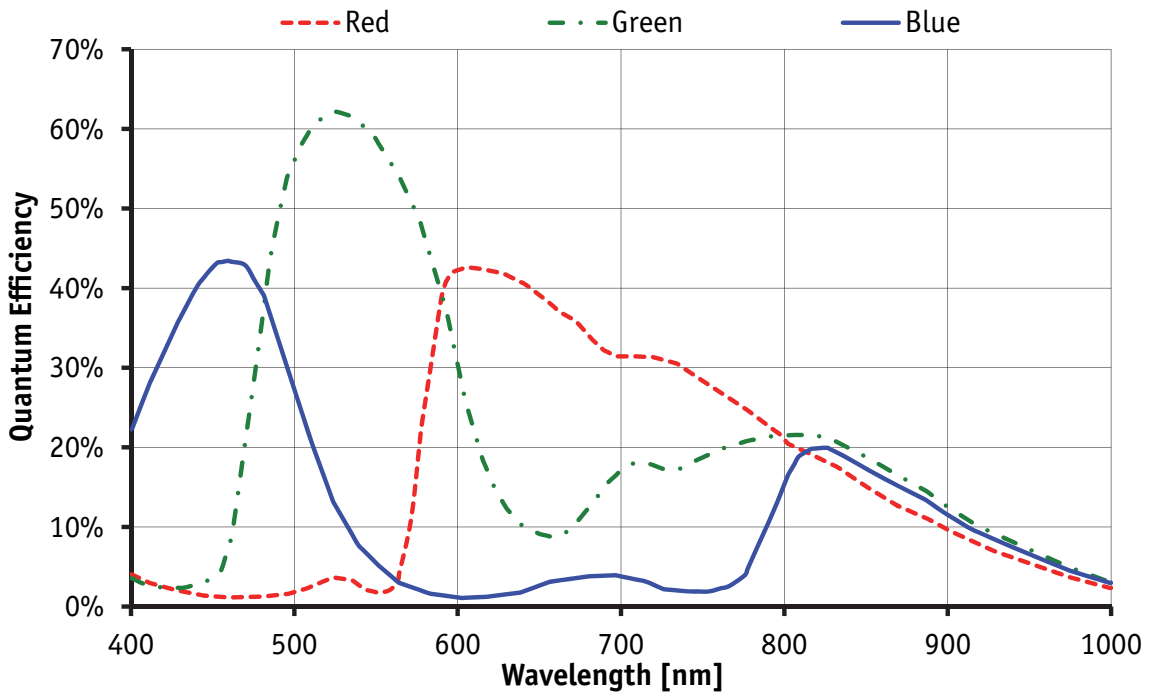

Figure 30: Spectral sensitivity of Manta G-235C (without IR cut filter)

Manta G-282B/C

Feature	Specification
Resolution	1936 x 1458
Sensor	SONY IT CCD ICX687ALA/AQA with EXview HAD II microlens
Type	CCD Progressive
Sensor size	Type 1/1.8
Cell size	3.69 μm
Lens mount	C-Mount
Max frame rate at full resolution	30 fps
Max image bit depth	12 bit
On-board FIFO	128 MByte, up to 47 frames at full resolution, Mono8/Bayer8, and a <i>GevSCPSPacketSize</i> = 8192 bytes per packet
Mono formats	Mono8, Mono12Packed, Mono12
Color formats	BayerRG8, BayerRG12Packed, BayerRG12, Mono8, RGB8Packed, YUV411Packed, YUV422Packed, YUV444Packed, BGR8Packed
Exposure control	41 μs to 38 s; 1 μs increments
Gain control	0–32 dB
Binning	Horizontal: 1 to 8 columns; Vertical: 1 to 14 rows
Decimation	Horizontal and Vertical: 1, 2, 4, 8 factor
Opto-coupled I/Os	2 input, 2 outputs
RS-232	1 TxD, 1 RxD
Voltage requirements	8–30 VDC, or PoE
Power consumption	3.5 W @ 12 VDC, 4.1 W PoE
Trigger latency*	Idle state: 7.2 μs Frame valid state: 18.4 μs
Trigger jitter*	Idle state: 4.0 μs Frame valid state: 15.2 μs
Operating temperature	+5 °C to +45 °C ambient temperature (without condensation)
Storage temperature	-10 °C to +70 °C ambient temperature (without condensation)
Body dimensions (L x W x H)	86.4 mm x 44 mm x 29 mm including connectors, w/o tripod and lens
Mass	150 g (without lens)
Hardware interface standard	PoE, IEEE 802.3af 1000BASE-T, 100BASE-TX
Software interface standard	GigE Vision Standard 1.2
Camera control interface	GenICam V1.0 compliant
Regulatory	CE, FCC Class B, RoHS (2011/65/EU)
<p>*It is possible to start the exposure of the next frame while the previous frame is read out:</p> <ul style="list-style-type: none"> – Idle state: sensor is ready and camera is idle, waiting for the next trigger – Frame valid state: sensor is reading out and camera is busy. If the next frame is requested by an external trigger in this state, higher latency may occur as compared to the Idle state 	

Table 15: Manta G-282B/C camera specifications

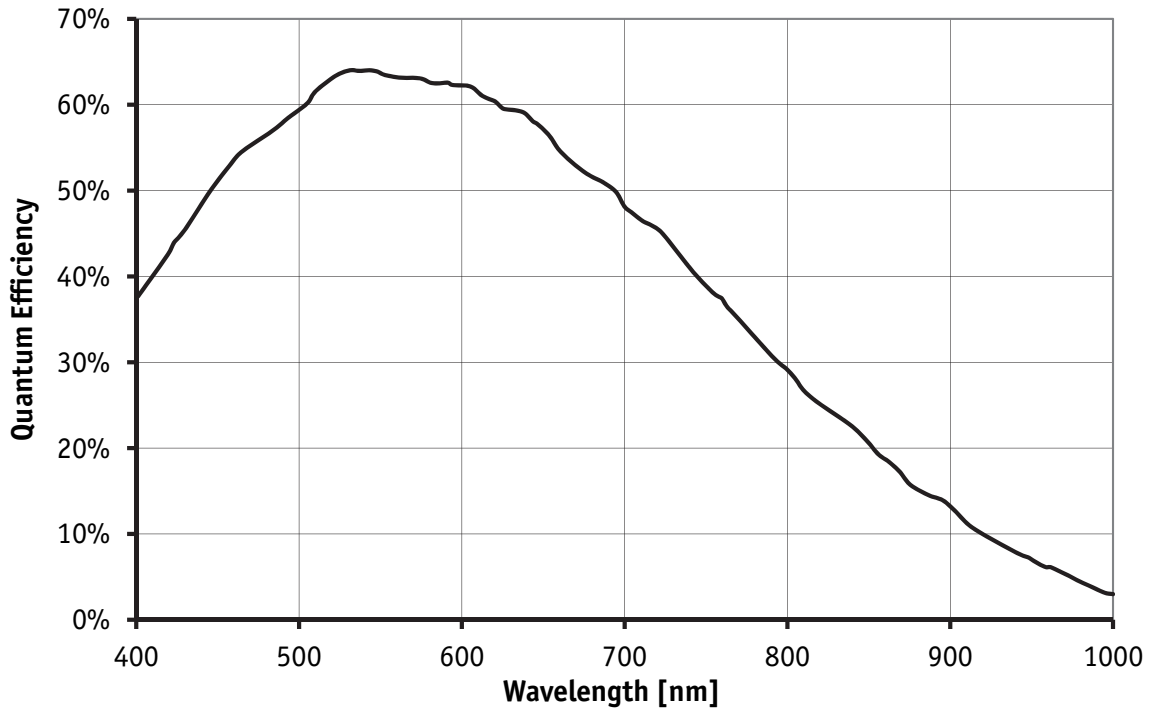

Figure 31: Spectral sensitivity of Manta G-282B (without protection/cover glass)

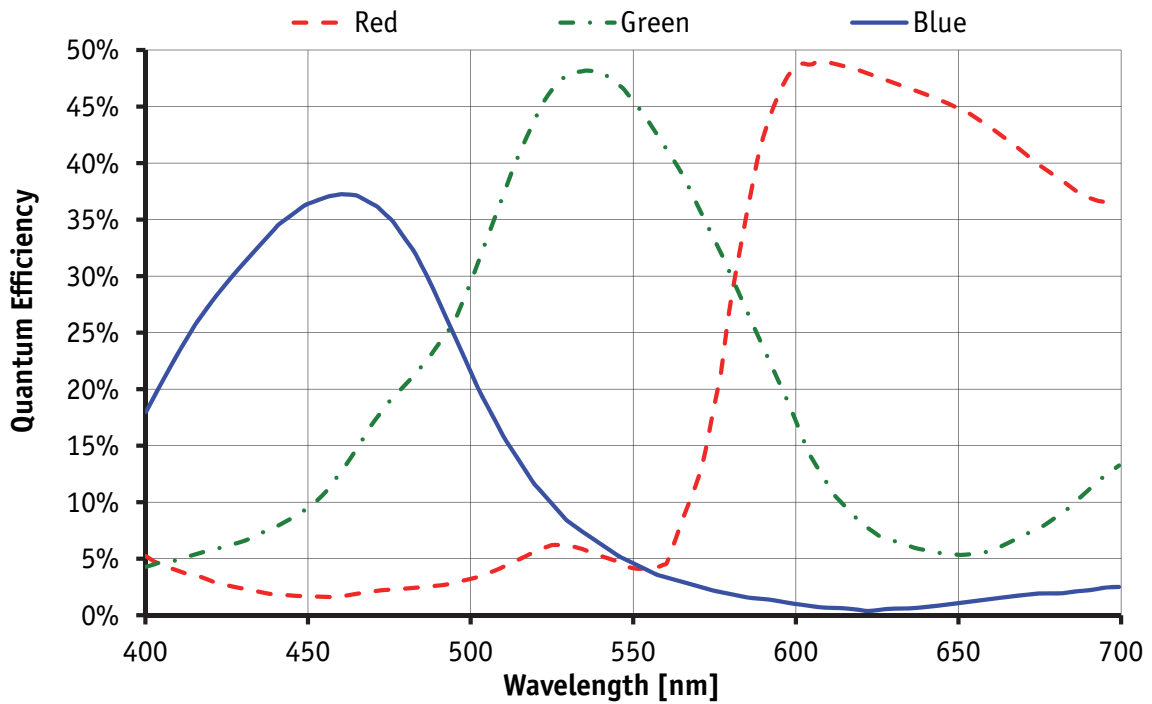

Figure 32: Spectral sensitivity of Manta G-282C (without IR cut filter)

Manta G-283B/C

Feature	Specification
Resolution	1936 x 1458
Sensor	SONY IT CCD ICX674ALG/AQG with EXview HAD II microlens
Type	CCD Progressive
Sensor size	Type 2/3
Cell size	4.54 μm
Lens mount	C-Mount
Max frame rate at full resolution	30 fps
Max image bit depth	12 bit
On-board FIFO	128 MByte, up to 47 frames at full resolution, Mono8/Bayer8, and a <i>GevSCPSPacketSize</i> = 8192 bytes per packet
Mono formats	Mono8, Mono12Packed, Mono12
Color formats	BayerRG8, BayerRG12Packed, BayerRG12, Mono8, RGB8Packed, YUV411Packed, YUV422Packed, YUV444Packed, BGR8Packed
Exposure control	41 μs to 38 s; 1 μs increments
Gain control	0–33 dB
Binning	Horizontal: 1 to 8 columns; Vertical: 1 to 14 rows
Decimation	Horizontal and Vertical: 1, 2, 4, 8 factor
Opto-coupled I/Os	2 input, 2 outputs
RS-232	1 TxD, 1 RxD
Voltage requirements	8–30 VDC, or PoE
Power consumption	3.7 W @ 12 VDC, 4.3 W PoE
Trigger latency*	Idle state: 7.2 μs Frame valid state: 18.4 μs
Trigger jitter*	Idle state: 4.0 μs Frame valid state: 15.2 μs
Operating temperature	+5 °C to +45 °C ambient temperature (without condensation)
Storage temperature	-10 °C to +70 °C ambient temperature (without condensation)
Body dimensions (L x W x H)	86.4 mm x 44 mm x 29 mm including connectors, w/o tripod and lens
Mass	150 g (without lens)
Hardware interface standard	PoE, IEEE 802.3af 1000BASE-T, 100BASE-TX
Software interface standard	GigE Vision Standard 1.2
Camera control interface	GenICam V1.0 compliant
Regulatory	CE, FCC Class B, RoHS (2011/65/EU)
*It is possible to start the exposure of the next frame while the previous frame is read out: <ul style="list-style-type: none"> – Idle state: sensor is ready and camera is idle, waiting for the next trigger – Frame valid state: sensor is reading out and camera is busy. If the next frame is requested by an external trigger in this state, higher latency may occur as compared to the Idle state 	

Table 16: Manta G-283B/C camera specifications

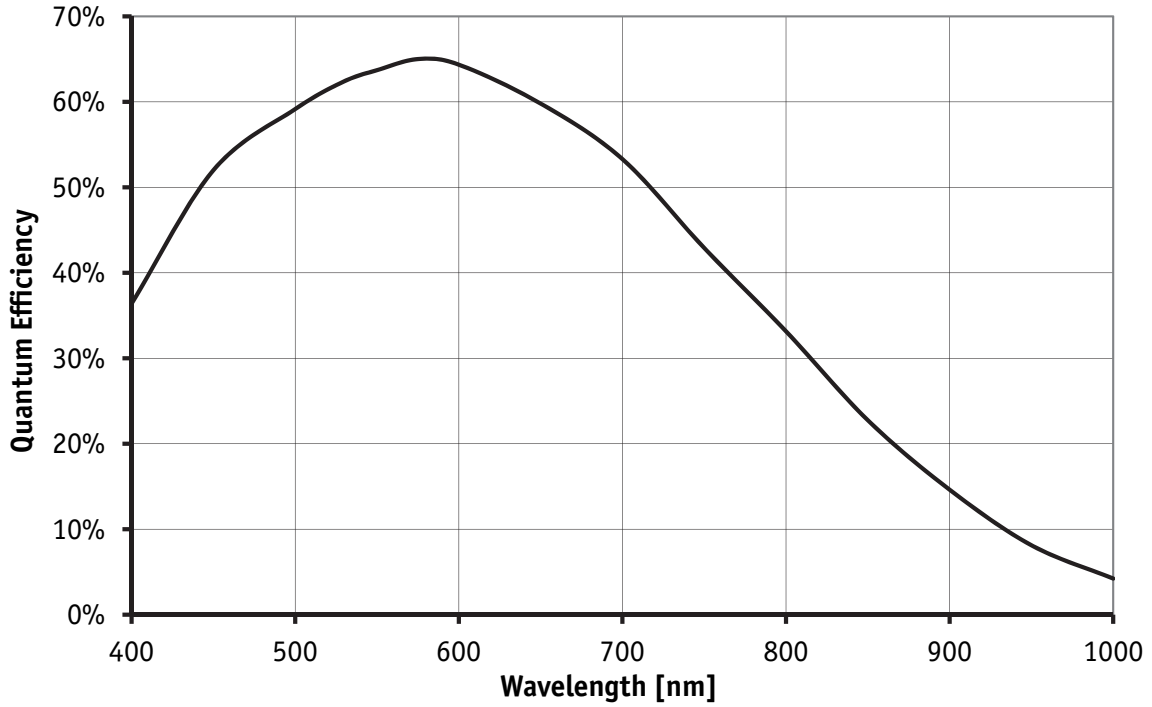

Figure 33: Spectral sensitivity of Manta G-283B (without protection/cover glass)

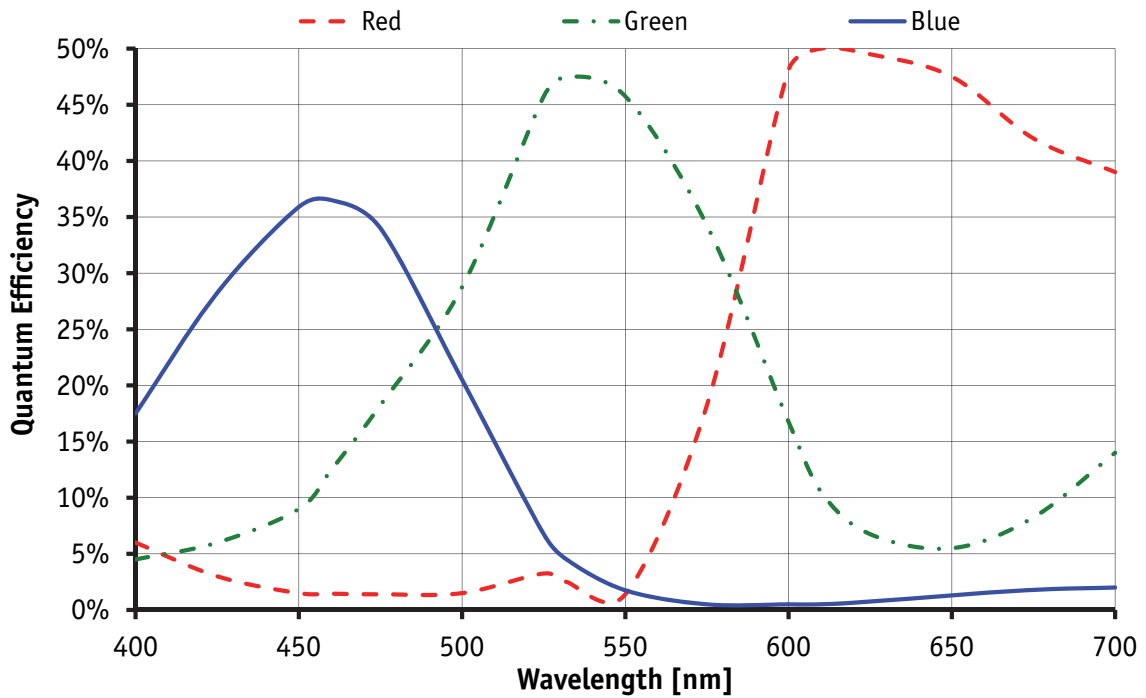

Figure 34: Spectral sensitivity of Manta G-283C (without IR cut filter)

Manta G-419B/C (NIR)

Feature	Specification
Resolution	2048 x 2048
Sensor	CMOSIS CMV4000 with microlenses and global shutter
Type	CMOS
Sensor size	Type 1
Cell size	5.5 μm
Lens mount	C-Mount
Max frame rate at full resolution	28 fps @ 124 MB/s; 32 fps burst mode*
Max image bit depth	12 bit
On-board FIFO	128 MByte, up to 31 frames at full resolution, Mono8/Bayer8, and a <i>GenSCSPacketSize</i> = 8192 bytes per packet
Mono formats	Mono8, Mono12Packed, Mono12
Color formats	BayerGB8, BayerGB12Packed, BayerGB12, Mono8, RGB8Packed, BGR8Packed, RGBA8Packed, BGRA8Packed, YUV411Packed, YUV422Packed, YUV444Packed
Exposure control	34 μs [†] to 126 s; 1 μs increments
Gain control	0–26 dB
Binning	N/A
Decimation	Horizontal and Vertical: 1, 2, 4, 8 factor
Opto-coupled I/Os	2 input, 2 outputs
RS-232	1 TxD, 1 RxD
Voltage requirements	8–30 VDC, or PoE
Power consumption	2.7 W @ 12 VDC, 3.1 W PoE
Operating temperature	+5 °C to +45 °C ambient temperature (without condensation)
Storage temperature	-10 °C to +70 °C ambient temperature (without condensation)
Body dimensions (L x W x H)	86.4 mm x 44 mm x 29 mm including connectors, w/o tripod and lens
Mass	150 g (without lens)
Hardware interface standard	PoE, IEEE 802.3af 1000BASE-T, 100BASE-TX
Software interface standard	GigE Vision Standard 1.2
Camera control interface	GenICam V1.0 compliant
Regulatory	CE, FCC Class B, RoHS (2011/65/EU)
*See <i>StreamFrameRateConstrain</i> in GigE Features Reference document.	
[†] Camera firmware v1.52.8151 shows minimum exposure values without frame overhead time, i.e., 1 μs . See sensor datasheet for details on frame overhead time. This will be fixed in the next firmware release.	

Table 17: Manta G-419B/C (NIR) camera specifications

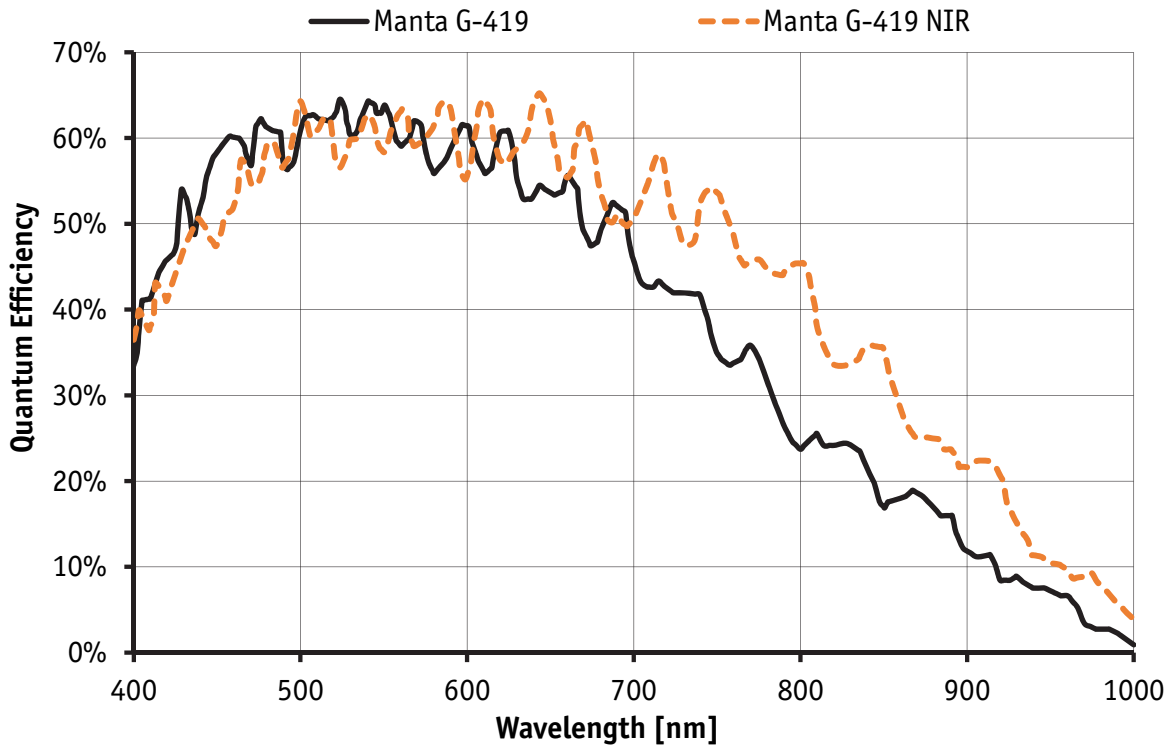

Figure 35: Spectral sensitivity of Manta G-419B

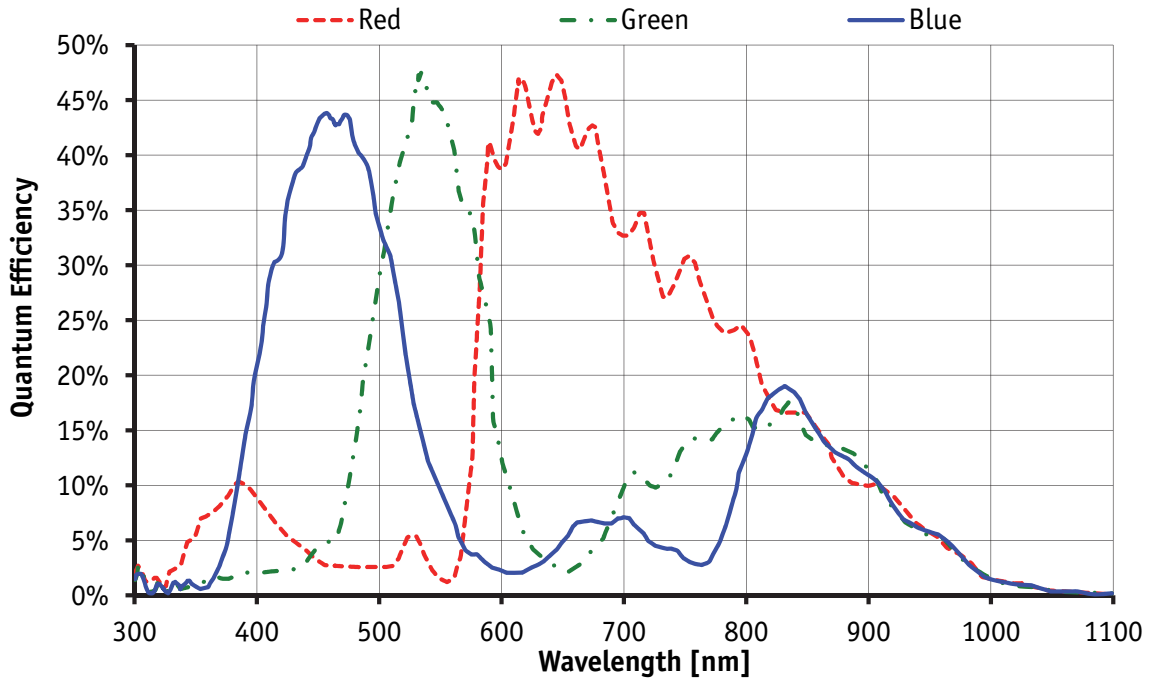

Figure 36: Spectral sensitivity of Manta G-419C (without IR cut filter)

Manta G-504B/C

Feature	Specification
Resolution	2452 x 2056
Sensor	SONY IT CCD ICX655AL/AQ with Super HAD microlens
Type	CCD Progressive
Sensor size	Type 2/3
Cell size	3.45 μm
Lens mount	C / CS-Mount
Max frame rate at full resolution	9 fps
Max image bit depth	12 bit
On-board FIFO	32 MByte, up to 6 frames at full resolution, Mono8/Bayer8, and a <i>GevSCPSPacketSize</i> = 8192 bytes per packet
Mono formats	Mono8, Mono12Packed, Mono12
Color formats	BayerGB8, BayerGB12Packed, BayerGB12, Mono8, RGB8Packed, YUV411Packed, YUV422Packed, YUV444Packed, BGR8Packed, RGBA8Packed, BGRA8Packed
Exposure control	38 μs to 60 s; 1 μs increments
Gain control	0–32 dB
Binning	Horizontal: 1 to 8 columns; Vertical: 1 to 14 rows
Decimation	Horizontal and Vertical: 1, 2, 4, 8 factor
Opto-coupled I/Os	2 input, 2 outputs
RS-232	1 TxD, 1 RxD
Voltage requirements	8–30 VDC, or PoE
Power consumption	3.9 W @ 12 VDC, 4.6 W PoE
Trigger latency*	Idle state: 12.8 μs Frame valid state: 34.0 μs
Trigger jitter*	Idle state: 9.1 μs Frame valid state: 30.3 μs
Operating temperature	+5 °C to +45 °C ambient temperature (without condensation)
Storage temperature	-10 °C to +70 °C ambient temperature (without condensation)
Body dimensions (L x W x H)	86.4 mm x 44 mm x 29 mm including connectors, w/o tripod and lens
Mass	200 g (without lens)
Hardware interface standard	PoE, IEEE 802.3af 1000BASE-T, 100BASE-TX
Software interface standard	GigE Vision Standard 1.2
Camera control interface	GenICam V1.0 compliant
Regulatory	CE, FCC Class B, RoHS (2011/65/EU)
*It is possible to start the exposure of the next frame while the previous frame is read out: <ul style="list-style-type: none"> – Idle state: sensor is ready and camera is idle, waiting for the next trigger – Frame valid state: sensor is reading out and camera is busy. If the next frame is requested by an external trigger in this state, higher latency may occur as compared to the Idle state 	

Table 18: Manta G-504B/C camera specifications

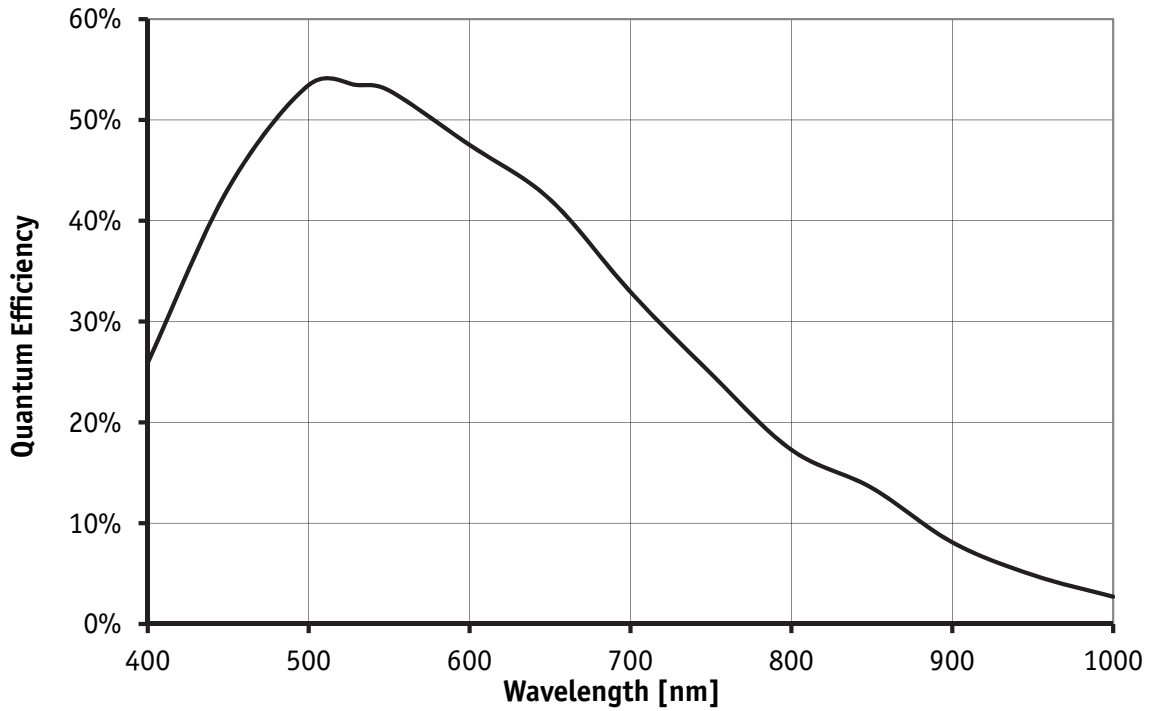

Figure 37: Spectral sensitivity of Manta G-504B (without protection/cover glass)

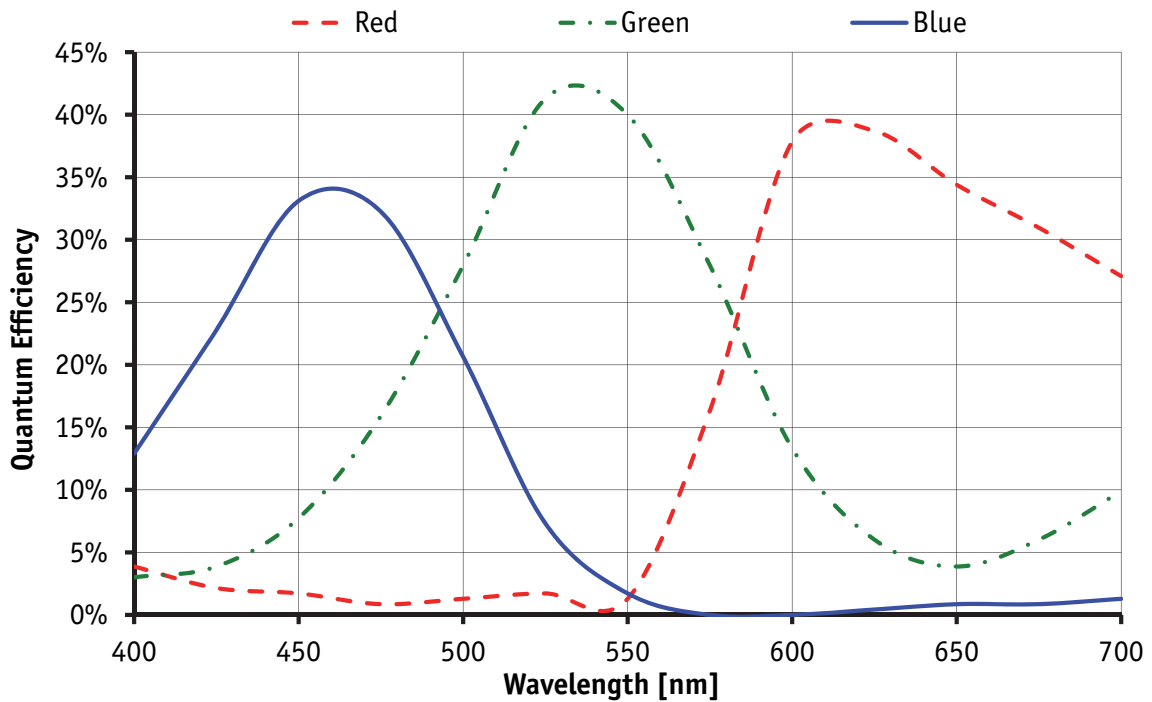

Figure 38: Spectral sensitivity of Manta G-504C (without IR cut filter)

Manta G-505B/C

Feature	Specification
Resolution	2452 x 2056
Sensor	SONY ICX625 with SuperHAD microlens
Type	CCD Progressive
Sensor size	Type 2/3
Cell size	3.45 μm
Lens mount	C / CS-Mount
Max frame rate at full resolution	15 fps
Max image bit depth	12 bit
On-board FIFO	128 MByte, up to 26 frames at full resolution, Mono8/Bayer8, and a <i>GevSCPSPacketSize</i> = 8192 bytes per packet
Mono formats	Mono8, Mono12Packed, Mono12
Color formats	BayerRG8, BayerRG12Packed, BayerRG12, Mono8, RGB8Packed, YUV411Packed, YUV422Packed, YUV444Packed, BGR8Packed
Exposure control	49 μs to 38 s; 1 μs increments
Gain control	0–31 dB
Binning	Horizontal: 1 to 8 columns; Vertical: 1 to 14 rows
Decimation	Horizontal and Vertical: 1, 2, 4, 8 factor
Opto-coupled I/Os	2 input, 2 outputs
RS-232	1 TxD, 1 RxD
Voltage requirements	8–30 VDC, or PoE
Power consumption	3.9 W @ 12 VDC, 4.5 W PoE
Trigger latency*	Idle state: 7.3 μs Frame valid state: 23.2 μs
Trigger jitter*	Idle state: 4.0 μs Frame valid state: 20.0 μs
Operating temperature	+5 °C to +45 °C ambient temperature (without condensation)
Storage temperature	-10 °C to +70 °C ambient temperature (without condensation)
Body dimensions (L x W x H)	86.4 mm x 44 mm x 29 mm including connectors, w/o tripod and lens
Mass	150 g (without lens)
Hardware interface standard	PoE, IEEE 802.3af 1000BASE-T, 100BASE-TX
Software interface standard	GigE Vision Standard 1.2
Camera control interface	GenICam V1.0 compliant
Regulatory	CE, FCC Class B, RoHS (2011/65/EU)
<p>*It is possible to start the exposure of the next frame while the previous frame is read out:</p> <ul style="list-style-type: none"> – Idle state: sensor is ready and camera is idle, waiting for the next trigger – Frame valid state: sensor is reading out and camera is busy. If the next frame is requested by an external trigger in this state, higher latency may occur as compared to the Idle state 	

Table 19: Manta G-505B/C camera specifications

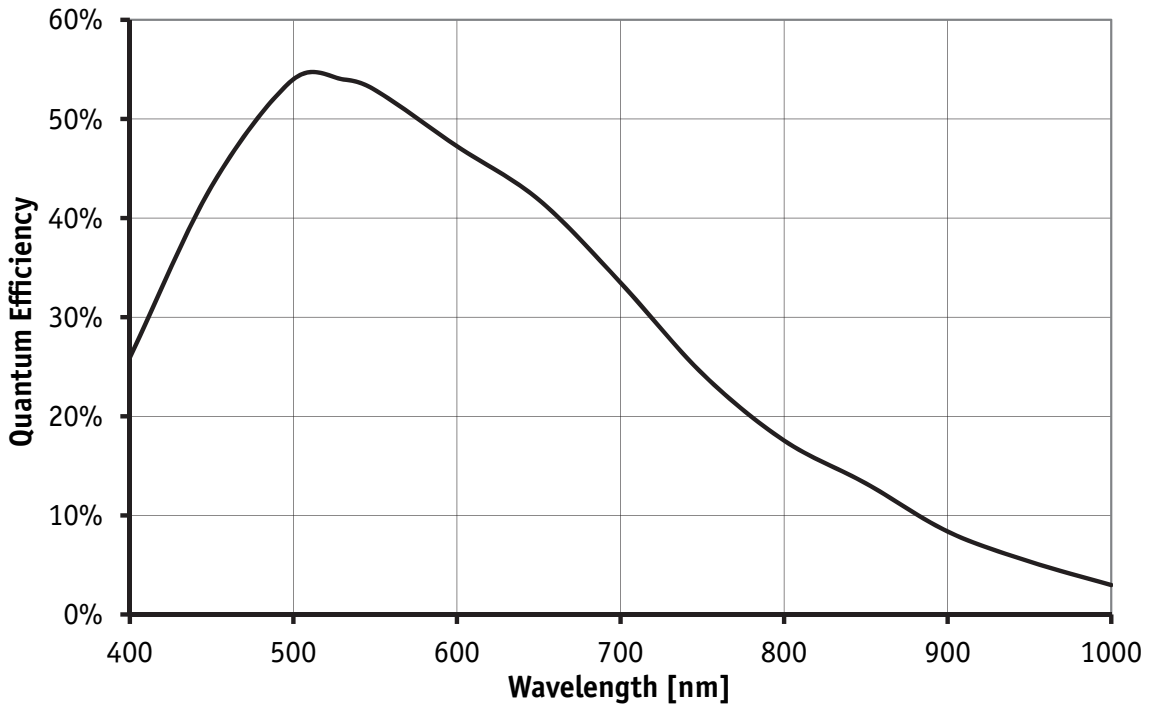

Figure 39: Spectral sensitivity of Manta G-505B (without protection/cover glass)

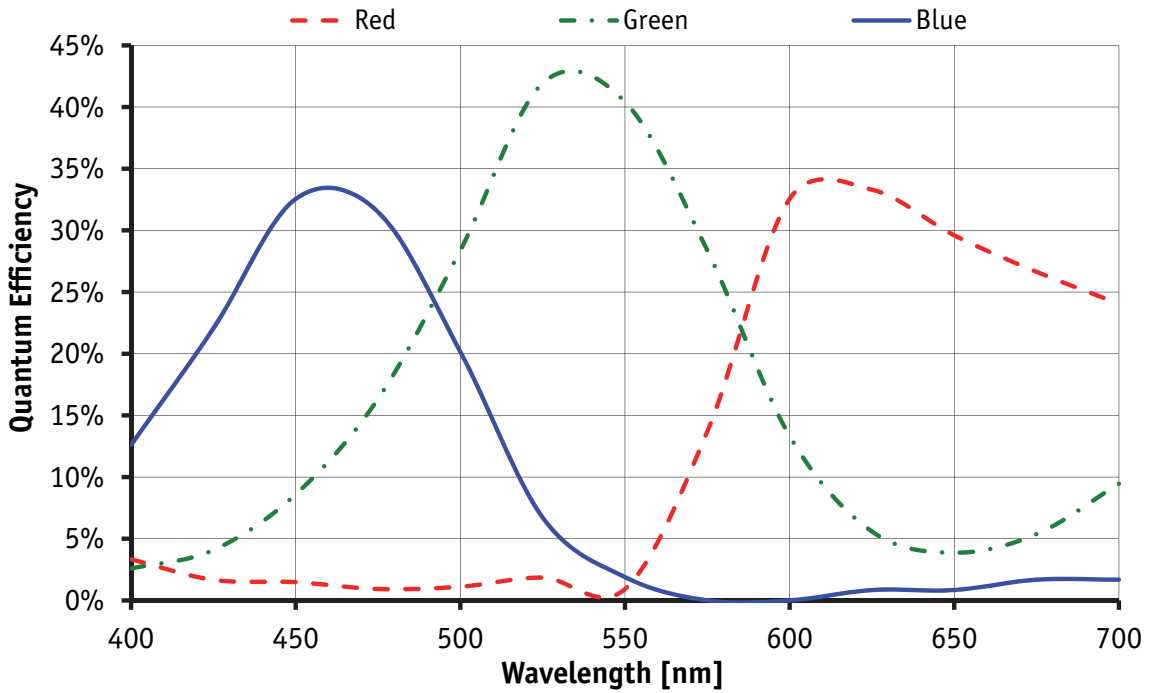

Figure 40: Spectral sensitivity of Manta G-505C (without IR cut filter)

Manta G-609B/C

Feature	Specification
Resolution	2752 x 2206
Sensor	SONY IT CCD ICX694ALG/AQG with EXview HAD II microlens
Type	CCD Progressive
Sensor size	Type 1
Cell size	4.54 μm
Lens mount	C-Mount
Max frame rate at full resolution	15 fps
Max image bit depth	12 bit
On-board FIFO	128 MByte, up to 21 frames at full resolution, Mono8/Bayer8, and a <i>GevSCPSPacketSize</i> = 8192 bytes per packet
Mono formats	Mono8, Mono12Packed, Mono12
Color formats	BayerRG8, BayerRG12Packed, BayerRG12, Mono8, RGB8Packed, YUV411Packed, YUV422Packed, YUV444Packed, BGR8Packed
Exposure control	41 μs to 38 s; 1 μs increments
Gain control	0–33 dB
Binning	Horizontal: 1 to 8 columns; Vertical: 1 to 14 rows
Decimation	Horizontal and Vertical: 1, 2, 4, 8 factor
Opto-coupled I/Os	2 input, 2 outputs
RS-232	1 TxD, 1 RxD
Voltage requirements	8–30 VDC, or PoE
Power consumption	3.9 W @ 12 VDC, 4.6 W PoE
Trigger latency*	Idle state: 7.2 μs Frame valid state: 22.0 μs
Trigger jitter*	Idle state: 4.0 μs Frame valid state: 18.8 μs
Operating temperature	+5 °C to +45 °C ambient temperature (without condensation)
Storage temperature	-10 °C to +70 °C ambient temperature (without condensation)
Body dimensions (L x W x H)	86.4 mm x 44 mm x 29 mm including connectors, w/o tripod and lens
Mass	150 g (without lens)
Hardware interface standard	PoE, IEEE 802.3af 1000BASE-T, 100BASE-TX
Software interface standard	GigE Vision Standard 1.2
Camera control interface	GenICam V1.0 compliant
Regulatory	CE, FCC Class B, RoHS (2011/65/EU)
<p>*It is possible to start the exposure of the next frame while the previous frame is read out:</p> <ul style="list-style-type: none"> – Idle state: sensor is ready and camera is idle, waiting for the next trigger – Frame valid state: sensor is reading out and camera is busy. If the next frame is requested by an external trigger in this state, higher latency may occur as compared to the Idle state 	

Table 20: Manta G-609B/C camera specifications

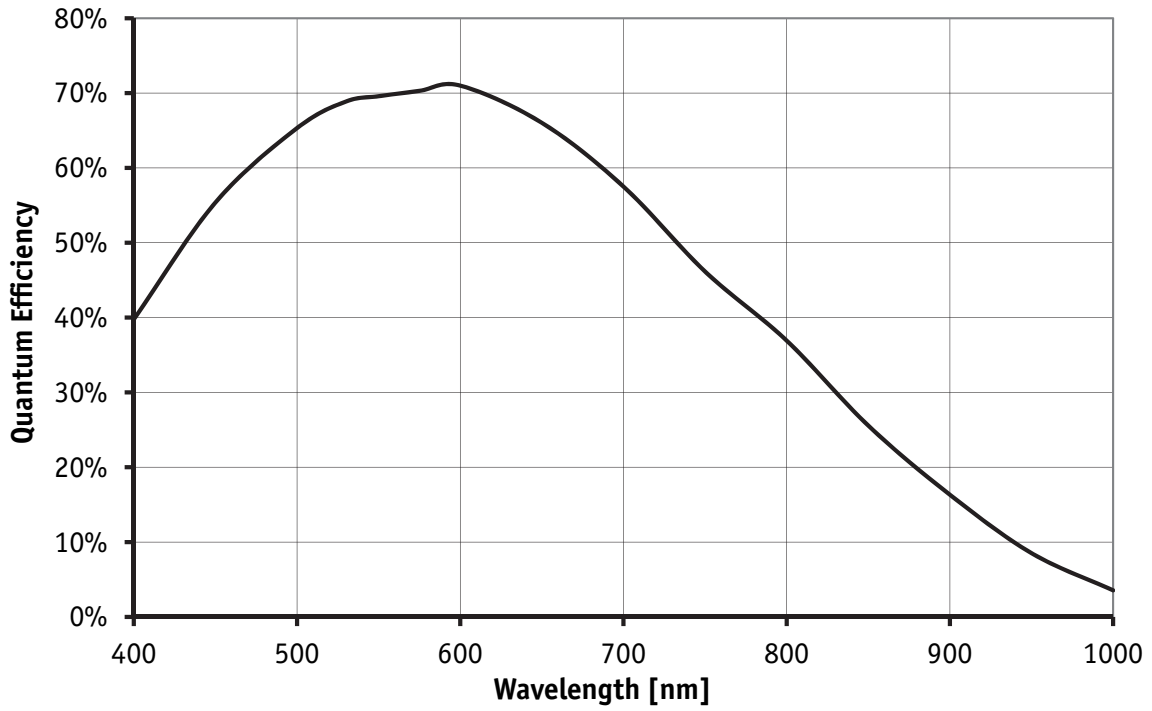

Figure 41: Spectral sensitivity of Manta G-609B (without protection/cover glass)

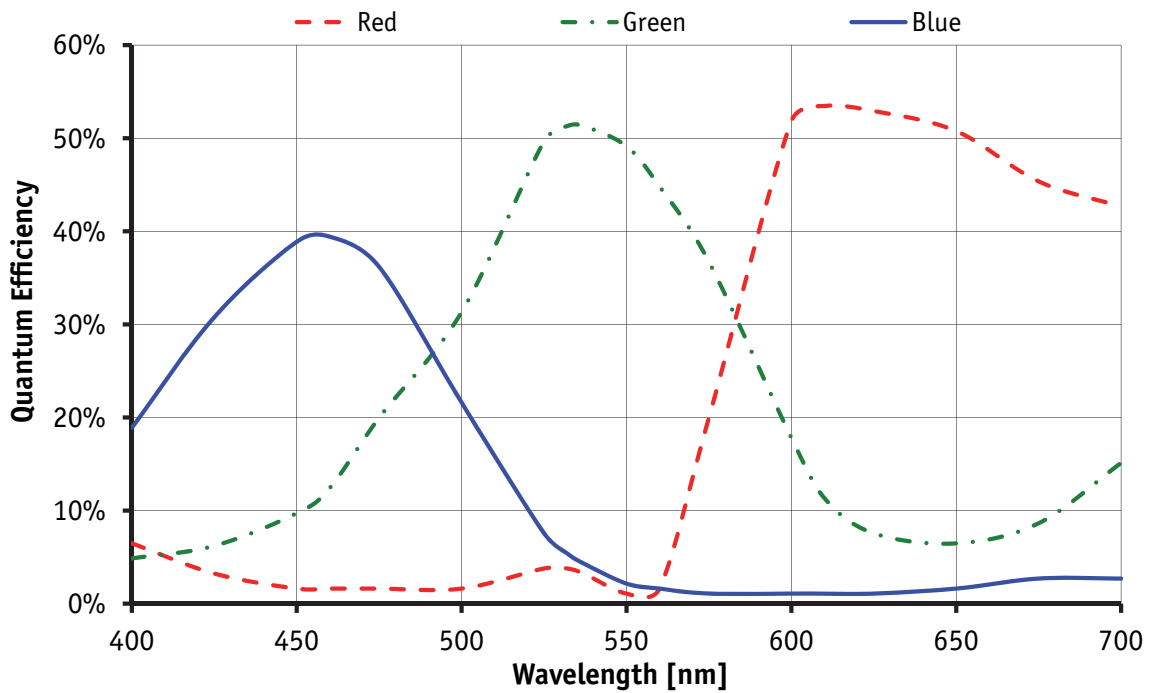

Figure 42: Spectral sensitivity of Manta G-609C (without IR cut filter)

Manta G-917B/C

Feature	Specification
Resolution	3384 x 2710
Sensor	SONY IT CCD ICX814 ALG/AQG with EXview HAD II microlens
Type	CCD Progressive
Sensor size	Type 1
Cell size	3.69 μm
Lens mount	C-Mount
Max frame rate at full resolution	10 fps
Max image bit depth	12 bit
On-board FIFO	128 MByte, up to 14 frames at full resolution, Mono8/Bayer8, and a <i>GenSCSPacketSize</i> = 8192 bytes per packet
Mono formats	Mono8, Mono12Packed, Mono12
Color formats	BayerRG8, BayerRG12Packed, BayerRG12, Mono8, RGB8Packed, YUV411Packed, YUV422Packed, YUV444Packed, BGR8Packed
Exposure control	42 μs to 38 s; 1 μs increments
Gain control	0–32 dB
Binning	Horizontal: 1 to 8 columns; Vertical: 1 to 14 rows
Decimation	Horizontal and Vertical: 1, 2, 4, 8 factor
Opto-coupled I/Os	2 input, 2 outputs
RS-232	1 TxD, 1 RxD
Voltage requirements	8–30 VDC, or PoE
Power consumption	4.0 W @ 12 VDC, 4.7 W PoE
Trigger latency*	Idle state: 7.0 μs Frame valid state: 25.1 μs
Trigger jitter*	Idle state: 4.0 μs Frame valid state: 22.1 μs
Operating temperature	+5 °C to +45 °C ambient temperature (without condensation)
Storage temperature	-10 °C to +70 °C ambient temperature (without condensation)
Body dimensions (L x W x H)	86.4 mm x 44 mm x 29 mm including connectors, w/o tripod and lens
Mass	150 g (without lens)
Hardware interface standard	PoE, IEEE 802.3af 1000BASE-T, 100BASE-TX
Software interface standard	GigE Vision Standard 1.2
Camera control interface	GenICam V1.0 compliant
Regulatory	CE, FCC Class B, RoHS (2011/65/EU)
*It is possible to start the exposure of the next frame while the previous frame is read out: <ul style="list-style-type: none"> – Idle state: sensor is ready and camera is idle, waiting for the next trigger – Frame valid state: sensor is reading out and camera is busy. If the next frame is requested by an external trigger in this state, higher latency may occur as compared to the Idle state 	

Table 21: Manta G-917B/C camera specifications

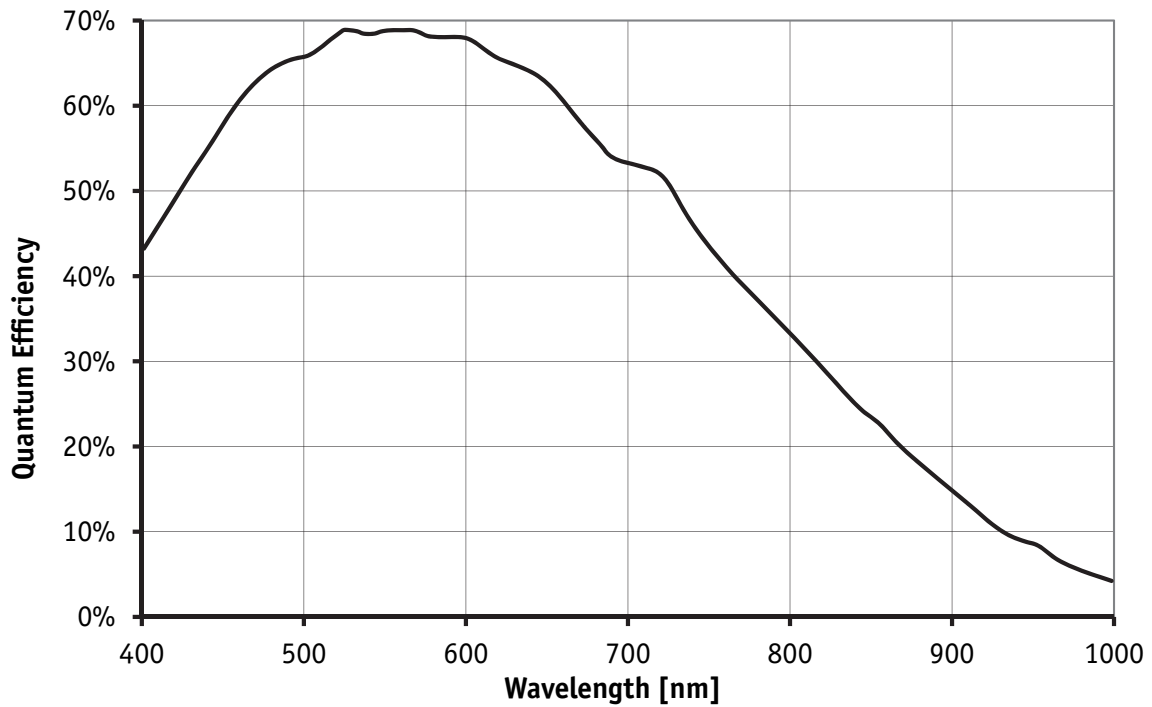

Figure 43: Spectral sensitivity of Manta G-917B (without protection/cover glass)

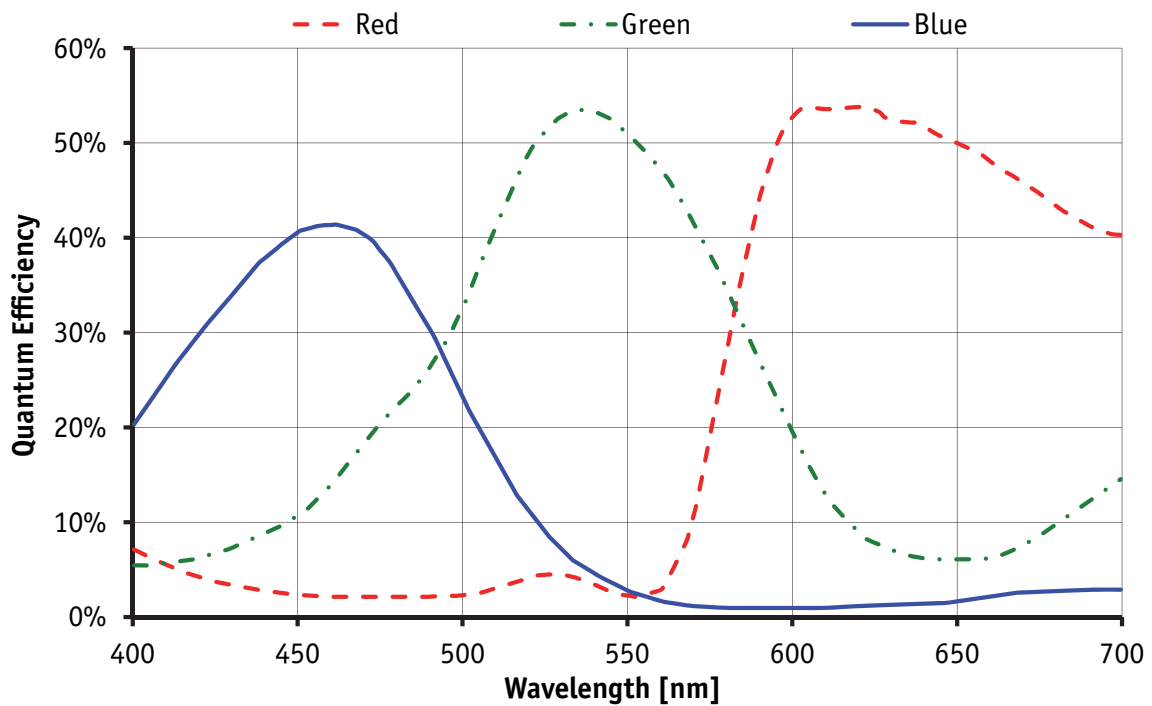

Figure 44: Spectral sensitivity of Manta G-917C (without IR cut filter)

Camera smart features

Allied Vision cameras support a number of standard and extended features. The table below identifies a selection of interesting capabilities of the Manta camera family.

www

A complete listing of camera controls, including control definitions can be found online:



PvAPI users: [GigE Camera and Driver Attributes](#) document

VIMBA and third-party users: [GigE Features Reference](#) document

Control	Description
Gain control	Manual and auto
Exposure control	Manual and auto
White balance	Red and blue channel; manual and auto control
External trigger event	Rising edge, falling edge, any edge, level high, level low
Imaging modes	Free-running, external trigger, fixed rate, software trigger
Sync out modes	Trigger ready, trigger input, exposing, readout, imaging, strobe, GPO
Region of interest	Independent x and y control with 1 pixel resolution
Multicast	Streaming to multiple hosts
Event channel	In-camera events including exposure start and trigger are asynchronously broadcasted to the host computer
Chunk data	Captured images are bundled with attribute information such as exposure and gain value
Color correction matrix	Correct color rendering for specific color temperature
Gamma, Hue, Saturation	Adjust image gamma, hue and saturation
Lens control	Video-type auto-iris
Look-up table (LUT)	LUTs available on select models
Temperature monitoring	Monitor camera temperature: resolution 0.031, accuracy ± 1 °C. Available only for Manta type B cameras.

Table 22: Manta camera smart features

Filter and lenses

- **Monochrome** cameras are equipped with **protection glass**.
- **Color** cameras are equipped with **IR cut filter**.

IR cut filter: spectral transmission

The following illustration shows the spectral transmission of the IR cut filter:

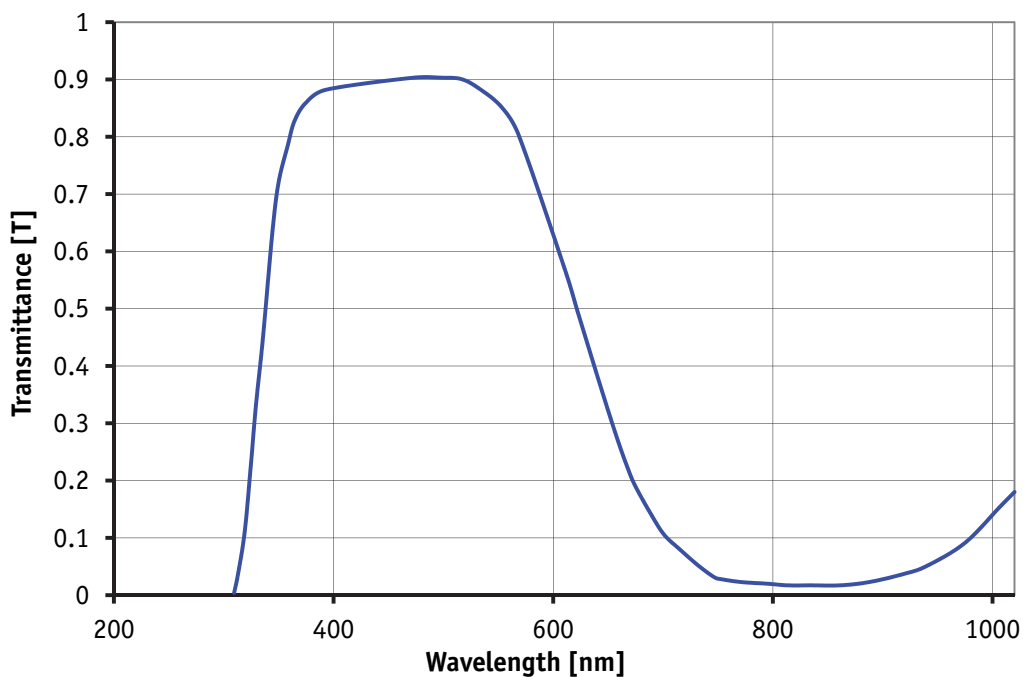

Figure 45: Approximate spectral transmission of IR cut filter (may vary slightly by filter lot) (type Hoya C5000)

Camera lenses

Allied Vision offers different lenses from a variety of manufacturers.

www



Accessories:

Please contact Allied Vision sales representative or your local Allied Vision dealer for information on accessories offered by Allied Vision:

<http://www.alliedvision.com/en/about-us/where-we-are.html>

The following tables list selected image formats in **width x height** depending on camera type, distance and the focal length of the lens.

Note

Lenses with focal lengths < 8 mm may show shading in the edges of the image due to microlenses on the sensor's pixel.

Ask your dealer if you require non C-Mount lenses.

Focal length for type 1/4 sensors: Manta G-031	Distance = 500 mm	Distance = 1000 mm
2.8 mm	655 mm x 490 mm	1314 mm x 983 mm
4 mm	458 mm x 342 mm	919 mm x 687 mm
6 mm	304 mm x 227 mm	611 mm x 457 mm
8 mm	227 mm x 170 mm	458 mm x 342 mm
12 mm	150 mm x 112 mm	304 mm x 227 mm
16 mm	112 mm x 83 mm	227 mm x 170 mm
25 mm	70 mm x 52 mm	114 mm x 108 mm

Table 23: Focal length vs. field of view (Manta G-031)

Focal length for type 1/3 sensor: Manta G-032	Distance = 500 mm	Distance = 1000 mm
4.0 mm	608 mm x 446 mm	1220 mm x 896 mm
4.8 mm	506 mm x 371 mm	1016 mm x 746 mm
8 mm	301 mm x 221 mm	608 mm x 446 mm
12 mm	199 mm x 146 mm	403 mm x 296 mm
16 mm	148 mm x 109 mm	301 mm x 221 mm
25 mm	93 mm x 68 mm	191 mm x 140 mm
35 mm	65 mm x 48 mm	135 mm x 99 mm

Table 24: Focal length vs. field of view (Manta G-032)

Focal length for type 1/3 sensors: Manta G-095/125	Distance = 500 mm	Distance = 1000 mm
4.0 mm	595 mm x 446 mm	1195 mm x 896 mm
4.8 mm	495 mm x 371 mm	995 mm x 746 mm
8 mm	295 mm x 221 mm	595 mm x 446 mm
12 mm	195 mm x 146 mm	395 mm x 296 mm
16 mm	145 mm x 109 mm	295 mm x 221 mm
25 mm	91 mm x 68 mm	187 mm x 140 mm
35 mm	64 mm x 48 mm	132 mm x 99 mm

Table 25: Focal length vs. field of view (Manta G-095/125)

Focal length for type 1/2 sensors: Manta G-033/046/146		
	Distance = 500 mm	Distance = 1000 mm
4.8 mm	660 mm x 495 mm	1327 mm x 995 mm
8 mm	394 mm x 295 mm	794 mm x 595 mm
12 mm	260 mm x 195 mm	527 mm x 395 mm
16 mm	194 mm x 145 mm	394 mm x 295 mm
25 mm	122 mm x 91 mm	250 mm x 187 mm
35 mm	85 mm x 64 mm	176 mm x 132 mm
50 mm	58 mm x 43 mm	122 mm x 91 mm

Table 26: Focal length vs. field of view (Manta G-033/046/146)

Focal length for type 1/1.8 sensors: Manta G-201		
	Distance = 500 mm	Distance = 1000 mm
4.8 mm	740 mm x 549 mm	1488 mm x 1103 mm
8 mm	441 mm x 327 mm	890 mm x 660 mm
12 mm	292 mm x 216 mm	591 mm x 438 mm
16 mm	217 mm x 161 mm	441 mm x 327 mm
25 mm	136 mm x 101 mm	280 mm x 207 mm
35 mm	95 mm x 71 mm	198 mm x 147 mm
50 mm	65 mm x 48 mm	136 mm x 101 mm

Table 27: Focal length vs. field of view (Manta G-201)

Focal length for type 1/1.8 sensors: Manta G-282		
	Distance = 500 mm	Distance = 1000 mm
4.8 mm	737 mm x 555 mm	1480 mm x 1115 mm
6 mm	588 mm x 443 mm	1183 mm x 891 mm
6.5 mm	542 mm x 408 mm	1091 mm x 822 mm
8 mm	439 mm x 331 mm	885 mm x 667 mm
10 mm	350 mm x 264 mm	707 mm x 533 mm
12 mm	290 mm x 219 mm	588 mm x 443 mm
16 mm	216 mm x 163 mm	439 mm x 331 mm
25 mm	136 mm x 102 mm	278 mm x 210 mm
35 mm	95 mm x 71 mm	197 mm x 148 mm
50 mm	64 mm x 48 mm	136 mm x 102 mm
75 mm	40 mm x 30 mm	88 mm x 66 mm
90 mm	33 mm x 25 mm	72 mm x 54 mm

Table 28: Focal length vs. field of view (Manta G-282)

Focal length for type 1/1.2 sensors: Manta G-235		
	Distance = 500 mm	Distance = 1000 mm
8 mm	698 mm x 181 mm	1407 mm x 364 mm
10 mm	556 mm x 144 mm	1123 mm x 291 mm
12 mm	461 mm x 119 mm	934 mm x 242 mm
16 mm	343 mm x 89 mm	698 mm x 181 mm
25 mm	216 mm x 56 mm	442 mm x 115 mm
35 mm	151 mm x 39 mm	313 mm x 81 mm
50 mm	102 mm x 26 mm	216 mm x 56 mm

Table 29: Focal length vs. field of view (Manta G-235)

Focal length for type 2/3 sensors: Manta G-145/504	Distance = 500 mm	Distance = 1000 mm
4.8 mm	908 mm x 681 mm	1825 mm x 1368 mm
8 mm	541 mm x 406 mm	1091 mm x 818 mm
12 mm	358 mm x 268 mm	725 mm x 543 mm
16 mm	266 mm x 200 mm	541 mm x 406 mm
25 mm	167 mm x 125 mm	343 mm x 257 mm
35 mm	117 mm x 88 mm	243 mm x 182 mm
50 mm	79 mm x 59 mm	167 mm x 125 mm

Table 30: Focal length vs. field of view (Manta G-145/504)

Focal length for type 2/3 sensor: Manta G-283	Distance = 500 mm	Distance = 1000 mm
4.8 mm	907 mm x 683 mm	1822 mm x 1373 mm
6 mm	724 mm x 545 mm	1456 mm x 1097 mm
6.5 mm	667 mm x 503 mm	1344 mm x 1012 mm
8 mm	541 mm x 407 mm	1090 mm x 821 mm
10 mm	431 mm x 324 mm	870 mm x 655 mm
12 mm	357 mm x 269 mm	724 mm x 545 mm
16 mm	266 mm x 200 mm	541 mm x 407 mm
25 mm	167 mm x 126 mm	343 mm x 258 mm
35 mm	117 mm x 88 mm	242 mm x 183 mm
50 mm	79 mm x 60 mm	167 mm x 126 mm
75 mm	50 mm x 38 mm	108 mm x 82 mm
90 mm	40 mm x 30 mm	89 mm x 67 mm

Table 31: Focal length vs. field of view (Manta G-283)

Focal length for type 2/3* sensor: Manta G-223	Distance = 500 mm	Distance = 1000 mm
4.8 mm	1162 mm x 617 mm	2335 mm x 1240 mm
6 mm	927 mm x 492 mm	1865 mm x 991 mm
6.5 mm	855 mm x 454 mm	1721 mm x 914 mm
8 mm	692 mm x 368 mm	1396 mm x 742 mm
10 mm	552 mm x 293 mm	1114 mm x 597 mm
12 mm	458 mm x 243 mm	927 mm x 492 mm
16 mm	341 mm x 181 mm	692 mm x 369 mm
25 mm	214 mm x 114 mm	439 mm x 223 mm
35 mm	150 mm x 79 mm	310 mm x 165 mm
50 mm	101 mm x 54 mm	214 mm x 114 mm
75 mm	64 mm x 34 mm	139 mm x 74 mm
90 mm	51 mm x 27 mm	114 mm x 60 mm

Table 32: Focal length vs. field of view (Manta G-223)

* A 2/3 inch lens may cause vignetting (1 inch lens recommended)

Focal length for type 2/3 sensor: Manta G-505	Distance = 500 mm	Distance = 1000 mm
6 mm	700 mm x 585 mm	1408 mm x 1176 mm
8 mm	523 mm x 437 mm	1054 mm x 880 mm
12 mm	346 mm x 289 mm	700 mm x 585 mm
16 mm	257 mm x 215 mm	523 mm x 437 mm
25 mm	162 mm x 135 mm	332 mm x 277 mm
35 mm	113 mm x 94 mm	234 mm x 196 mm
50 mm	77 mm x 64 mm	162 mm x 135 mm

Table 33: Focal length vs. field of view (Manta G-505)

Focal length for type 1 sensor for Manta G-419	Distance = 500 mm	Distance = 1000 mm
8 mm	692 mm x 692mm	1396 mm x 1396 mm
10 mm	552 mm x 552 mm	1114 mm x 1114 mm
12 mm	458 mm x 458 mm	928 mm x 928 mm
16 mm	340 mm x 340 mm	692 mm x 692 mm
25 mm	214 mm x 214 mm	439 mm x 439 mm
35 mm	150 mm x 150 mm	310 mm x 310 mm
50 mm	101 mm x 101 mm	214 mm x 214 mm
75 mm	64 mm x 64 mm	139 mm x 139 mm
90 mm	51 mm x 51 mm	104 mm x 104 mm

Table 34: Focal length vs. field of view (Manta G-419)

Focal length for type 1 sensors for Manta G-609/917	Distance = 500 mm	Distance = 1000 mm
8 mm	768 mm x 616 mm	1549 mm x 1242 mm
10 mm	612 mm x 491 mm	1237 mm x 992 mm
12 mm	508 mm x 407 mm	1028 mm x 825 mm
16 mm	378 mm x 303 mm	768 mm x 616 mm
25 mm	237 mm x 190 mm	487 mm x 391 mm
35 mm	166 mm x 133 mm	344 mm x 276 mm
50 mm	112 mm x 90 mm	237 mm x 190 mm
75 mm	71 mm x 57 mm	154 mm x 124 mm
90 mm	57 mm x 46 mm	126 mm x 101 mm

Table 35: Focal length vs. field of view (Manta G-609/917)

Camera dimensions (type A)

Note Manta type A cameras have different housings than Manta type B cameras.



Manta type A cameras: G-031 / 032 / 033 / 046 / 095 / 125 / 145 / 146 / 201 / 504

Manta type B cameras: G-223 / 235 / 282 / 283 / 419 / 505 / 609 / 917, see [Camera dimensions \(type B\)](#) on page 87.

Note For information on **camera dimensions for non-PoE Manta cameras up to serial number 503323258:**



See [Exceptions for non-PoE Manta cameras up to serial number 503323258](#) on page 153.

Note For information on sensor position accuracy:



See [Sensor position accuracy of Manta cameras](#) on page 152.

Tripod adapter

This tripod adapter (Allied Vision order number 5153) can be used for Manta cameras (type A and type B) and is only designed for standard housings.

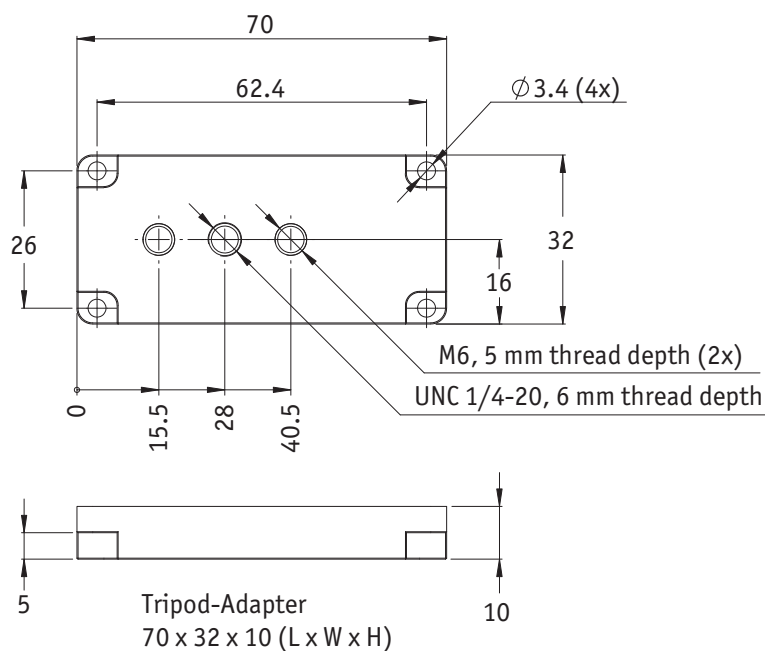

Figure 46: Tripod dimensions

Manta standard housing (type A)

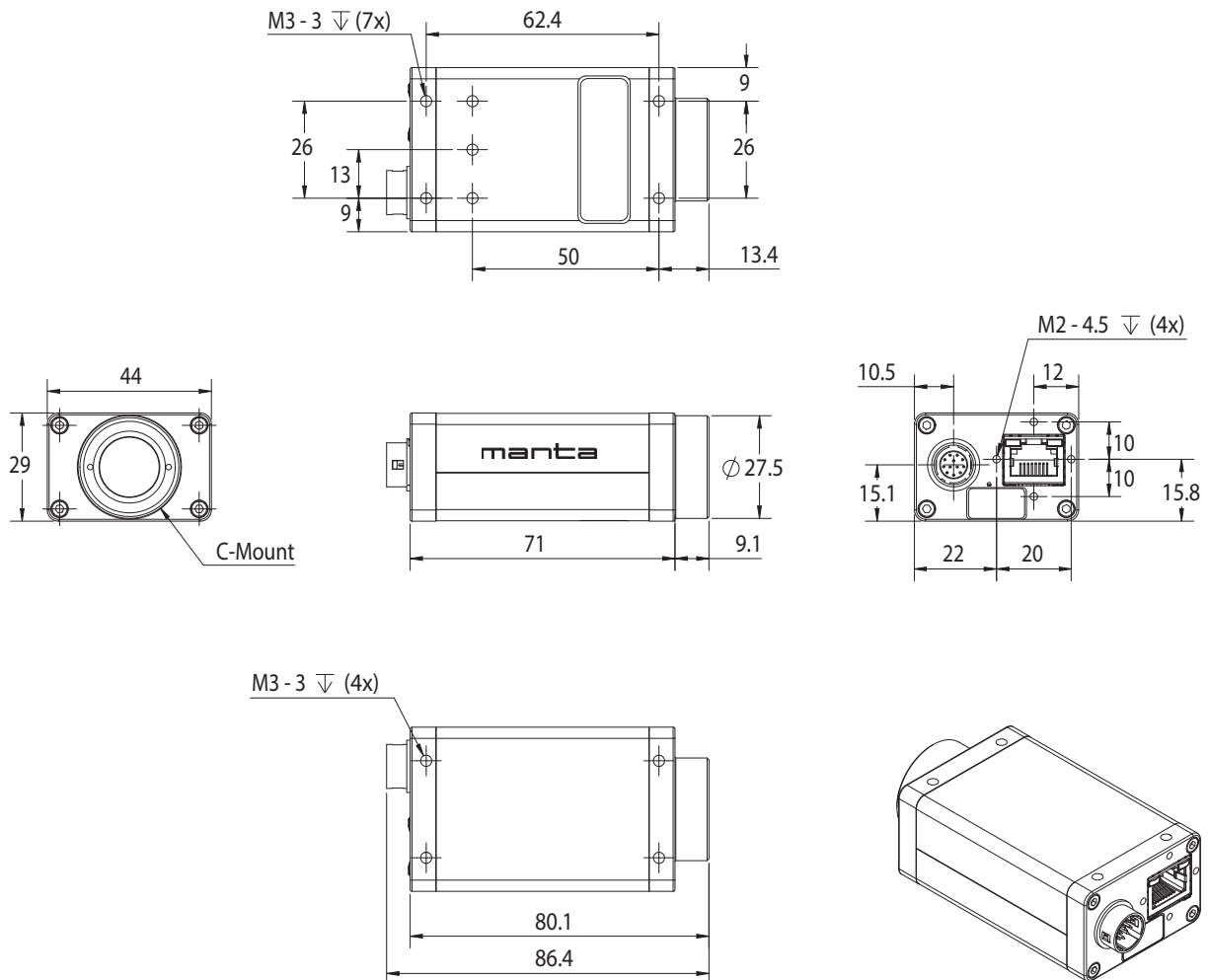

Figure 47: Camera dimensions standard housing type A
G-031 / 032 / 033 / 046 / 095 / 125 / 145 / 146 / 201 / 504

Manta standard angled-head housings (type A)

Manta W90

This version has the sensor tilted by 90 degrees clockwise, so that it views upwards.

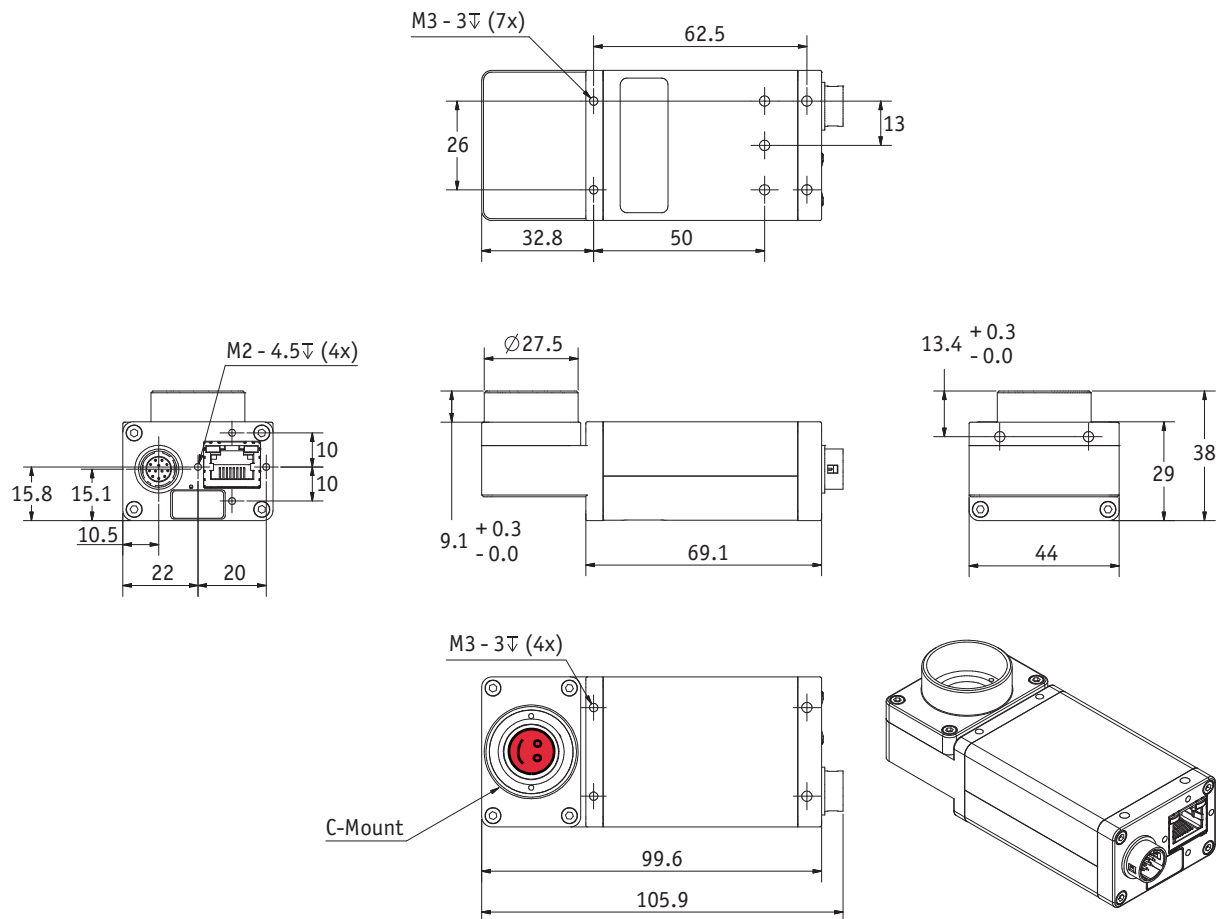

Figure 48: Dimensions for Manta type A W90 cameras: Manta G-031 / 032 / 033 / 046 / 095 / 125 / 145 / 146 / 201 / 504

Manta W90 S90

This version has the sensor tilted by 90 degrees clockwise, so that it views upwards.

The sensor is also rotated by 90 degrees clockwise.

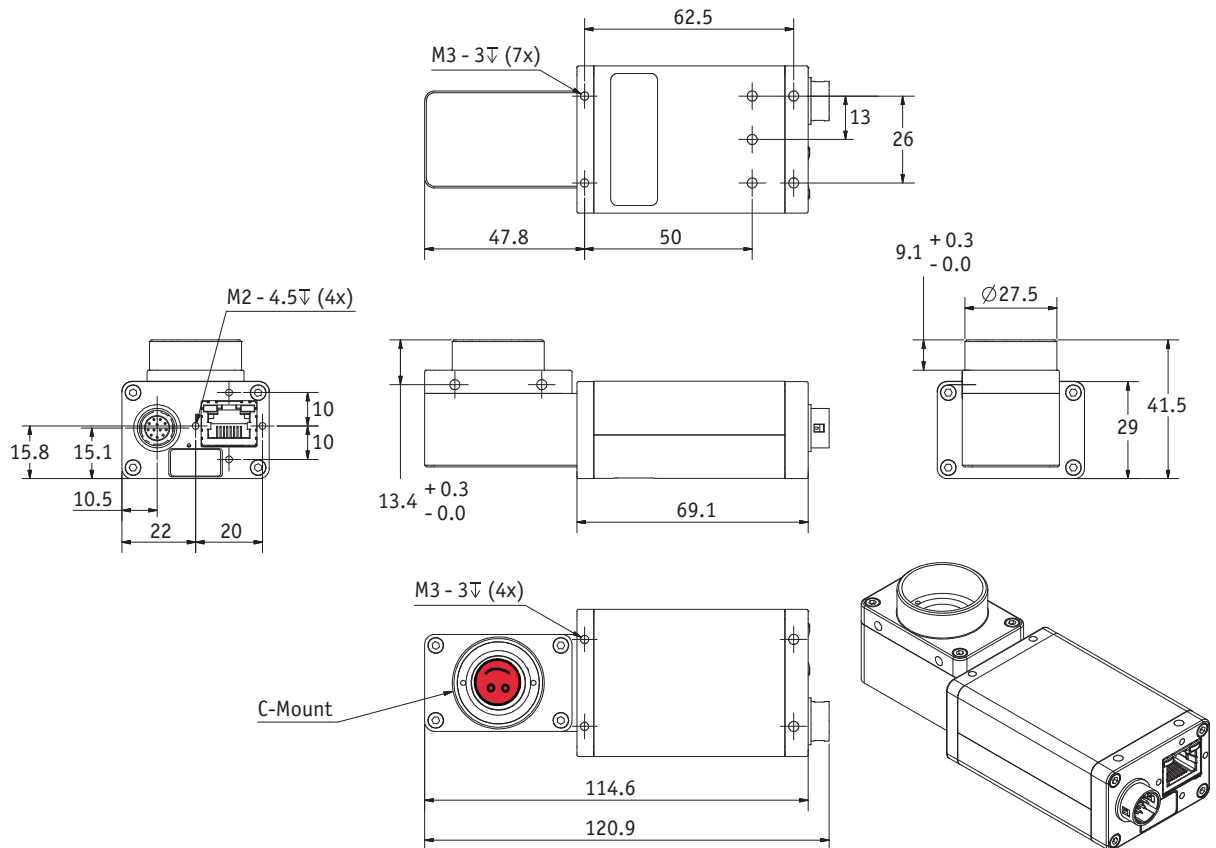

Figure 49: Dimensions for Manta type A W90 S90 cameras: Manta G-031 / 032 / 033 / 046 / 095 / 125 / 145 / 146 / 201 / 504

Manta W270

This version has the sensor tilted by 270 degrees clockwise, so that it views downwards.

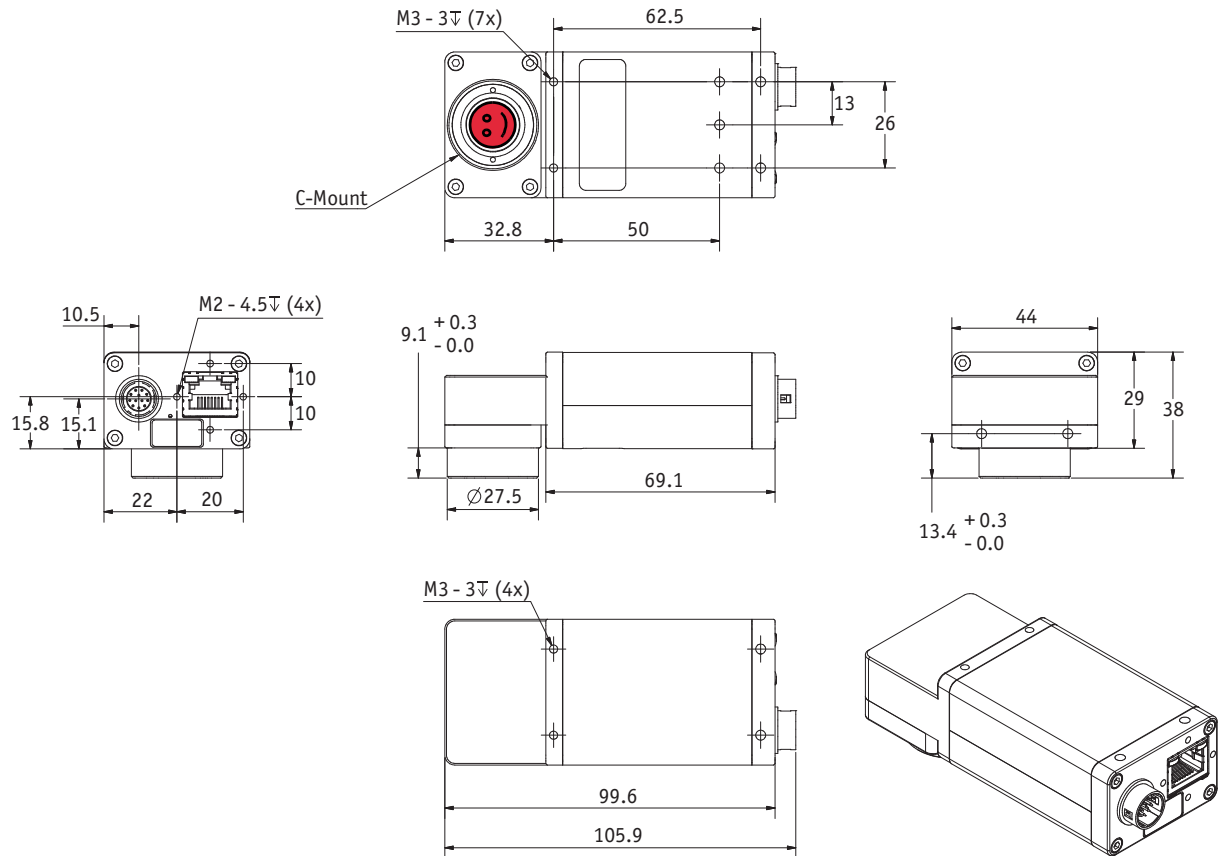

Figure 50: Dimensions for Manta type A W270 cameras: Manta G-031 / 032 / 033 / 046 / 095 / 125 / 145 / 146 / 201 / 504

Manta W270 S90

This version has the sensor tilted by 270 degrees clockwise, so that it views downwards.

The sensor is also rotated by 90 degrees clockwise.

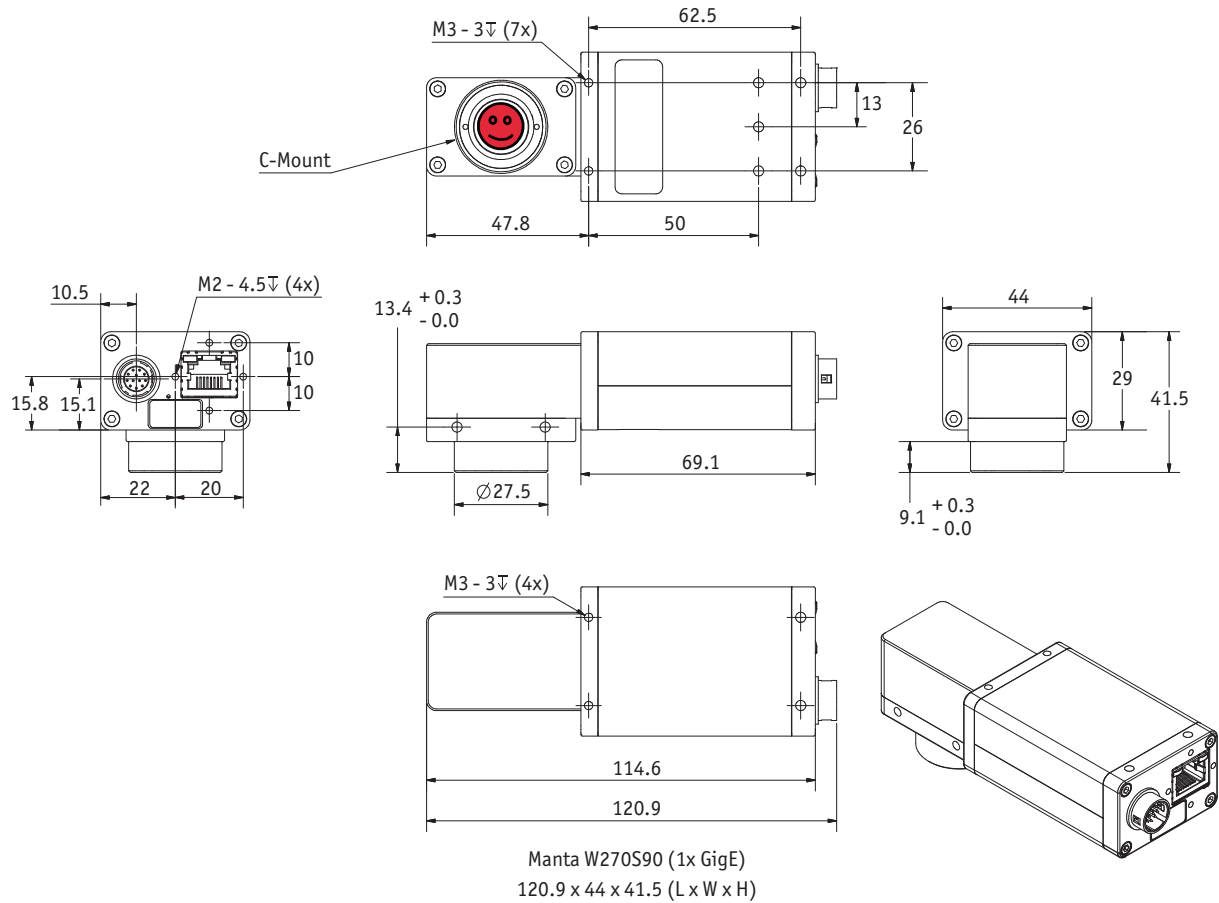

Figure 51: Camera dimensions Manta type A W270 S90 cameras: Manta G-031 / 032 / 033 / 046 / 095 / 125 / 145 / 146 / 201 / 504

Manta standard board level variants (type A)

Manta type A board level (non-PoE): dimensions

13-pole I/O connector:

- Molex PicoBlade
- Vertical Header 53047-1310
- Receptacle Housing 51021-1300
- Crimp Terminal 13 x 50079-8000

- 1 = GND (for RS232, Ext PWR)
- 2 = Ext PWR input
- 3 = Video Type Auto Iris Out
- 4 = Input 1
- 5 = not used
- 6 = Output 1
- 7 = GND (for Inputs)
- 8 = RxD 9 = TxD
- 10 = Power Input (for Output ports)
- 11 = Input 2
- 12 = Output 2
- 13 = Chassis GND

FFC45 cable length:

- FFC45 L = 56 mm K7500307
- FFC45 L = 110 mm K7500318
- FFC45 L = 152 mm 1817
- FFC45 L = 200 mm 1824

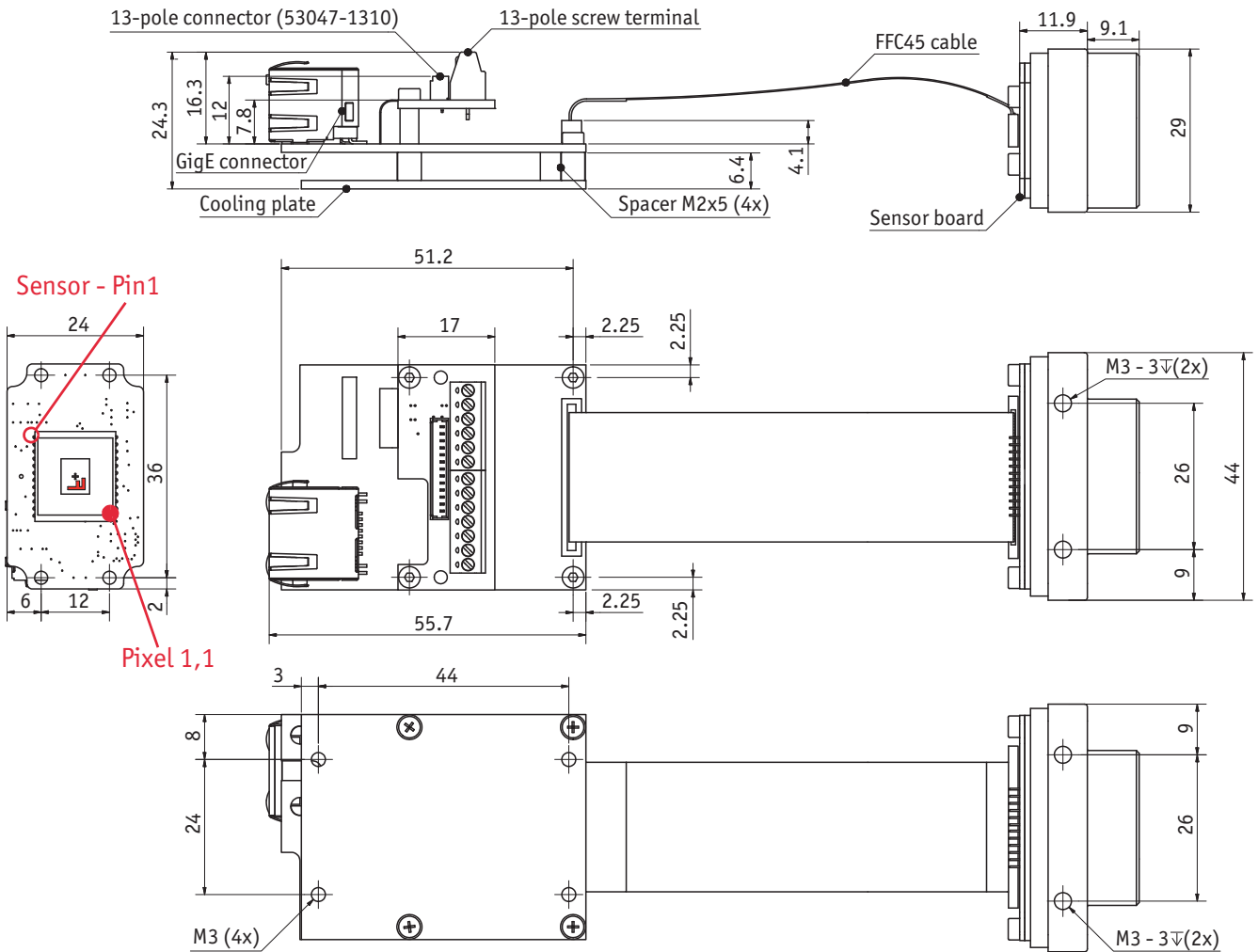

Figure 52: Dimensions for Manta type A board level (non-PoE): Manta G-031 / 032 / 033 / 046 / 095 / 125 / 145 / 146 / 201 / 504

Manta type A board level (PoE): dimensions

13-pole I/O connector:

Molex PicoBlade
 Vertical Header 53047-1310
 Receptacle Housing 51021-1300
 Crimp Terminal 13 x 50079-8000

1 = GND (for RS232, Ext PWR)	7 = GND (for Inputs)
2 = Ext PWR input	8 = RxD 9 = TxD
3 = Video Type Auto Iris Out	10 = Power Input (for Output ports)
4 = Input 1	11 = Input 2
5 = not used	12 = Output 2
6 = Output 1	13 = Chassis GND

FFC45 cable length:

FFC45 L = 56 mm	K7500307
FFC45 L = 110 mm	K7500318
FFC45 L = 152 mm	1817
FFC45 L = 200 mm	1824

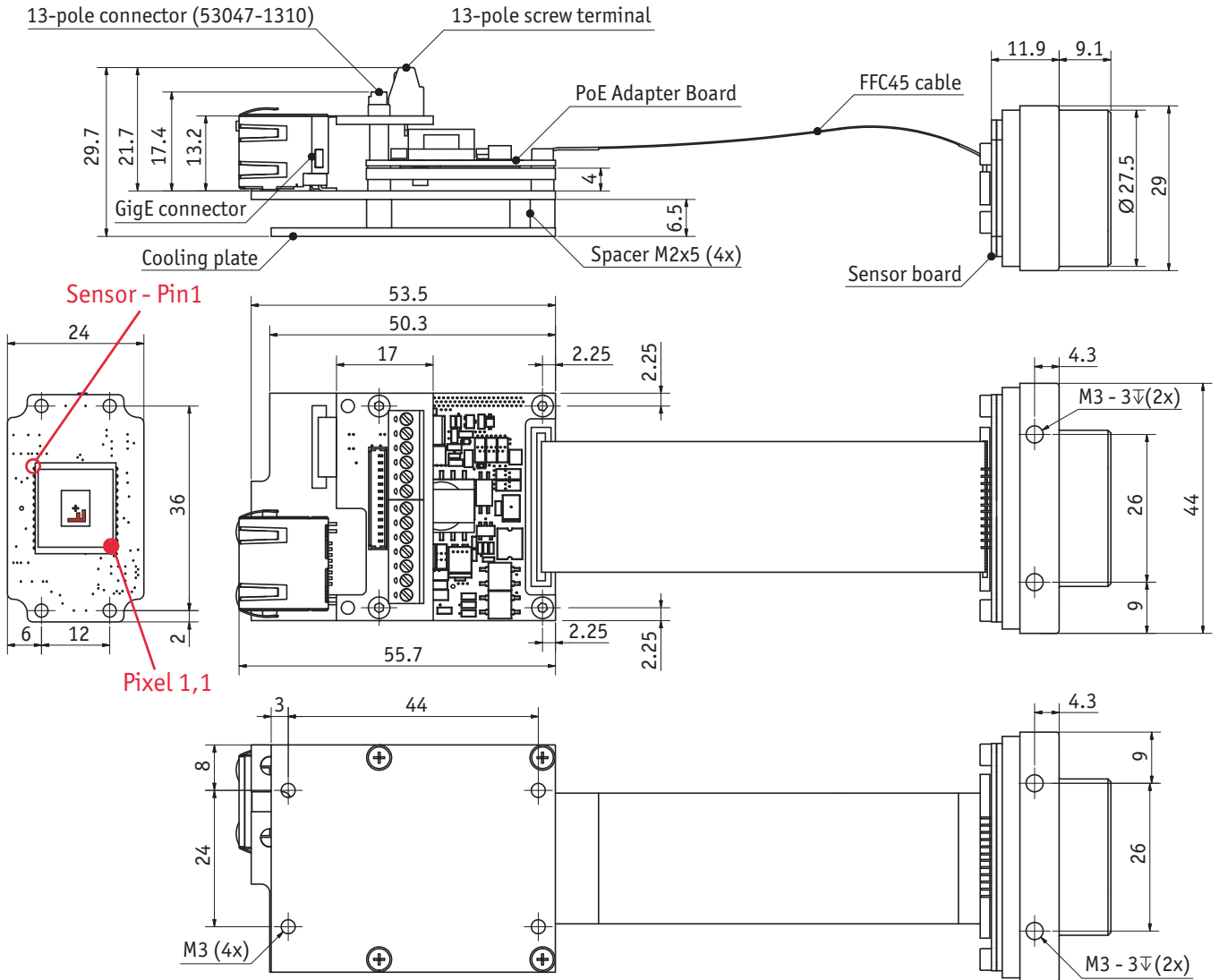

Figure 53: Dimensions for Manta type A board level (PoE): Manta G-031 / 032 / 033 / 046 / 095 / 125 / 145 / 146 / 201 / 504

Manta type A board level (non-PoE): C-Mount

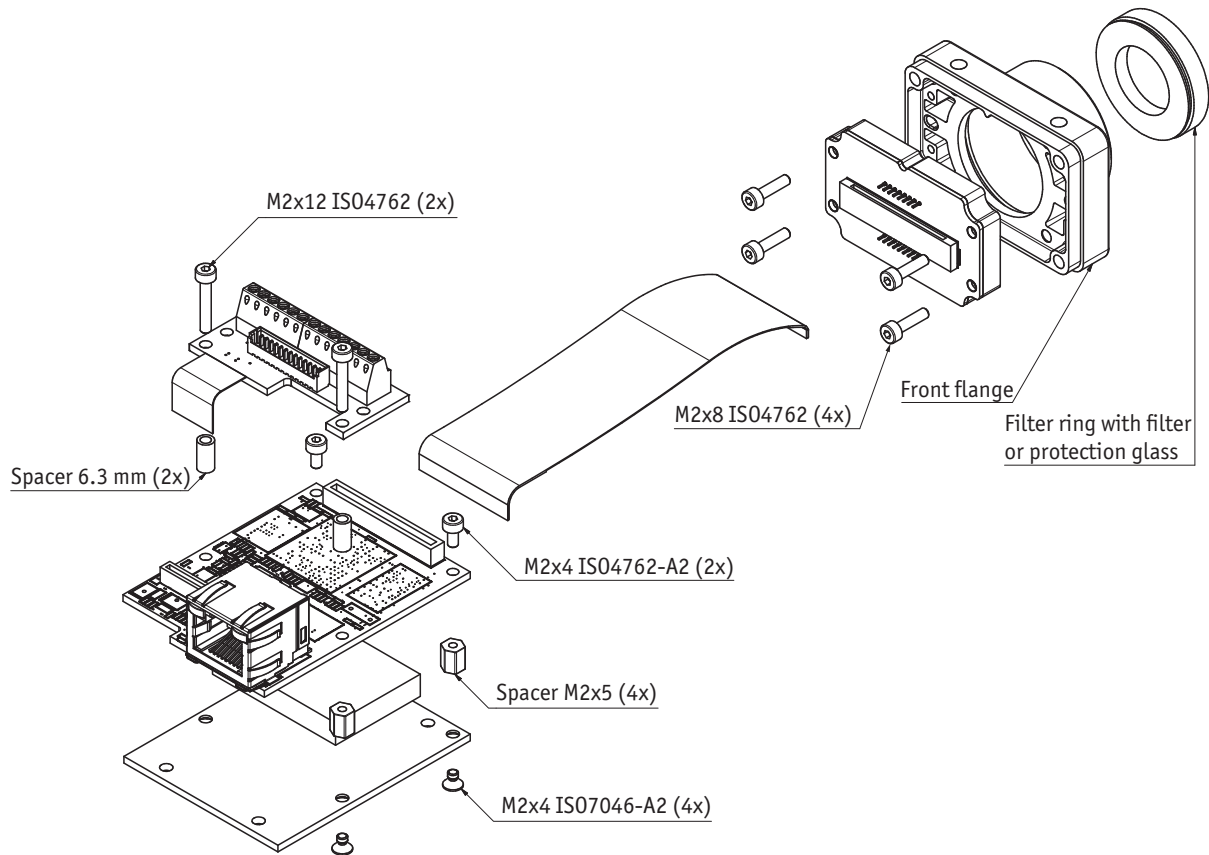

Figure 54: Manta type A board level (non-PoE): C-Mount

The dimensional adjustment cannot be done by the customer. All adjustments have to be done by the Allied Vision factory.

Note



If you need any adjustments, please contact Customer Care:

For phone numbers and e-mail:

See [Contacting Allied Vision](#) on page 7.

Manta type A board level (PoE): C-Mount

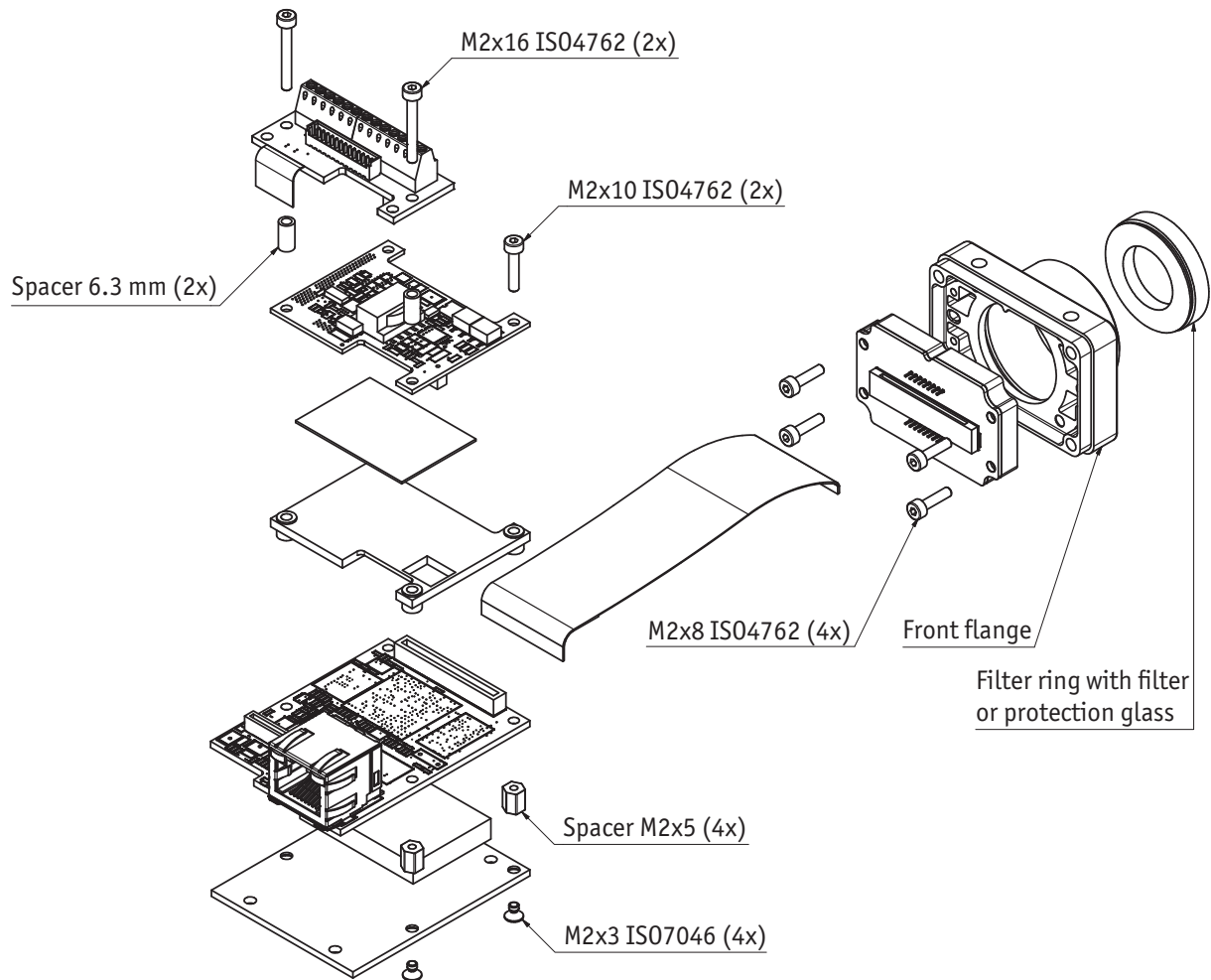

Figure 55: Manta type A board level (PoE): C-Mount

The dimensional adjustment cannot be done by the customer. All adjustments have to be done by the Allied Vision factory.

Note



If you need any adjustments, please contact Customer Care:
 For phone numbers and e-mail:
 See [Contacting Allied Vision](#) on page 7.

Manta type A board level (non-PoE): CS-Mount

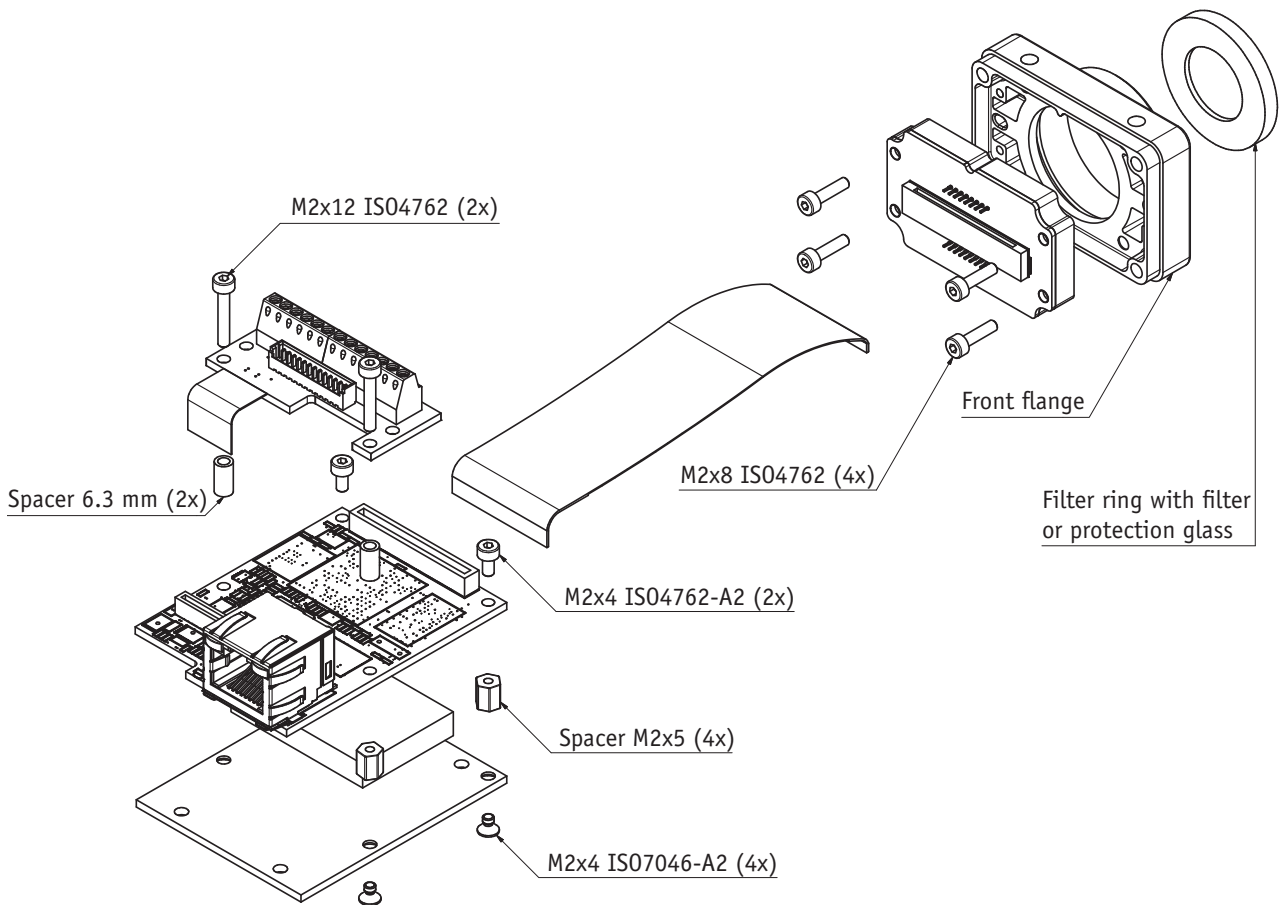

Figure 56: Manta type A board level (non-PoE): CS-Mount

The dimensional adjustment cannot be done by the customer. All adjustments have to be done by the Allied Vision factory.

Note



If you need any adjustments, please contact Customer Care:

For phone numbers and e-mail:

See [Contacting Allied Vision](#) on page 7.

Manta type A board level (PoE): CS-Mount

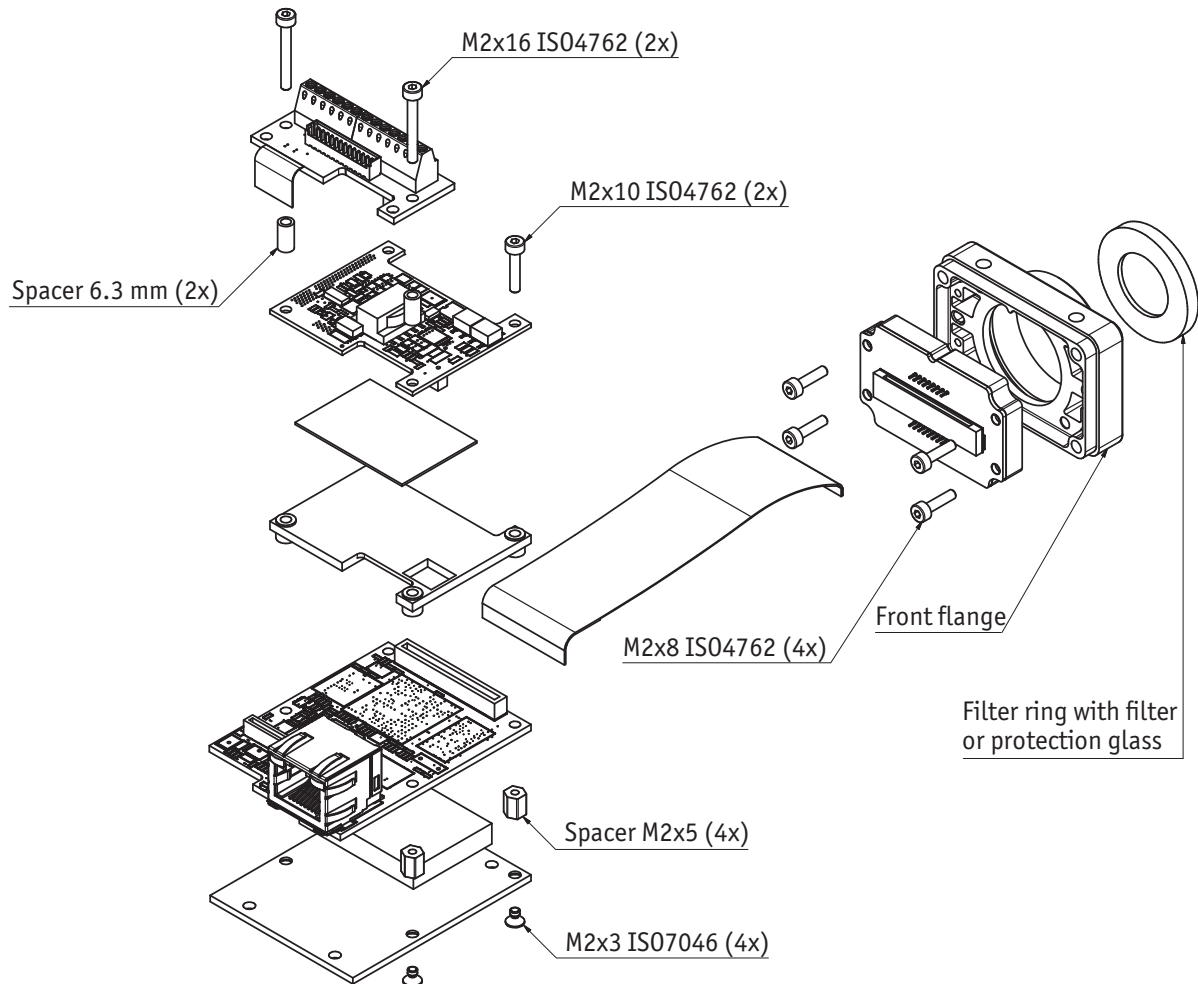

Figure 57: Manta type A board level (PoE): CS-Mount

The dimensional adjustment cannot be done by the customer. All adjustments have to be done by the Allied Vision factory.

Note



If you need any adjustments, please contact Customer Care:
 For phone numbers and e-mail:
 See [Contacting Allied Vision](#) on page 7.

Manta type A board level (non-PoE): M12-Mount

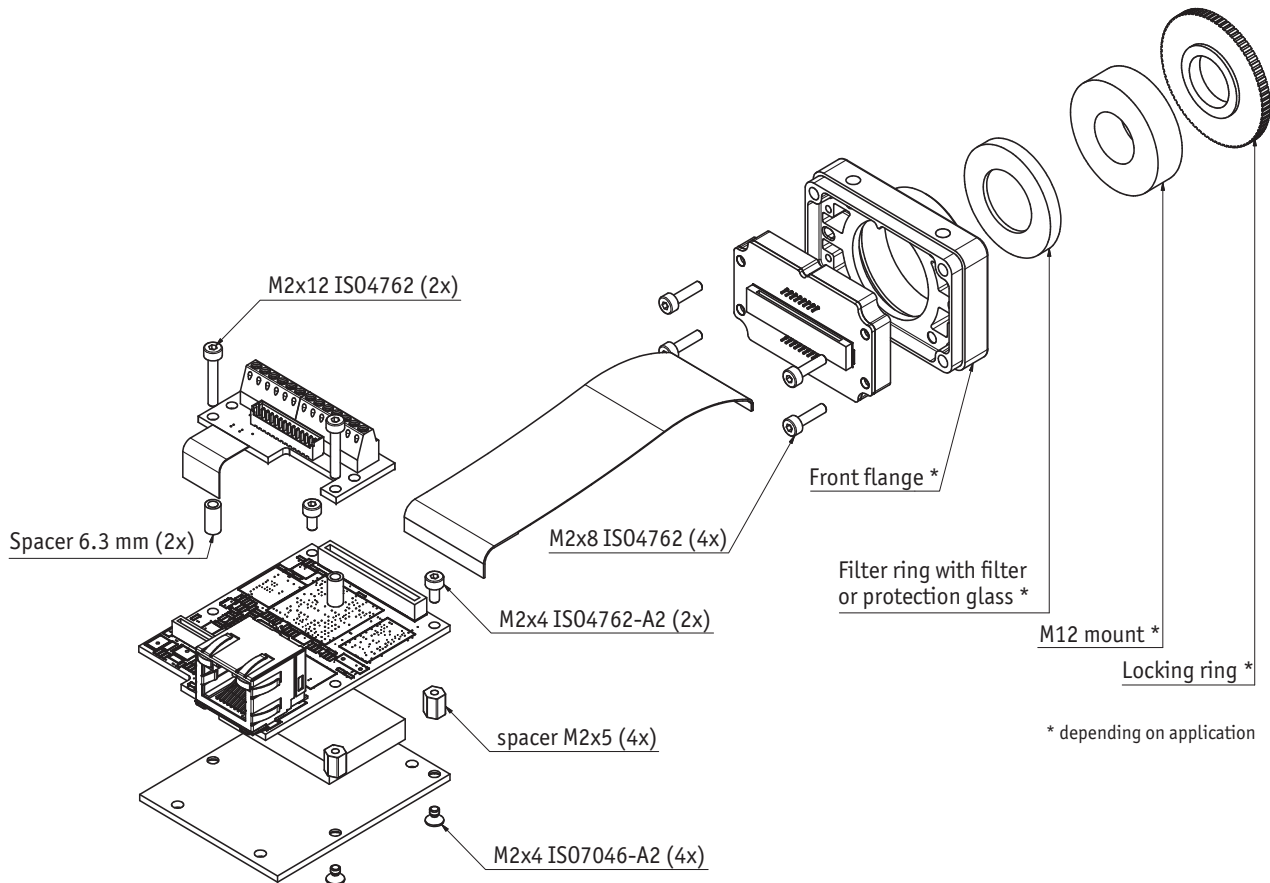

Figure 58: Manta type A board level (non-PoE): M12-Mount

The dimensional adjustment cannot be done by the customer (depending on application). All adjustments have to be done by the Allied Vision factory.

Note



If you need any adjustments, please contact Customer Care:

For phone numbers and e-mail:

See [Contacting Allied Vision](#) on page 7.

Manta type A board level (PoE): M12-Mount

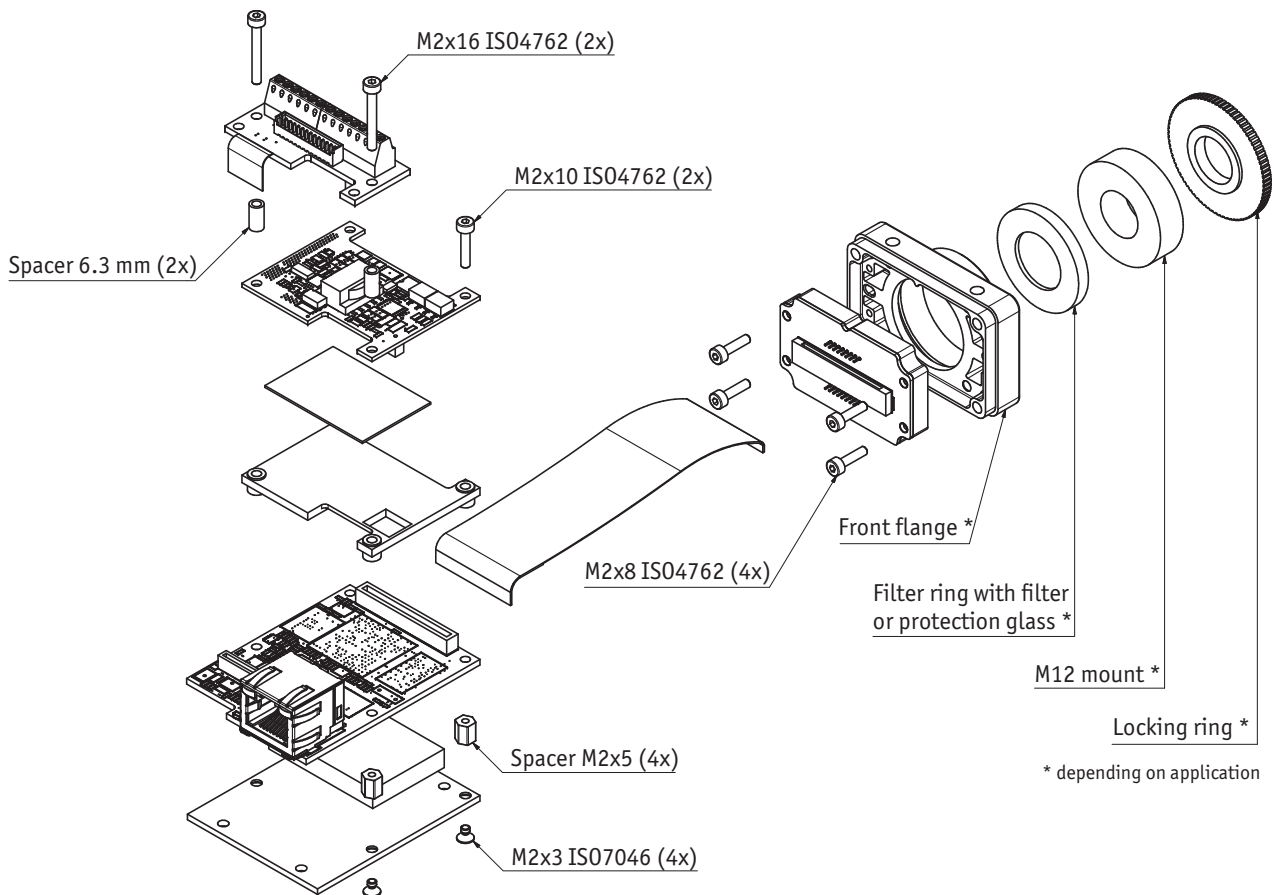

Figure 59: Manta type A board level (PoE): M12-Mount

The dimensional adjustment cannot be done by the customer (depending on application). All adjustments have to be done by the Allied Vision factory.

Note



If you need any adjustments, please contact Customer Care:

For phone numbers and e-mail:

See [Contacting Allied Vision](#) on page 7.

Cross section: C-Mount (type A)

- All monochrome Manta type A cameras are equipped with a protection glass.
- All color Manta type A cameras are equipped with the same [IR cut filter](#).

Note **Maximum protrusion** means the distance from lens flange to the glass filter in the camera.

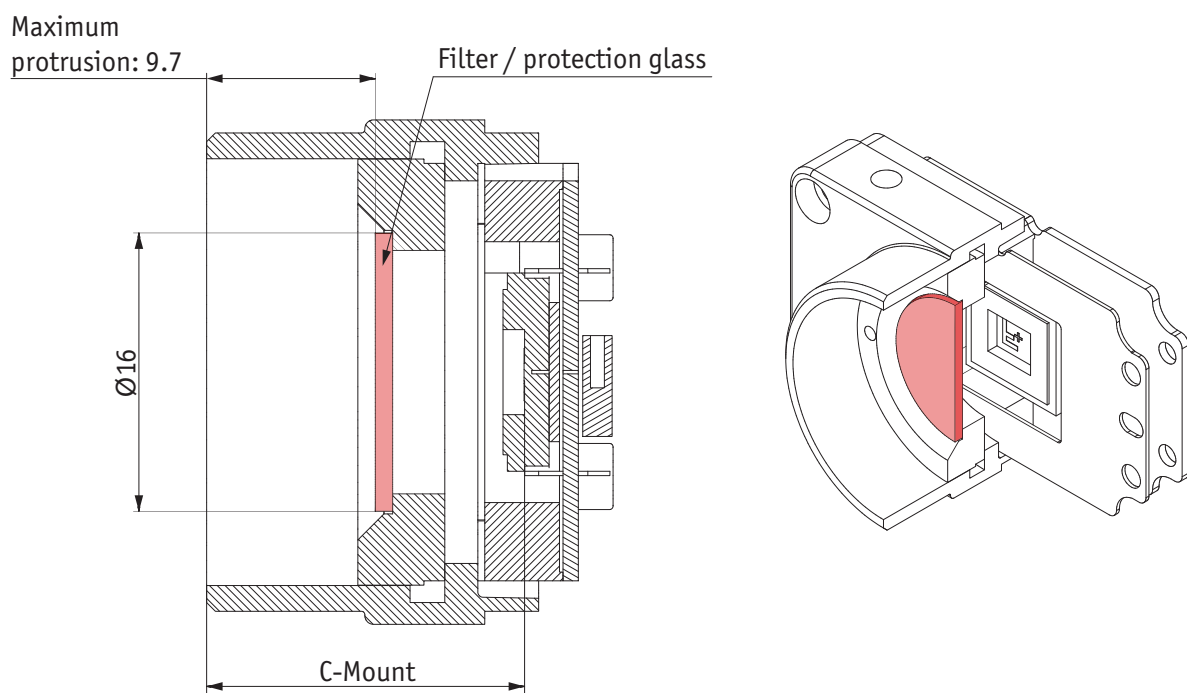

Figure 60: Manta C-Mount dimensions (16 mm filter, type A)

Adjusting C-Mount

The dimensional adjustment cannot be done by the customer. All modifications have to be done by the Allied Vision factory.

Note **If you need any modifications, please contact Customer Care:** For phone numbers and e-mail: See [Contacting Allied Vision](#) on page 7.



Cross section: CS-Mount (type A)

www

Choose protection glass or filter according to the **Modular Concept**.



http://www.alliedvision.com/fileadmin/content/documents/products/cameras/various/modular-concept/Modular_concept_external.pdf

Note

Maximum protrusion means the distance from lens flange to the glass filter in the camera.

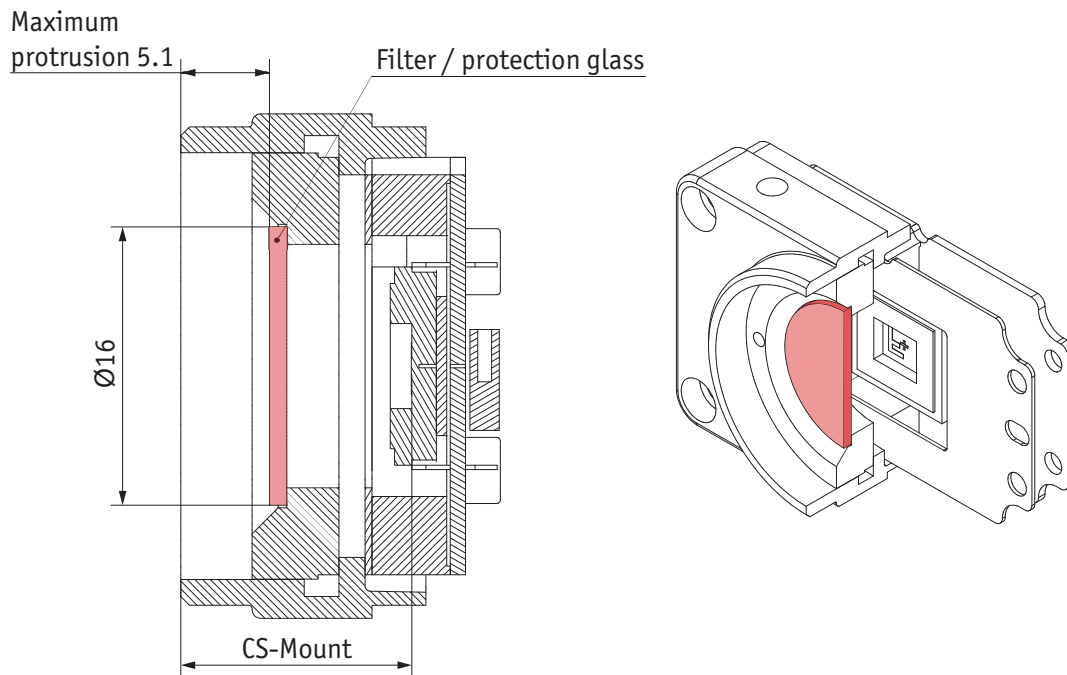

Figure 61: Manta CS-Mount dimensions (type A)

Adjusting CS-Mount

The dimensional adjustment cannot be done by the customer. All modifications have to be done by the Allied Vision factory.

Note

If you need any modifications, please contact Customer Care. For phone numbers and e-mail: See [Contacting Allied Vision](#) on page 7.



Camera dimensions (type B)

Note Manta type A cameras have different housings than Manta type B cameras.



Manta type A cameras: G-031 / 032 / 033 / 046 / 095 / 125 / 145 / 146 / 201 / 504, see [Camera dimensions \(type A\)](#) on page 71.

Manta type B cameras: G-223 / 235 / 282 / 283 / 419 / 505 / 609 / 917.

Note For information on sensor position accuracy:



See [Sensor position accuracy of Manta cameras](#) on page 152.

Note For information on **camera dimensions for non-PoE Manta cameras up to serial number 503323258:**



See [Exceptions for non-PoE Manta cameras up to serial number 503323258](#) on page 153.

Tripod adapter

This five hole tripod adapter (Allied Vision order number 5153) can be used for Manta cameras (type A and type B) and is only designed for standard housings.

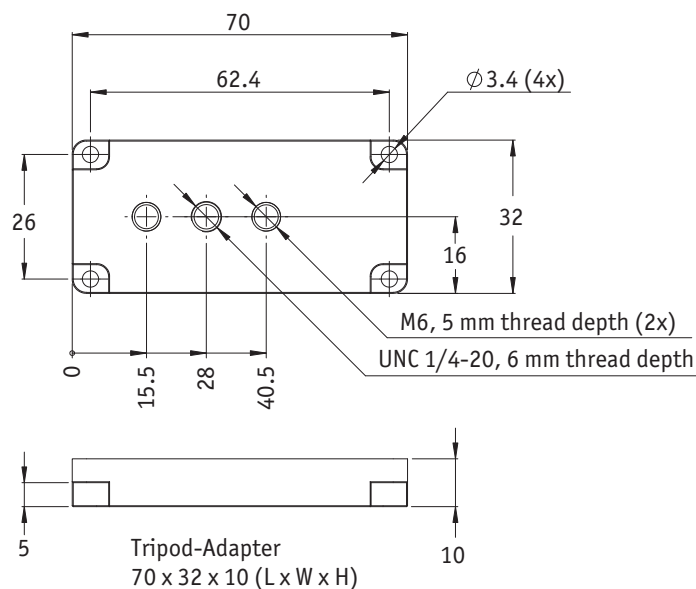

Figure 62: Tripod dimensions

Manta standard housing (type B)

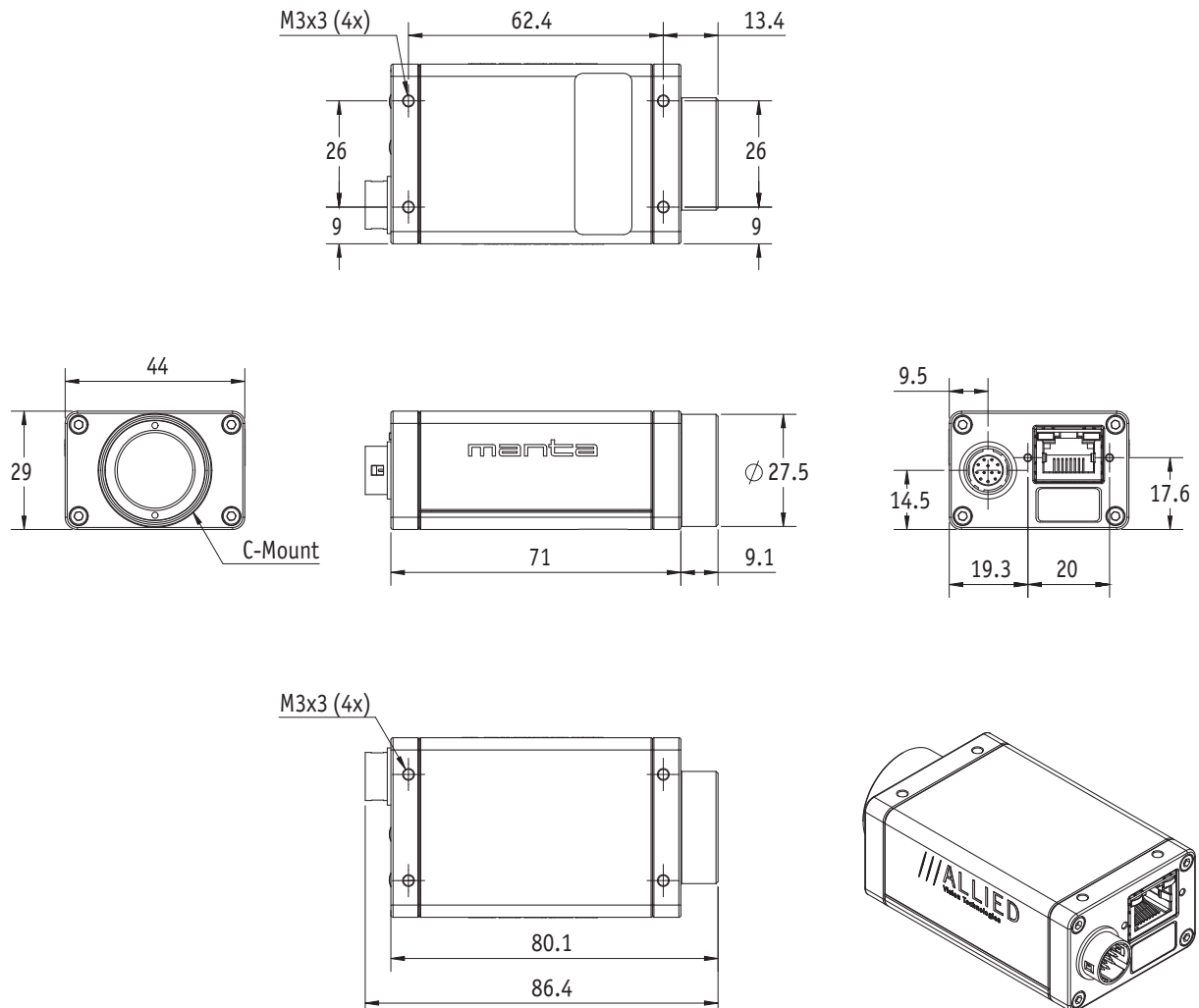

Figure 63: Camera dimensions type B cameras: Manta G-223 / 235 / 282 / 283 / 419 / 505 / 609 / 917

Manta CMOS angled-head housings (type B)

Manta W90

This version has the sensor tilted by 90 degrees clockwise, so that it views upwards.

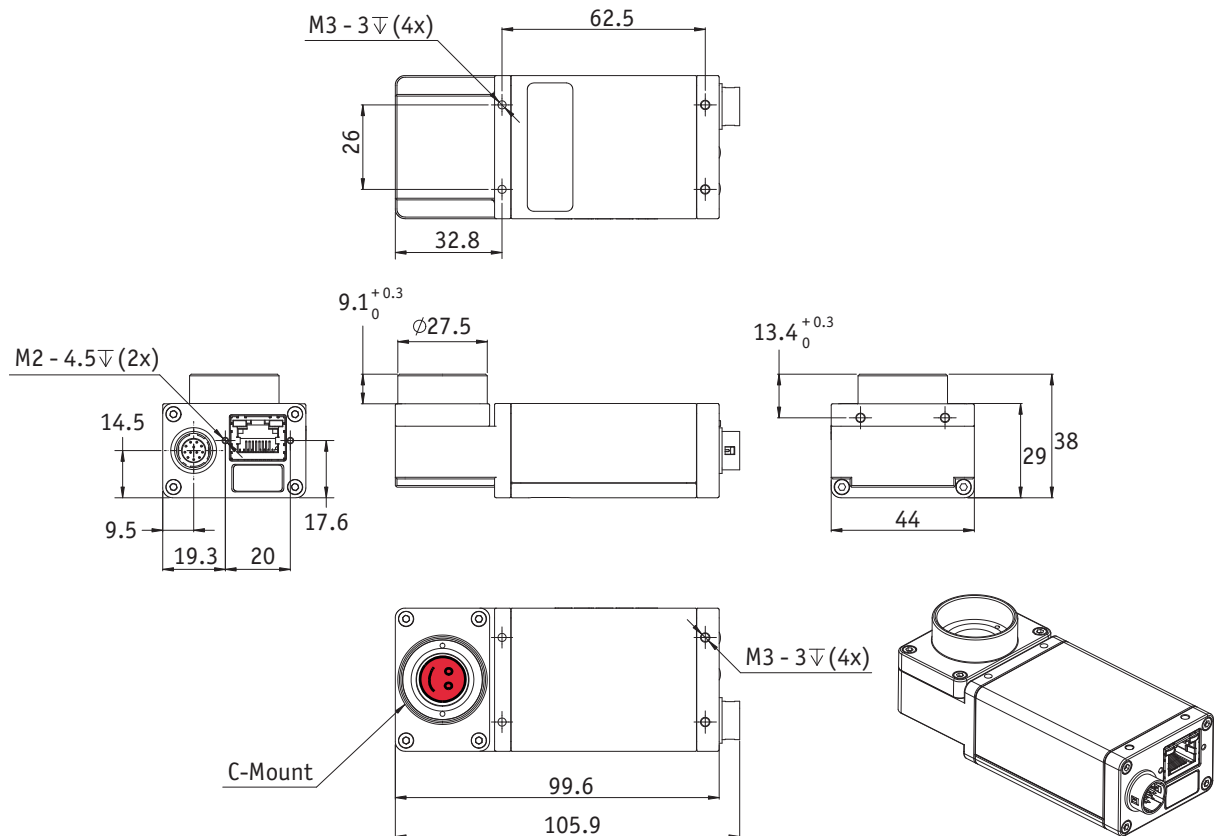

Figure 64: Camera dimensions W90 cameras: Manta G-223 / 235 / 419

Manta W90 S90

This version has the sensor tilted by 90 degrees clockwise, so that it views upwards.

The sensor is also rotated by 90 degrees clockwise.

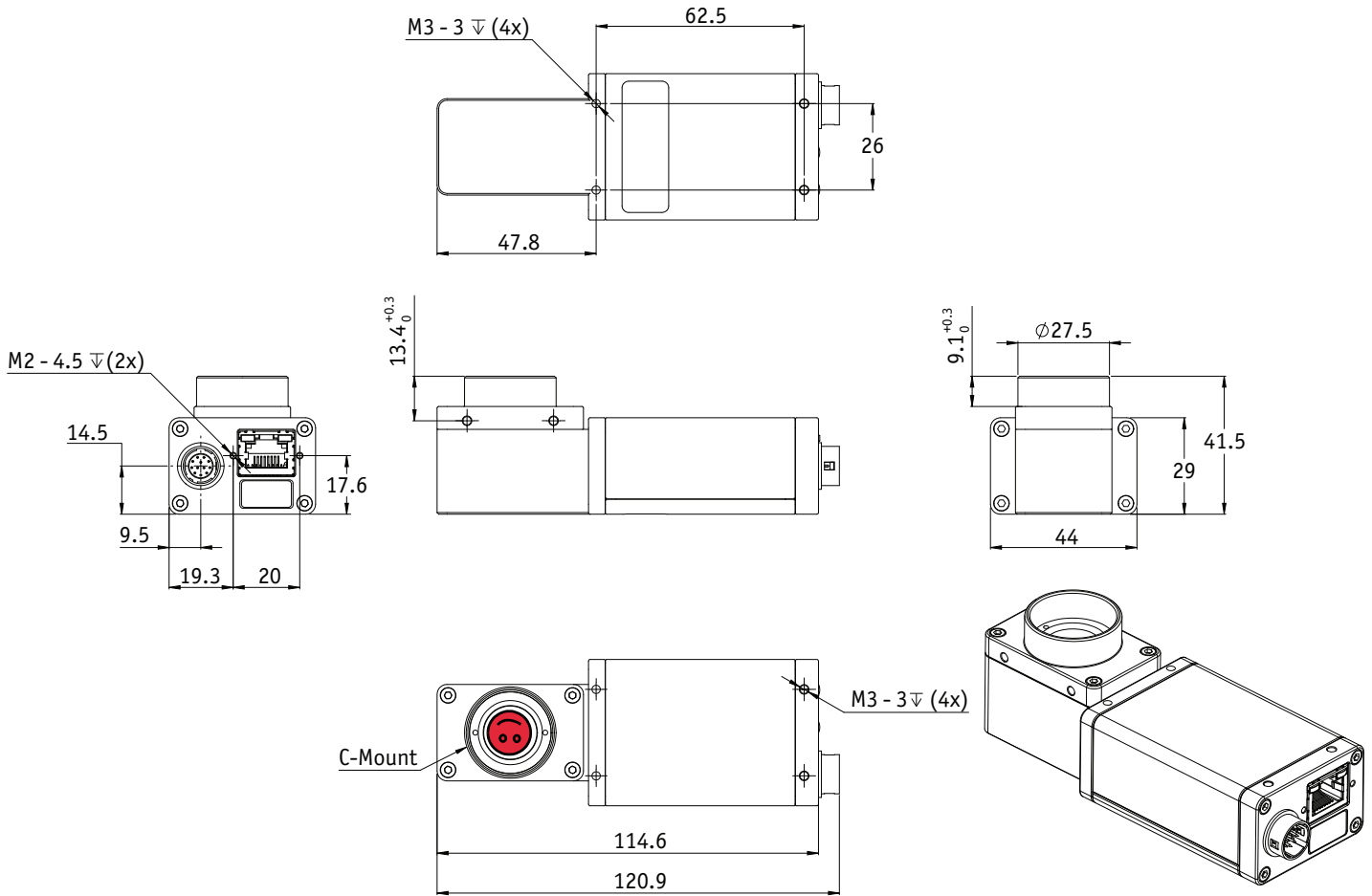

Figure 65: Camera dimensions W90 S90 cameras: Manta G-223 / 235 / 419

Manta W270

This version has the sensor tilted by 270 degrees clockwise, so that it views downwards.

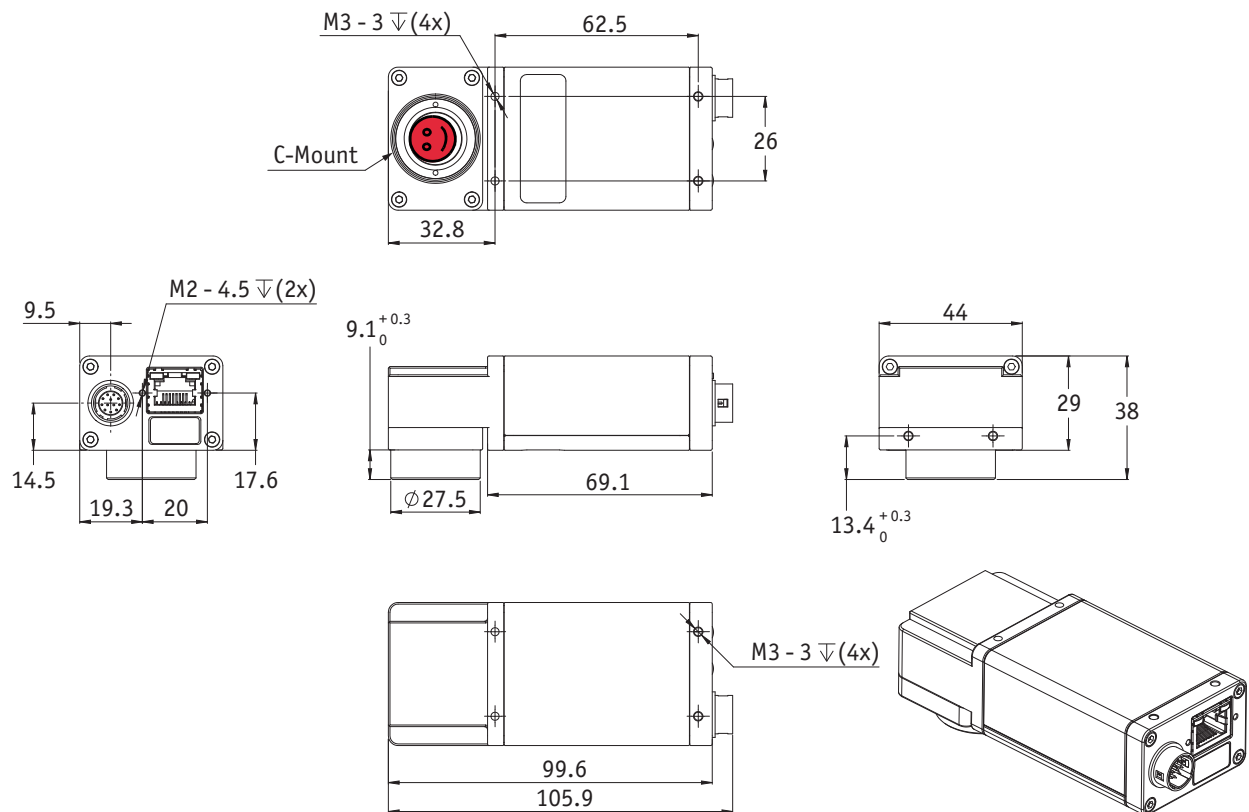

Figure 66: Camera dimensions W270 cameras: Manta G-223 / 235 / 419

Manta W270 S90

This version has the sensor tilted by 270 degrees clockwise, so that it views downwards.

The sensor is also rotated by 90 degrees clockwise.

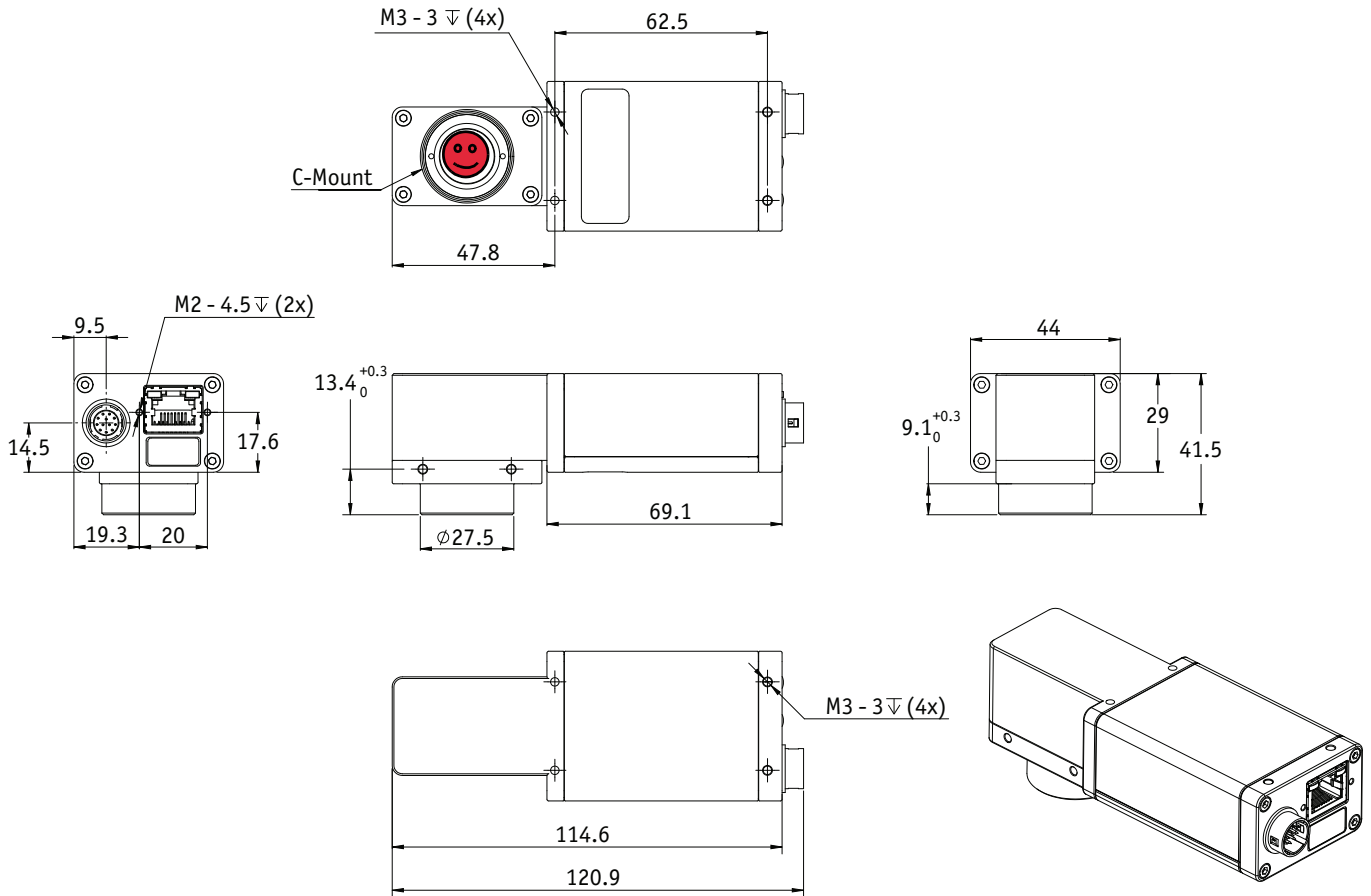

Figure 67: Camera dimensions W270 S90 cameras: Manta G-223 / 235 / 419

Manta CMOS board level variants (type B)

Manta CMOS board level cameras: dimensions

13-pole I/O connector:
Molex PicoBlade
Vertical Header 53047-1310
Receptacle Housing 51021-1300
Crimp Terminal 13 x 50079-8000

1 = GND (for RS232, Ext PWR)
2 = Ext PWR input
3 = Video Type Auto Iris Out
4 = Input 1
5 = not used
6 = Output 1

7 = GND (for Inputs)
8 = Rx/D 9 = Tx/D
10 = Power Input (for Output ports)
11 = Input 2
12 = Output 2
13 = Chassis GND

Flex cable length:

FPC80 L = 60 mm 5568-01
FPC80 L = 110 mm 5569-01
FPC80 L = 150 mm 5570-01
FPC80 L = 200 mm 5571-01

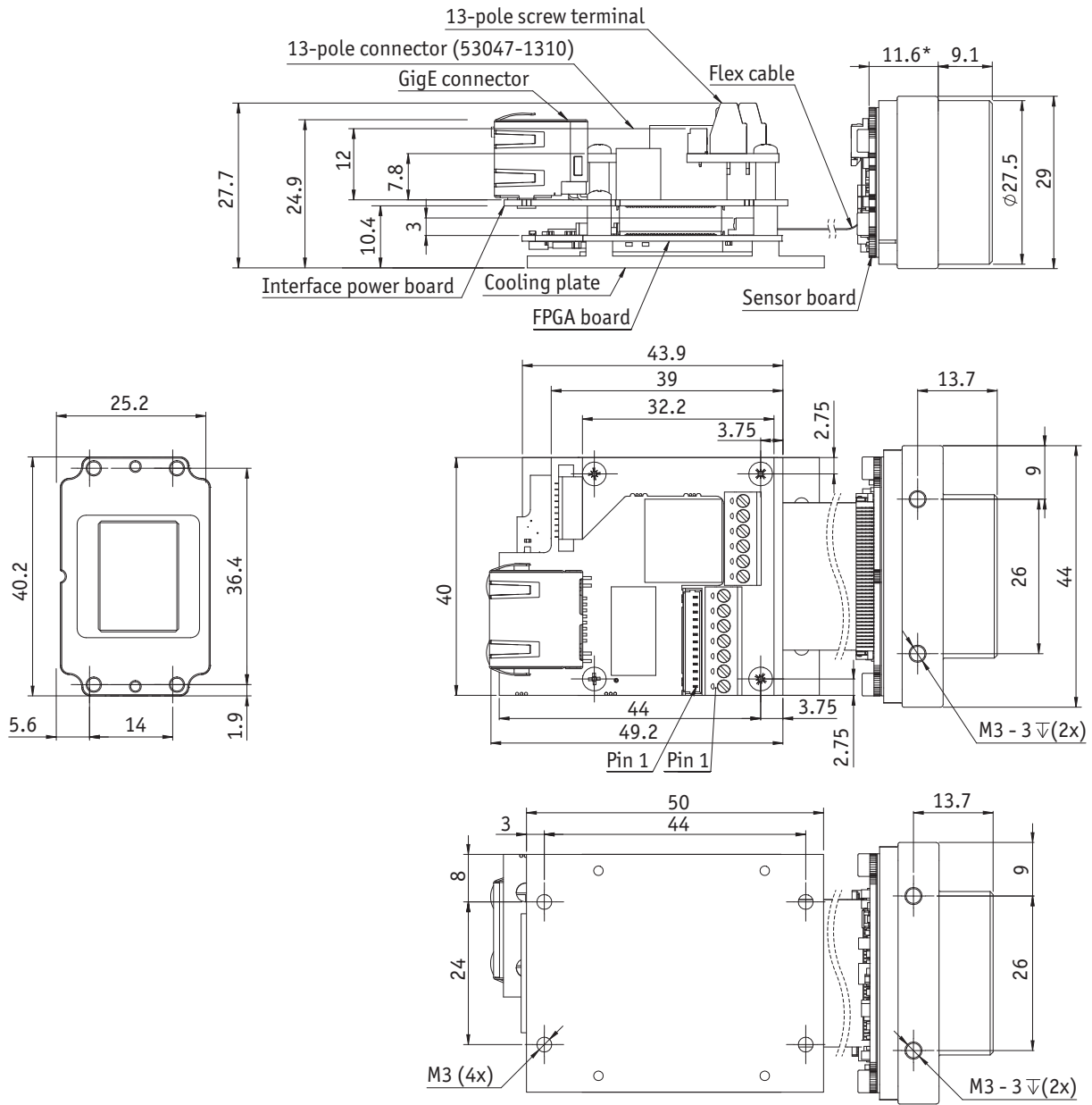

*Depending upon the sensor

Figure 68: Board level (non-PoE and PoE) dimensions for Manta G-223 / 235 / 419

Manta CMOS (type B) board level cameras: C-Mount

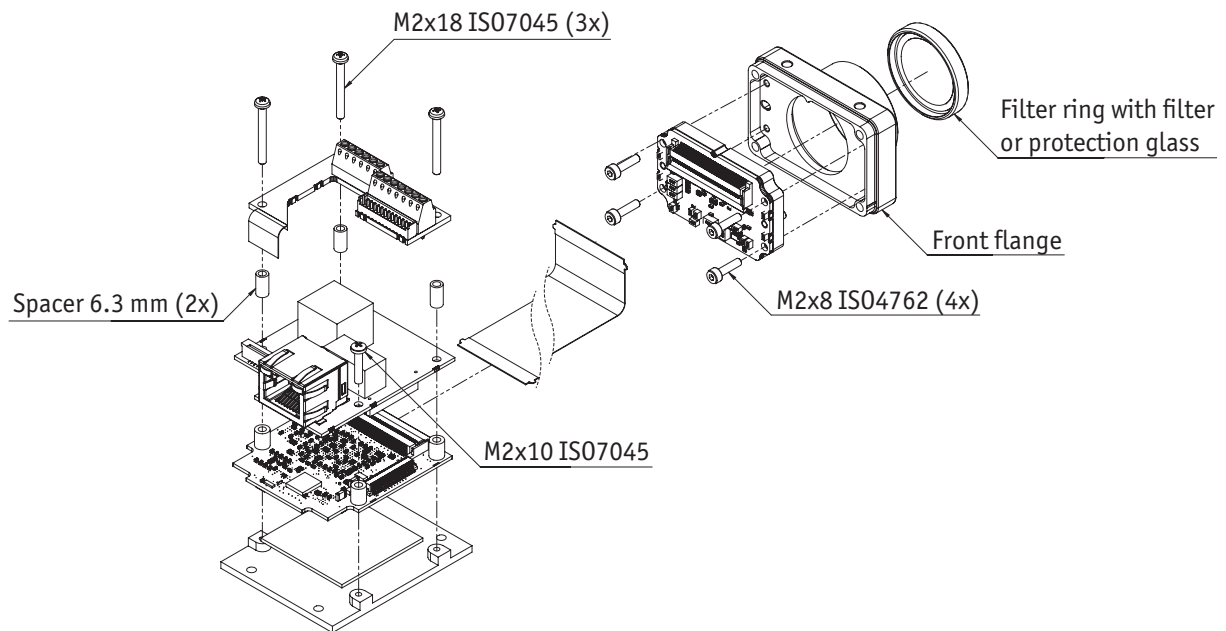

Figure 69: Board level (non-PoE and PoE) for Manta G-223 / 235 / 419: C-Mount

The dimensional adjustment cannot be done by the customer. All adjustments have to be done by the Allied Vision factory.

Note



If you need any adjustments, please contact Customer Care:
 For phone numbers and e-mail:
 See [Contacting Allied Vision](#) on page 7.

Manta CMOS (type B) board level cameras: CS-Mount

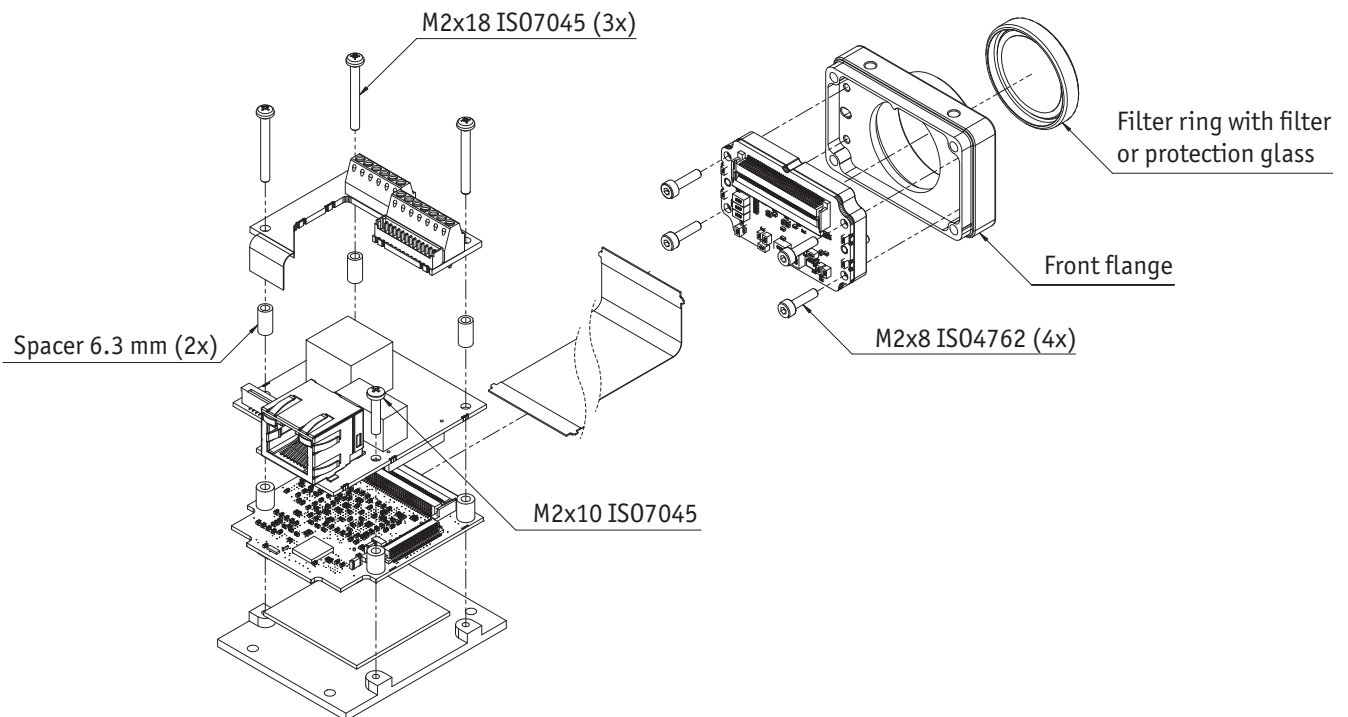

Figure 70: Board level (non-PoE and PoE) for Manta G-223 / 235 / 419: CS-Mount

The dimensional adjustment cannot be done by the customer. All adjustments have to be done by the Allied Vision factory.

Note



If you need any adjustments, please contact Customer Care:
For phone numbers and e-mail:
See [Contacting Allied Vision](#) on page 7.

Manta CMOS (type B) board level cameras: M12-Mount

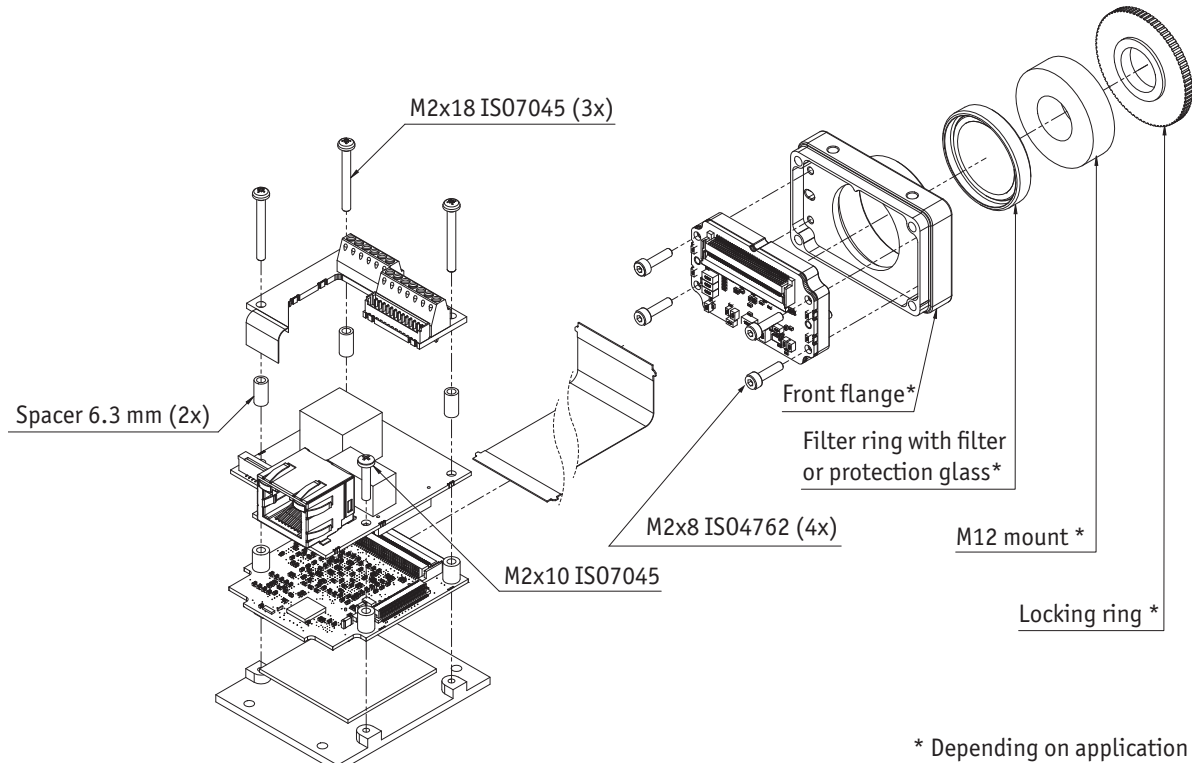

Figure 71: Board level (non-PoE and PoE) for Manta G-223 / 235 / 419: M12-Mount

The dimensional adjustment cannot be done by the customer. All adjustments have to be done by the Allied Vision factory.

Note



If you need any adjustments, please contact Customer Care:
 For phone numbers and e-mail:
 See [Contacting Allied Vision](#) on page 7.

Cross section: C-Mount (type B)

Manta (type B) cameras with sensor size $\geq 1"$ diagonal are equipped with a 22 mm diameter filter / protection glass. All other Manta (type B) cameras are equipped with a 16 mm diameter filter / protection glass.

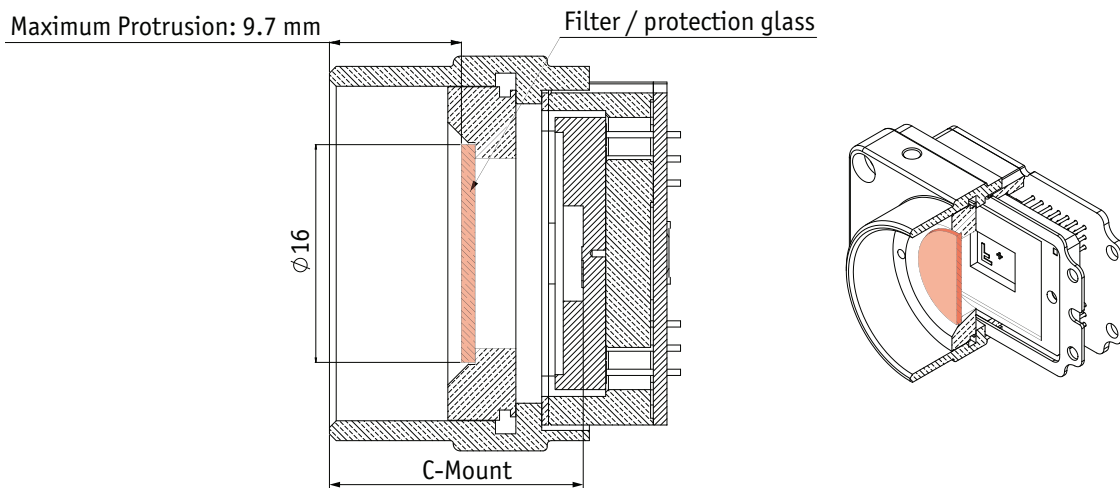

Figure 72: C-Mount dimensions (16 mm filter) for Manta G- 235 / 282 / 283 / 505

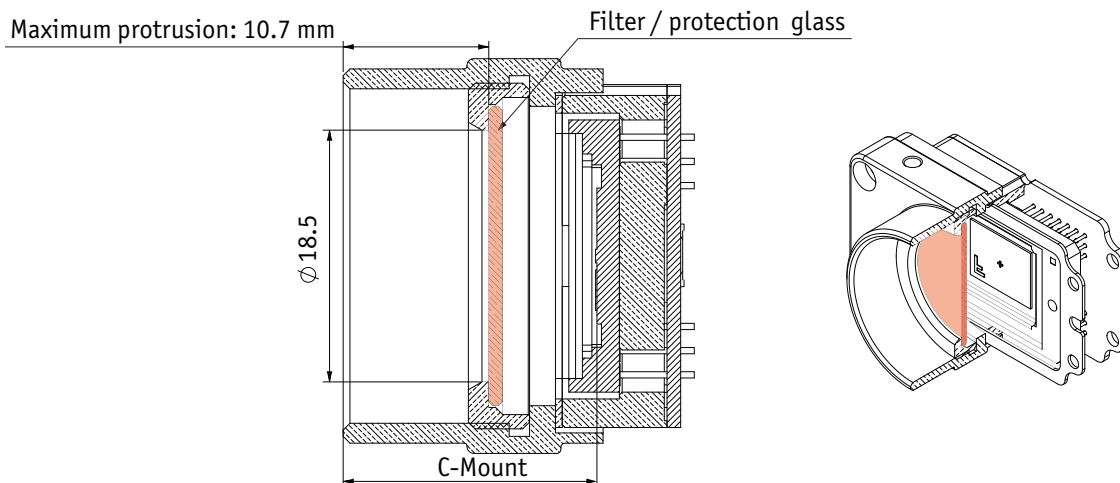

Figure 73: C-Mount dimensions (22 mm filter) for Manta G-223 / 419/ 609 /917

Adjusting C-Mount

The dimensional adjustment cannot be done by the customer. All modifications have to be done by the Allied Vision factory.

Note



If you need any modifications, please contact Customer Care: For phone numbers and e-mail: See [Contacting Allied Vision](#) on page 7.

Cross section: CS-Mount (type B)

Manta (type B) cameras with sensor size $\geq 1"$ diagonal are equipped with a 22 mm diameter filter / protection glass. All other Manta (type B) cameras are equipped with a 16 mm diameter filter / protection glass.

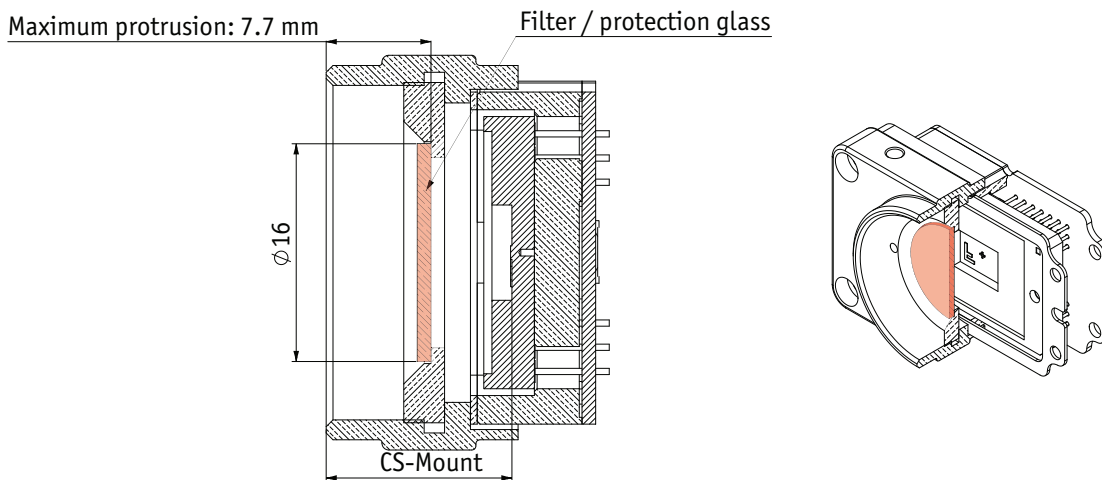

Figure 74: CS-Mount dimensions (16 mm filter) for Manta G- 235 / 282 / 283 / 505

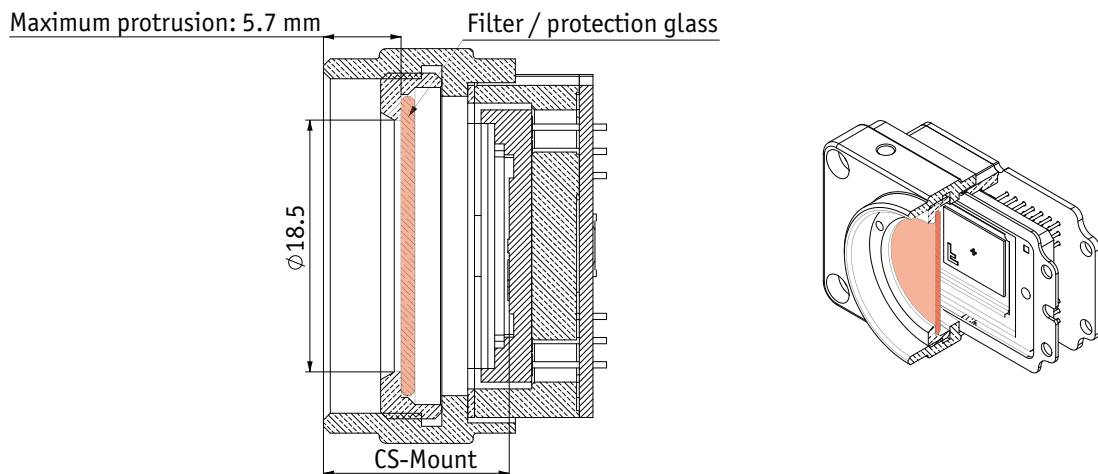

Figure 75: CS-Mount dimensions (22 mm filter) for Manta G-223 / 419/ 609 /917

Adjusting CS-Mount

The dimensional adjustment cannot be done by the customer. All modifications have to be done by the Allied Vision factory.

Note



If you need any modifications, please contact Customer Care: For phone numbers and e-mail: See [Contacting Allied Vision](#) on page 7.

Camera interfaces

This chapter gives you information on Gigabit Ethernet port, inputs and outputs and trigger features.

Gigabit Ethernet port

The Gigabit Ethernet port conforms to the IEEE 802.3 1000BASE-T standard for Gigabit Ethernet over copper. To prevent EMI (electromagnetic interference) and for best performance, Category 6 (or higher) cables with S/STP shielding and connectors are recommended.

Note



- Cable lengths up to 100 m are supported.
- The 8-pin RJ-45 jack has the pin assignment according to the Ethernet standard (IEEE 802.3 1000BASE-T).
- For cameras that are **PoE** capable, the GigE connector can be used to provide power to the camera.
- Manta **PoE** models can source power
 - from 802.3af (1000 MBit/s) and
 - from 802.3at compliant PSE devices (Power Sourcing Equipment): such as switches injectors or NICs.
- If both interfaces are used for power (I/O and GigE connector via **PoE**), the camera will only use the power from the I/O connector.

Same main board for all Manta models

From serial number **503323258** on all Manta models including PoE and board level versions contain the same main board.

PoE and non PoE

- How can I distinguish between PoE capable cameras and cameras that are not PoE capable?
 - **PoE** capable cameras have the letters **PoE** written on the camera's label on the back side and the bottom side of the camera.

www



Accessories:

Please contact Allied Vision sales representative or your local Allied Vision dealer for information on accessories offered by Allied Vision:

<http://www.alliedvision.com/en/about-us/where-we-are.html>

Camera I/O connector pin assignment (incl. PoE)

Note



From serial number **503323258** onwards all Manta models including PoE and board level versions contain the same main board:

- All I/O circuits have the same properties.
- For **Manta models with serial number ≤ 503323258** : see [Camera I/O connector pin assignment](#) on page 159.

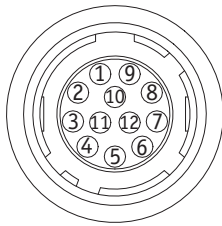

Pin	Signal	Direction	Level	Description
1	Camera GND	In	GND for RS232 and ext. power	Ground for camera power supply and RS232
2	Camera Power	In	8–30 V DC	Camera power supply
3	Video Type Auto Iris Out	Out	---	Video type auto iris (\geq FW 1.44)
4	In 1	In	Standard and PoE cameras: $U_{in}(high) = 3-24\text{ V}$ up to 36 V with external resistor of 3.3 k Ω in series $U_{in}(low) = 0-1.0\text{ V}$	Input 1 (SyncIn1)
5	---	---	---	---
6	Out 1	Out	Open emitter, max. 10 mA	Output 1 (SyncOut1)
7	Isolated IO GND	In/Out	Common GND for In/Out	Isolated input and output signal ground
8	RxD RS232	In	RS232	Terminal receive data
9	TxD RS232	Out	RS232	Terminal transmit data
10	Isolated Out Power	In	Common VCC for outputs max. 30 V DC	Power input for opto-isolated outputs
11	In 2	In	Standard and PoE cameras: $U_{in}(high) = 3-24\text{ V}$ $U_{in}(low) = 0-1.0\text{ V}$	Input 2 (SyncIn2)
12	Out 2	Out	Open emitter, max. 10 mA	Output 2 (SyncOut2)

Table 36: Camera I/O connector pin assignment

Note



Read all **Notes** and **Cautions** in the [GigE Installation Manual](#) before using the I/O connector.

The General Purpose I/O port uses a Hirose HR10-10R-12PA(73) connector on the camera side. The mating cable connector is Hirose HR10A-10P-12S.

Note



The cable side Hirose connector is available for purchase from Allied Vision.

P/N: K7600040

Manta input block diagram

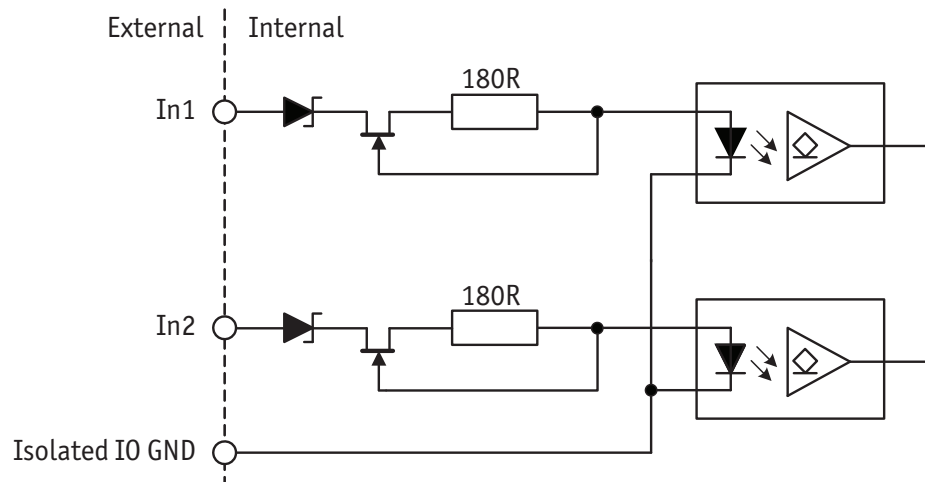

Figure 76: Manta input block diagram

The inputs can be connected directly to the system for voltages up to 24 V DC. An external resistor is not necessary.

Note



For customers who designed their system for Manta cameras with serial numbers prior to the above mentioned hardware change:

Use your systems with an external resistor without any restrictions.

Parameter	Value
U_{in} (low)	0–1.0 V
U_{in} (high)	3–24 V
Current (constant-current source)	3–4 mA

Table 37: Manta input parameters

Manta delay and minimum pulse width

The **minimum pulse width** for all Manta cameras is:

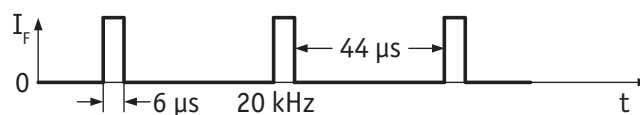

Figure 77: Manta minimum pulse width

Test conditions

The input signal was driven with 3.3 V and no external additional series resistor.

Manta output block diagram

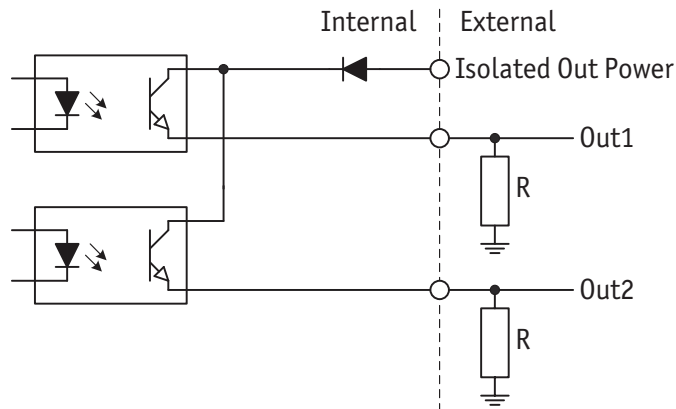

Figure 78: Manta: output block diagram

Caution



- Max. 10 mA per output
- **Isolated Out Power** > 30 V may damage the camera.

Isolated Out Power	Resistor value*	
5 V	1.0 kΩ	at ~ 5 mA minimum required current draw
12 V	2.4 kΩ	
24 V	4.7 kΩ	

* Resistor required if Out1/2 connected to a device with < 5 mA draw, i.e. high impedance

Table 38: Manta - **Isolated Out Power** and external resistor

Manta delay

The cycle delay for all Manta cameras is:
 $t_{pdLH} < 3.5 \mu s$ and $t_{pdHL} < 30 \mu s$

Note



For this reason, we recommend to trigger on the rising edge. This guarantees a reaction time that is as fast as possible.

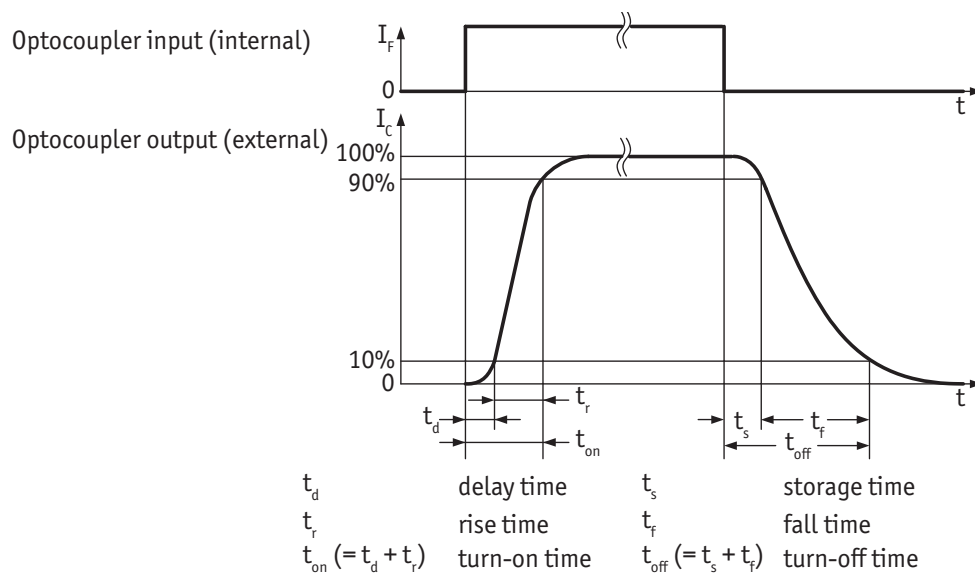

Figure 79: Manta output switching times

For all Manta models:

Parameter and value	
$t_d \approx 1 \mu\text{s}$	$t_s \approx 26 \mu\text{s}$
$t_r \approx 1 \mu\text{s}$	$t_f \approx 21 \mu\text{s}$
$t_{on} = t_d + t_r \approx 2 \mu\text{s}$	$t_{off} = t_s + t_f \approx 47 \mu\text{s}$ (t_{off} can deviate by $\pm 5 \mu\text{s}$)

Table 39: Parameters for Manta

Test conditions

Output: external 2.4 k Ω resistor to GND, **Isolated Out Power** set to 12 V.

Note Higher external values increase the times in the table above.



Status LEDs

Note



For detailed description of **status LEDs of non-PoE Manta cameras up to serial number 503323258** see: [Status LEDs](#) on page 160.

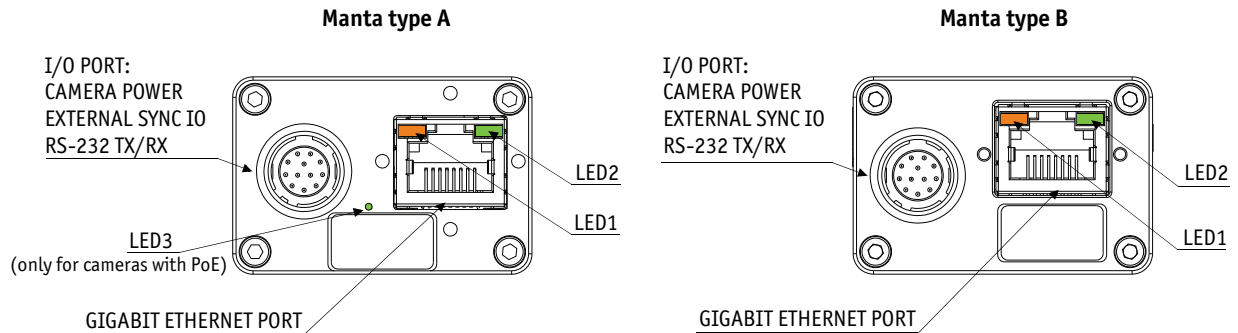

Figure 80: Rear view of Manta camera type A (*left*) and type B (*right*)

Status LEDs Manta type A

The tables below describe the status LEDs of Manta type A (G-031 / 032 / 033 / 046 / 095 / 125 / 145 / 146 / 201 / 504) cameras.

LED 1 color	Status
Solid orange	Ethernet link with 1 Gbit/s established
Flashing orange	Ethernet activity with 1 Gbit/s

Table 40: Status LED 1 (**orange**)

LED 2 color	Status
Solid green	Ethernet link with 100 Mbit/s established
Flashing green	Ethernet activity with 100 Mbit/s

Table 41: Status LED 2 (**green**)

LED 3 color	Status
Solid green	Camera is powered (HIROSE or PoE)
LED off	No power

Table 42: Status LED3

Status LEDs Manta type B

The tables below describe the status LEDs of Manta type B cameras (G-223 / 235 / 282 / 283 / 419 / 505 / 609 / 917).

LED 1 color	Status
Solid orange	Ethernet link established
Flashing orange	Network traffic

Table 43: Status LED 1 (**orange**)

LED 2 color	Status
Solid green	Ethernet link established
Slow flashing green	Booting routine
Four rapid flashes per second	Transmission error. Contact support@alliedvision.com

Table 44: Status LED 2 (**green**)

Note _____ Manta type B cameras do not have a Power LED.



Video iris output description

Manta cameras provide built-in video type auto-iris controls.

Caution



Damage to the lens

The following schematic uses CAMERA POWER to power the video iris lens and assumes CAMERA POWER = 12 V. Most video iris lenses operate at a 8–16 V input voltage. Therefore, this circuit is not appropriate if using a 24 V camera power supply. Doing so may irreparably damage your lens. Please consult your video iris lens specifications for the appropriate drive voltage.

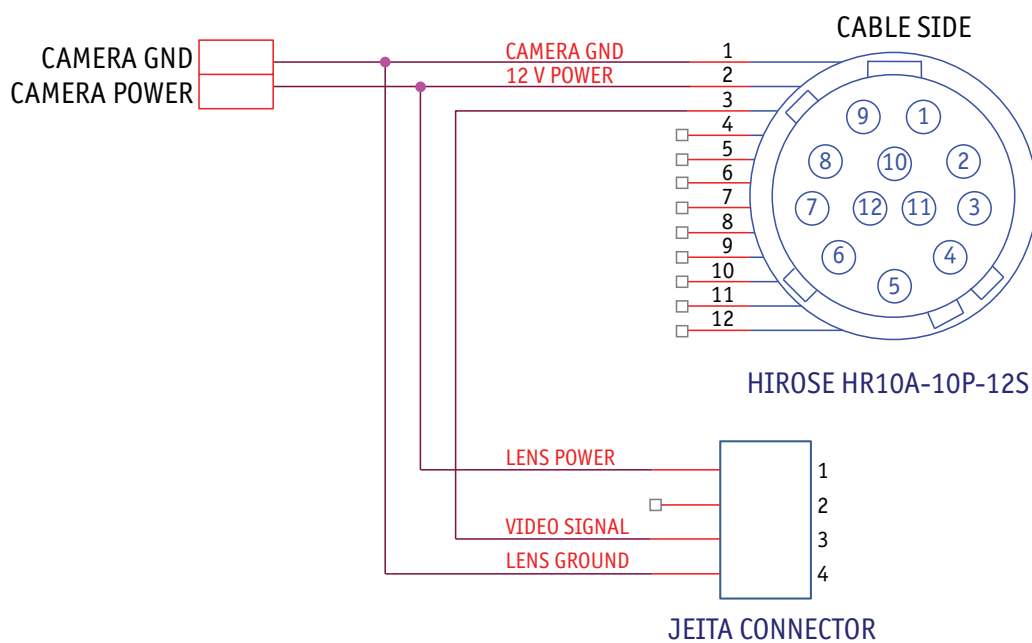

Figure 81: Manta video iris schematic

Control signals

The inputs and outputs of the camera can be configured by software. The different modes are described below.

Inputs

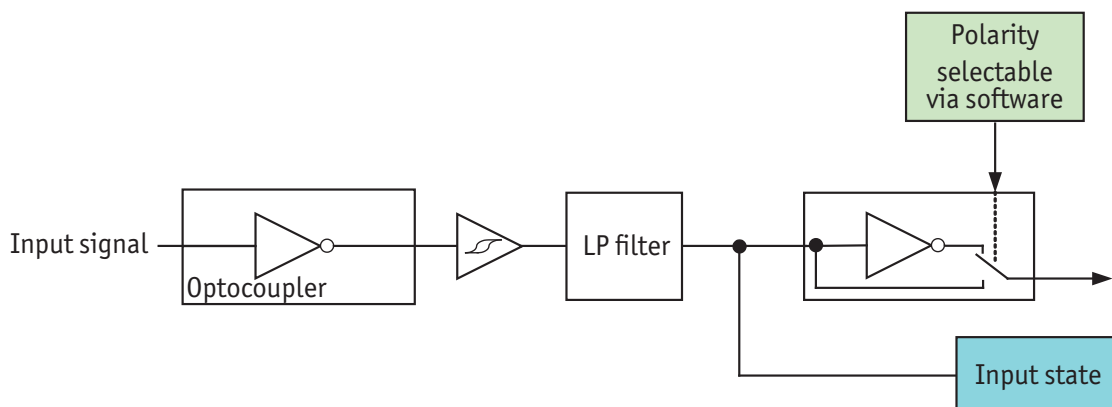

Figure 82: Input block diagram

Input/output pin control

All input and output signals running over the camera I/O connector are controlled by the I/O strobe commands. See [GigE Features Reference](#) document for more details.

Outputs

Output features are configured by software. Any signal can be placed on any output. The main features of output signals are described below:

Signal	Description
GPO	Configured to be a general purpose output, control of which is assigned to SyncOutGpoLevels
AcquisitionTriggerReady	Active once the camera has been recognized by the host PC and is ready to start acquisition
FrameTriggerReady	Active when the camera is in a state that will accept the next frame trigger
FrameTrigger	Active when an image has been initiated to start. This is a logic trigger internal to the camera, which is initiated by an external trigger or software trigger event
Exposing	Active for the duration of sensor exposure

Table 45: Output signals

Signal	Description
FrameReadout	Active at during frame readout, i.e. the transferring of image data from the CCD to camera memory
Imaging	High when the camera image sensor is either exposing and/or reading out data
Acquiring	Active during an acquisition stream
SyncIn1	Active when there is an external trigger at SyncIn1
SyncIn2	Active when there is an external trigger at SyncIn2
Strobe1	The output signal is controlled according to Strobe1 settings

Table 45: Output signals

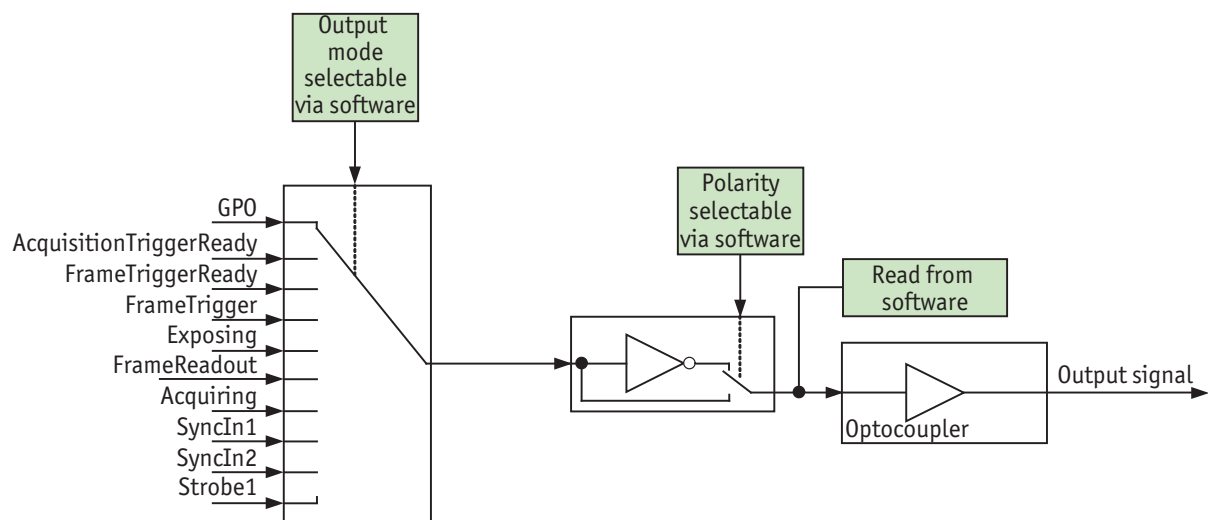

Figure 83: Output block diagram

Trigger timing diagram

The following diagram explains the trigger concept in general.

Note For trigger description on camera control basis see [GigE Features Reference](#) document.

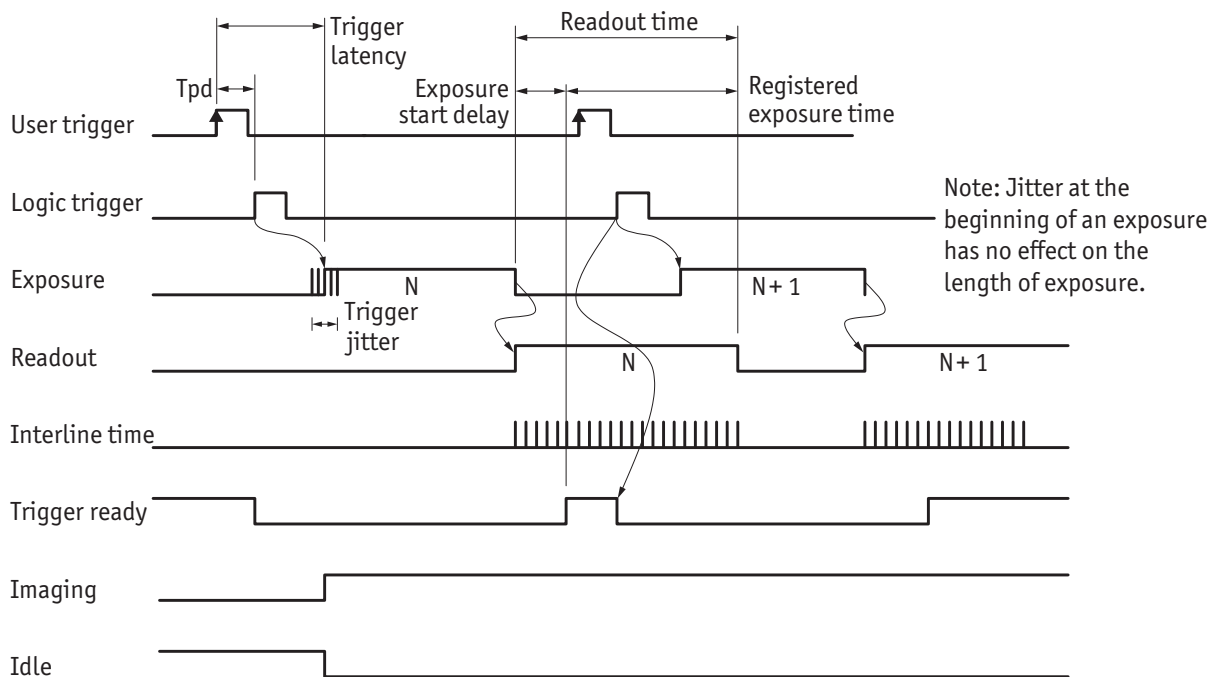

Figure 84: Trigger timing diagram

Notes on triggering

Trigger definitions

Term	Definition
User trigger	Trigger signal applied by the user (hardware trigger, software trigger)
Logic trigger	Trigger signal seen by the camera internal logic (not visible to the user)
T_{pd}	Propagation delay between the User trigger and the Logic trigger

Table 46: Trigger definitions

Term	Definition
Exposure	High when the camera image sensor is integrating light.
Readout	High when the camera image sensor is reading out data.
Trigger latency	Time delay between the user trigger and the start of exposure
Trigger jitter	Error in the trigger latency time
Trigger ready	Indicates to the user that the camera will accept the next trigger.
Registered exposure time	Exposure time value currently stored in the camera memory.
Exposure start delay	Registered Exposure Time subtracted from the Readout time and indicates when the next exposure cycle can begin such that the exposure will end after the current Readout.
Interline time	Time between sensor row readout cycles.
Imaging	High when the camera image sensor is either exposing and/or reading out data.
Idle	High if the camera image sensor is not exposing and/or reading out data.

Table 46: Trigger definitions

Trigger rules

Note The **user trigger pulse width** should be at least three times the width of the trigger latency as indicated in [Specifications](#) on page 26.



- The **end of exposure** will always trigger the next Readout.
- The **end of exposure** must always end after the current Readout.
- The **start of exposure** must always correspond with the Interline Time if Readout is true.
- **Exposure start delay** equals the Readout time minus the Registered Exposure Time.

Triggering during the Idle State

For applications requiring the shortest possible trigger Latency and the smallest possible trigger jitter the User trigger signal should be applied when Imaging is false and Idle is true.

Triggering during the Readout State

For applications requiring the fastest triggering cycle time whereby the camera image sensor is exposing and reading out simultaneously, then the User trigger signal should be applied as soon as a valid trigger Ready is detected.

In this case, trigger Latency and trigger jitter can be up to 1 line time since exposure must always begin on an Interline boundary.

www



For a more detailed description of the trigger concept for **advanced users** and special scenarios, see:

http://www.alliedvision.com/fileadmin/content/documents/products/cameras/various/appnote/Triggering_concept.pdf

Camera data path

Camera block diagrams

The following diagrams illustrate the data flow and the bit resolution of image data. The individual blocks are described in more detail in the **GigE Features Reference** document.

Manta type A: monochrome cameras

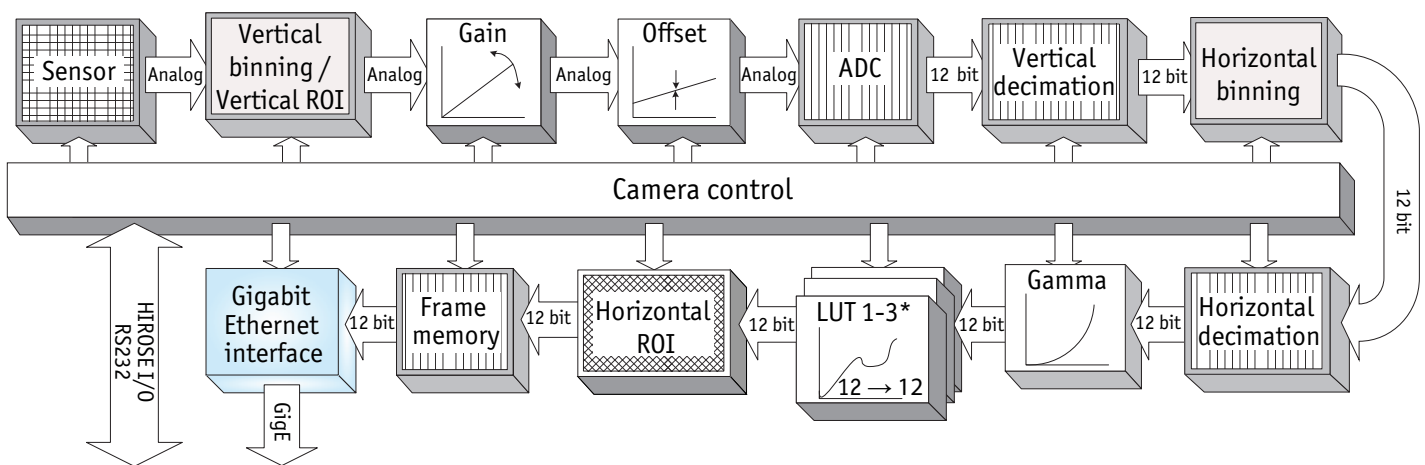

* If Gamma is enabled, only two LUTs are available.

Figure 85: Block diagram of Manta type A monochrome camera (Manta G-031 / 032 / 033 / 046 / 095 / 125 / 145 / 146 / 201 / 504)

Manta type A: color cameras

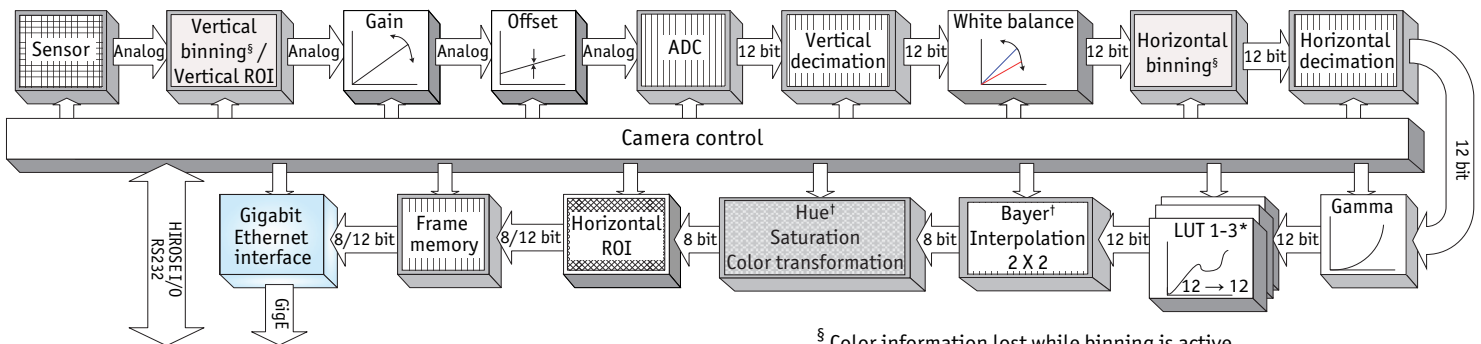

§ Color information lost while binning is active.

* If Gamma is enabled, only two LUTs are available.

† For on-camera interpolated *PixelFormats* only—outputs 8 bit. Raw un-interpolated *PixelFormats* skip this block—outputs 8/12 bit depending upon the bit depth of *PixelFormat* used.

Figure 86: Block diagram of Manta type A color camera (Manta G-031 / 032 / 033 / 046 / 095 / 125 / 145 / 146 / 201 / 504)

Manta type B: monochrome CCD cameras

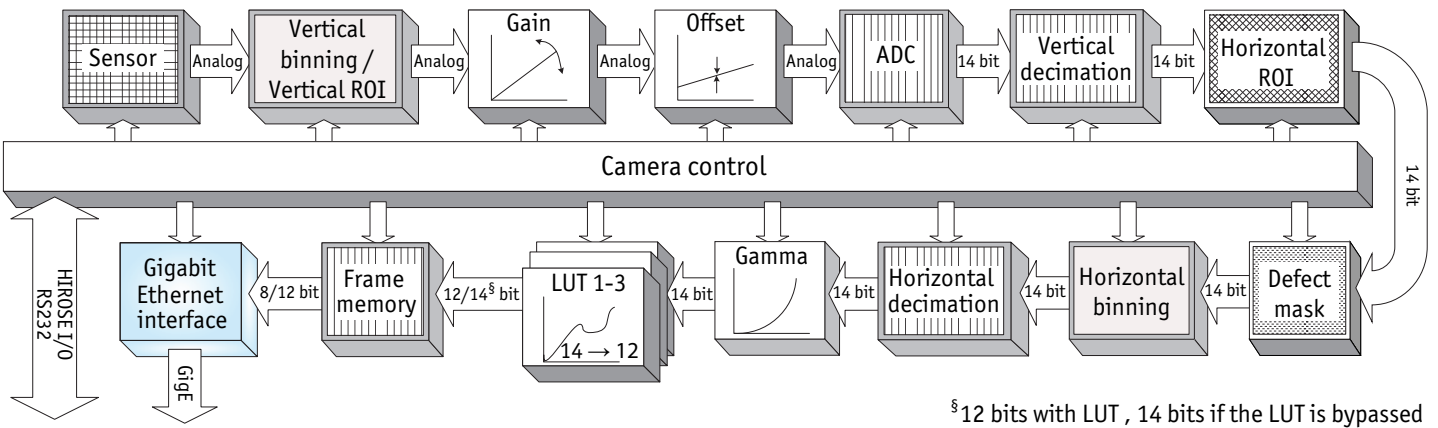

§ 12 bits with LUT , 14 bits if the LUT is bypassed

Figure 87: Block diagram of Manta type B monochrome camera (Manta G-282 / 283 / 505 / 609 / 917)

Manta type B: color CCD cameras

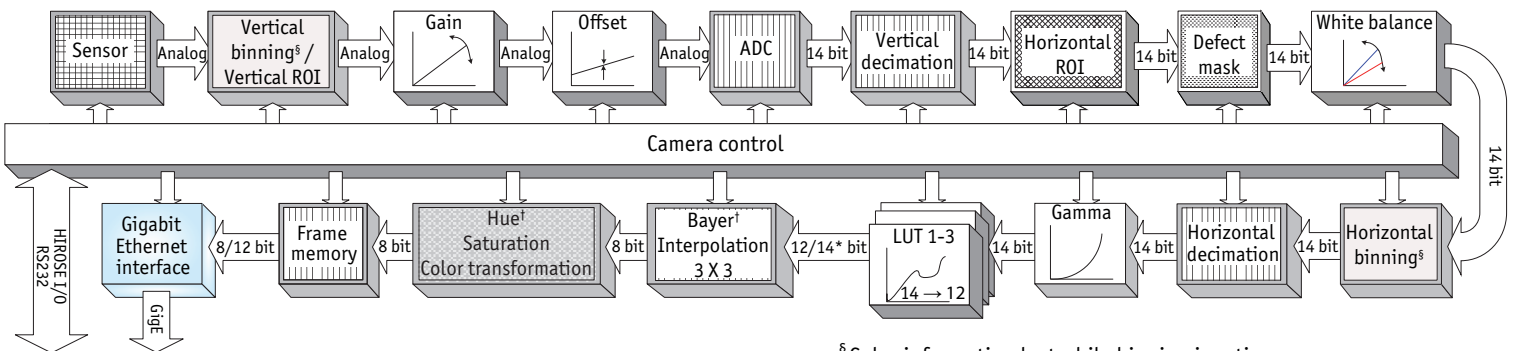

§ Color information lost while binning is active.

* 12 bits with LUT, 14 bits if the LUT is bypassed.

† For on-camera interpolated *PixelFormats* only—outputs 8 bit. Raw un-interpolated *PixelFormats* skip this block—outputs 8/12 bit, depending upon the bit depth of *PixelFormat* used.

Figure 88: Block diagram of Manta type B color camera (Manta G-282 / 283 / 505 / 609 / 917)

Manta type B: monochrome CMOS cameras

Manta G-223B / 223 NIR / 419B / 419 NIR

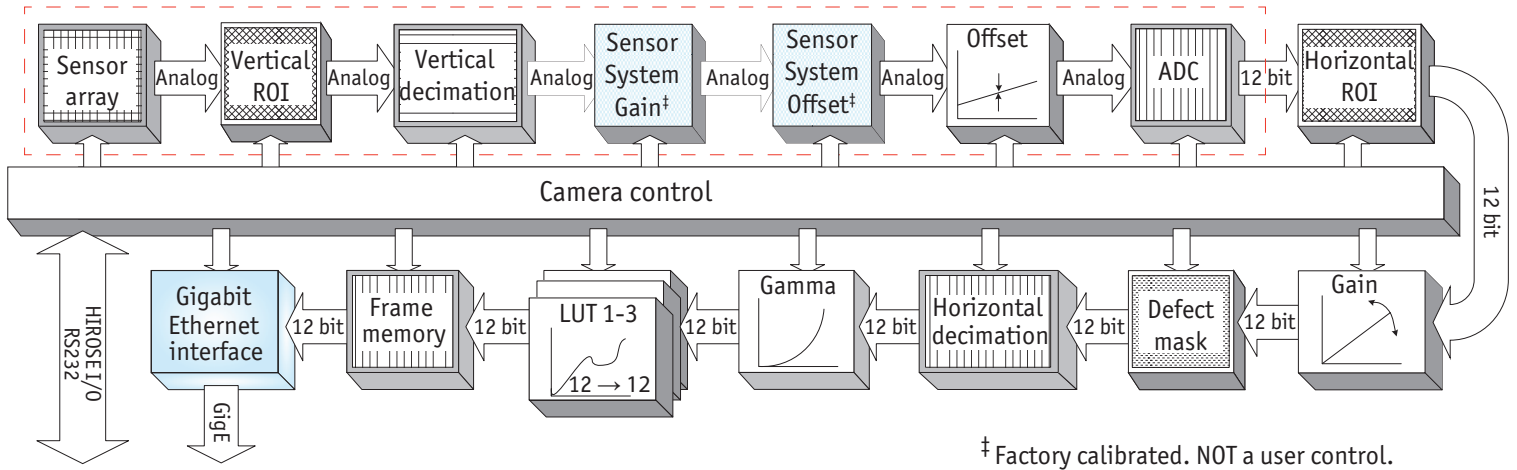

Figure 89: Block diagram of monochrome Manta G-223/ 223 NIR / 419 / 419 NIR cameras

Manta G-235B

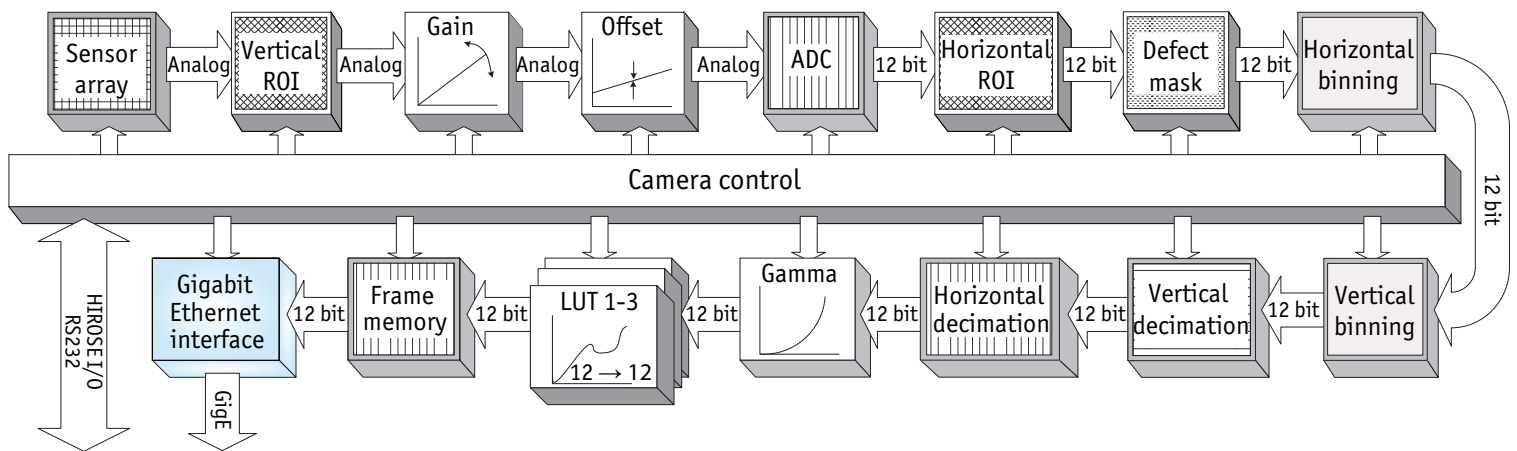

Figure 90: Block diagram of monochrome Manta G-235 camera

Manta type B: color CMOS cameras

Manta G-223C / 419C

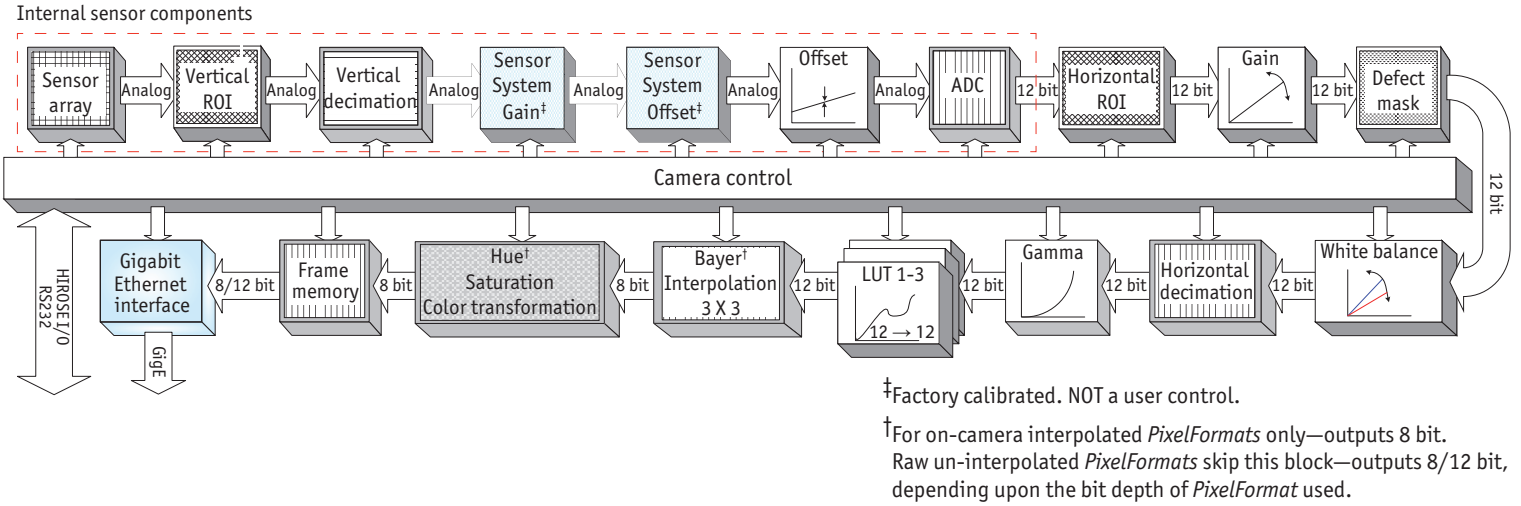

Figure 91: Block diagram of color Manta G-223/ 419 cameras

Manta G-235C

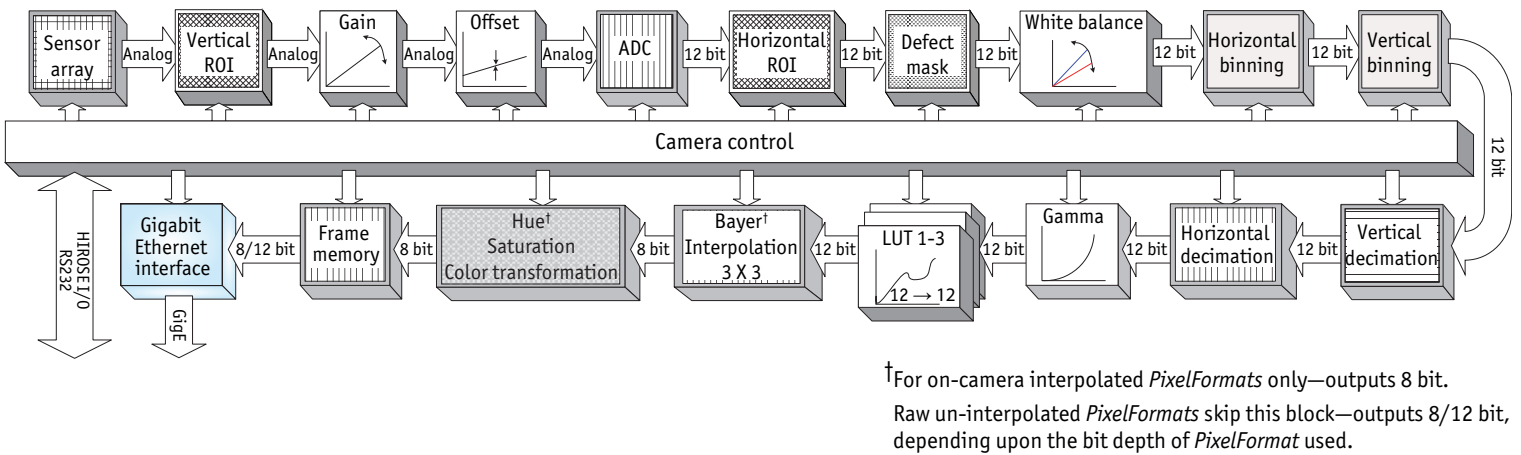

Figure 92: Block diagram of color Manta G-235 camera

Camera features

This chapter describes the Manta camera and driver features as displayed with the viewer of Allied Vision's VIMBA SDK.

www

For a detailed description of all GigE camera controls, refer to the **GigE Features Reference**:



http://www.alliedvision.com/fileadmin/content/documents/products/cameras/various/features/GigE_Features_Reference.pdf

Note

Manta type A cameras: G-031 / 032 / 033 / 046 / 095 / 125 / 145 / 146 / 201 / 504



Manta type B cameras: G-223 / 235 / 282 / 283 / 419 / 505 / 609 / 917

Hierarchy level 1	Hierarchy level 2	Hierarchy level 3	Hierarchy level 4
Acquisition			
	AcquisitionAbort		
	AcquisitionFrameCount		
	AcquisitionFrameRateAbs		
	AcquisitionFrameRateLimit		
	AcquisitionMode		
		Continous	
		SingleFrame	
		MultiFrame	
		Recorder	
	AcquisitionStart		
	AcquisitionStop		
	RecorderPreEventCount		
	Trigger		
		TriggerActivation	
			RisingEdge
			FallingEdge
			AnyEdge
			LevelHigh
			LevelLow
		TriggerDelayAbs	
		TriggerMode	
			On
			Off

Table 47: Manta camera features

Hierarchy level 1	Hierarchy level 2	Hierarchy level 3	Hierarchy level 4
		TriggerOverlap	
			Off
			PreviousFrame
		TriggerSelector	
			FrameStart
			AcquisitionStart
			AcquisitionEnd
			AcquisitionRecord
		TriggerSoftware	
		TriggerSource	
			Freerun
			Line1
			Line2
			FixedRate
			Software
BufferHandlingControl (Vimba v1.3 or higher)			
	StreamAnnounceBufferMinimum		
	StreamAnnouncedBufferCount		
	StreamBufferHandlingMode		
Controls			
	BlackLevelControl		
		BlackLevel	
		BlackLevelSelector	
	ColorTransformationControl		
		ColorTransformationMode	
			Off
			Manual
		ColorTransformationSelector	
			RBGtoRGB
		ColorTransformationValue	
		ColorTransformationValueSelector	
	DSPSubregion		
		DSPSubregionBottom	
		DSPSubregionLeft	
		DSPSubregionRight	
		DSPSubregionTop	
	EdgeFilter (only type A cameras)		
		Smooth2	
		Smooth1	
		Off	
		Sharpen1	

Table 47: Manta camera features

Hierarchy level 1	Hierarchy level 2	Hierarchy level 3	Hierarchy level 4
		Sharpen2	
	Exposure		
		ExposureAuto	
			Off
			Once
			Continuous
		ExposureAutoControl	
			ExposureAutoAdjustTol
			ExposureAutoAlg
			ExposureAutoMax
			ExposureAutoMin
			ExposureAutoOutliers
			ExposureAutoRate
			ExposureAutoTarget
		ExposureMode	
			Timed
			TriggerWidth
		ExposureTimeAbs	
		ExposureTimeIncrement	
	GainControl		
		Gain	
		GainAuto	
			Off
			Once
			Continuous
		GainAutoControl	
			GainAutoAdjustTol
			GainAutoMax
			GainAutoMin
			GainAutoOutliers
			GainAutoRate
			GainAutoTarget
		GainSelector	
	Gamma		
	Hue		
	Iris		
		IrisAutoTarget	
		IrisMode	
			Disabled
			Video
			VideoOpen
			VideoClose

Table 47: Manta camera features

Hierarchy level 1	Hierarchy level 2	Hierarchy level 3	Hierarchy level 4
		IrisVideoLevel	
		IrisVideoLevelMax	
		IrisVideoLevelMin	
	LUTControl		
		LUTEnable	
		LUTIndex	
		LUTInfo	
			LUTAddress
			LUTBitLengthIn
			LUTBitLengthOut
			LUTSize
		LUTLoad (only type A cameras, applicable to each single LUT)	
		LUTLoadAll (only type B cameras, applicable to all LUTs)	
		LUTMode	
			Luminance
			Red
			Green
			Blue
		LUTSave (only type A cameras, applicable to each single LUT)	
		LUTSaveAll (only type B cameras, applicable to all LUTs)	
		LUTSelector	
			LUT1
			LUT2
			LUT3
		LUTValue	
	NirMode (only G-145B NIR)		
		Off	
		On_HighQuality	
		On_Fast	
	Saturation		
	SubstrateVoltage		
		VsubValue	
	Whitebalance		
		BalanceRatioAbs	
		BalanceRatioSelector	
			Red
			Blue
		BalanceWhiteAuto	
			Off
			Once
			Continuous
		BalanceWhiteAutoControl	

Table 47: Manta camera features

Hierarchy level 1	Hierarchy level 2	Hierarchy level 3	Hierarchy level 4
			BalanceWhiteAutoAdjustTol
			BalanceWhiteAutoRate
DeviceStatus (only type B cameras)			
	DeviceTemperature		
	DeviceTemperatureSelector		
EventControl			
	EventData		
		EventAcquisitionEndFrameID	
		EventAcquisitionEndTimestamp	
		EventAcquisitionRecordTriggerFrameID	
		EventAcquisitionRecordTriggerTimestamp	
		EventAcquisitionStartFrameID	
		EventAcquisitionStartTimestamp	
		EventErrorFrameID	
		EventErrorTimestamp	
		EventExposureEndFrameID	
		EventExposureEndTimestamp	
		EventFrameTriggerFrameID	
		EventFrameTriggerReadyFrameID	
		EventFrameTriggerReadyTimestamp	
		EventFrameTriggerTimestamp	
		EventLine1FallingEdgeFrameID	
		EventLine1FallingEdgeTimestamp	
		EventLine1RisingEdgeFrameID	
		EventLine1RisingEdgeTimestamp	
		EventLine2FallingEdgeFrameID	
		EventLine2FallingEdgeTimestamp	
		EventLine2RisingEdgeFrameID	
		EventLine2RisingEdgeTimestamp	
		EventLine3FallingEdgeFrameID	
		EventLine3FallingEdgeTimestamp	
		EventLine3RisingEdgeFrameID	
		EventLine3RisingEdgeTimestamp	
		EventLine4FallingEdgeFrameID	
		EventLine4FallingEdgeTimestamp	
		EventLine4RisingEdgeFrameID	
		EventLine4RisingEdgeTimestamp	
		EventOverflowFrameID	
		EventOverflowTimestamp	
		EventPtpSyncLockedFrameID (Ptp: only type B cameras)	
		EventPtpSyncLockedTimestamp	
		EventPtpSyncLostFrameID	

Table 47: Manta camera features

Hierarchy level 1	Hierarchy level 2	Hierarchy level 3	Hierarchy level 4
		EventPtpSyncLostTimestamp	
	EventID		
		EventAcquisitionEnd	
		EventAcquisitionRecordTrigger	
		EventAcquisitionStart	
		EventError	
		EventExposureEnd	
		EventFrameTrigger	
		EventFrameTriggerReady	
		EventLine1FallingEdge	
		EventLine1RisingEdge	
		EventLine2FallingEdge	
		EventLine2RisingEdge	
		EventLine3FallingEdge	
		EventLine3RisingEdge	
		EventLine4FallingEdge	
		EventLine4RisingEdge	
		EventOverflow	
		EventPtpSyncLocked (Ptp: only type B cameras)	
		EventPtpSyncLost	
	EventNotification		
		Off	
		On	
	EventSelector		
		AcquisitionStart	
		AcquisitionEnd	
		FrameTrigger	
		ExposureEnd	
		AcquisitionRecordTrigger	
		PtpSyncLost (Ptp: only type B cameras)	
		PtpSyncLocked	
		Line1RisingEdge	
		Line1FallingEdge	
		Line2RisingEdge	
		Line2FallingEdge	
		Line3RisingEdge	
		Line3FallingEdge	
		Line4RisingEdge	
		Line4FallingEdge	
		FrameTriggerReady	
	EventsEnable1		
GigE			

Table 47: Manta camera features

Hierarchy level 1	Hierarchy level 2	Hierarchy level 3	Hierarchy level 4
	BandwidthCtrlMode		
		StreamBytesPerSecond	
		SCPD	
		Both	
	ChunkModeActive		
	Configuration		
		IP Configuration Mode	
	Current		
		Current Default Gateway	
		Current IP Address	
		Current Subnet Mask	
	GVCP		
		Command Retries	
		Command Timeout	
		Heartbeat Interval	
		HeartbeatTimeout	
	GevSCPSPacketSize		
	NonImagePayloadSize		
	Ptp (only type B cameras)		
		PtpAcquisitionGateTime	
		PtpMode	
		PtpStatus	
	PayloadSize		
	Persistent		
		Persistent Default Gateway	
		Persistent IP Address	
		Persistent Subnet Mask	
	StreamBytesPerSecond		
	StreamFrameRateConstrain		
	StreamHold		
		StreamHoldCapacity	
		StreamHoldEnable	
			Off
			On
	Timestamp		
		GevTimestampControlLatch	
		GevTimestampControlReset	
		GevTimestampTickFrequency	
		GevTimestampValue	
I0			
	Strobe		
		StrobeDelay	

Table 47: Manta camera features

Hierarchy level 1	Hierarchy level 2	Hierarchy level 3	Hierarchy level 4
		StrobeDuration	
		StrobeDurationMode	
			Source
			Controlled
		StrobeSource	
			AcquisitionTriggerReady
			FrameTriggerReady
			FrameTrigger
			Exposing
			FrameReadout
			Acquiring
			LineIn1
			LineIn2
	SyncIn		
		SyncInGlitchFilter	
		SyncInLevels	
		SyncInSelector	
			SyncIn1
			SyncIn2
	SyncOut		
		SyncOutLevels	
		SyncOutPolarity	
			Normal
			Invert
		SyncOutSelector	
			SyncOut1
			SyncOut2
		SyncOutSource	
			GPO
			AcquisitionTriggerReady
			FrameTriggerReady
			Exposing
			FrameReadout
			Imaging
			Acquiring
			LineIn1
			LineIn2
			Strobe1
ImageFormat			
	Height		
	HeightMax		
	ImageSize		

Table 47: Manta camera features

Hierarchy level 1	Hierarchy level 2	Hierarchy level 3	Hierarchy level 4
	OffsetX		
	OffsetY		
	PixelFormat		
	Width		
	WidthMax		
ImageMode			
	BinningHorizontal		
	BinningVertical		
	DecimationHorizontal (not G-031 / G-032)		
	DecimationVertical (not G-031 / G-032)		
	ReverseX		
	ReverseY		
	SensorHeight		
	SensorWidth		
Info			
	Device MAC Address		
	DeviceFirmwareVersion		
	DeviceID		
	DeviceModelName		
	DevicePartNumber		
	DeviceScanType		
	DeviceVendorName		
	FirmwareVerBuild		
	FirmwareVerMajor		
	FirmwareVerMinor		
	SensorBits		
	SensorType		
SavedUserSets			
	UserSetDefaultSelector		
		Default	
		UserSet1	
		UserSet2	
		UserSet3	
	UserSetLoad		
	UserSetSave		
	UserSetSelector		
		Default	
		UserSet1	
		UserSet2	
		UserSet3	
Stream			
	Info		

Table 47: Manta camera features

Hierarchy level 1	Hierarchy level 2	Hierarchy level 3	Hierarchy level 4
		GSVP Filter Version	
	Multicast		
		MulticastEnable	
		Multicast IP Address	
	Settings		
		GSVP Adjust Packet Size	
		GSVP Burst Size	
		GSVP Driver Selector	
		GSVP Host Receive Buffers	
		GSVP Max Look Back	
		GSVP Max Requests	
		GSVP Max Wait Size	
		GSVP Missing Size	
		GSVP Packet Size	
		GSVP Tilting Size	
		GSVP Timeout	
	Statistics		
		Stat Frame Rate	
		Stat Frames Delivered	
		Stat Frames Dropped	
		Stat Frames Rescued	
		Stat Frames Shoved	
		Stat Frames Underrun	
		Stat Local Rate	
		Stat Packets Errors	
		Stat Packets Missed	
		Stat Packets Received	
		Stat Packets Requested	
		Stat Packets Resent	
		Stat Time Elapsed	
StreamInformation (Vimba v1.3 or higher)			
	StreamID		
	StreamType		

Table 47: Manta camera features

Frame memory

Normally, an image is captured and transported in consecutive steps. The image is taken, read out from the sensor, digitized and sent over the Gigabit Ethernet network.

Manta cameras are equipped with a RAM. Table 48 on page 126 shows how many frames can be stored by each model.

Note  The number of frames (*StreamHoldCapacity*) depends on resolution, pixel format, and GVSP packet size. Stated number of frames is typical for full resolution, Mono8/Bayer8, and a *GevSCPSPacketSize* = 8192 bytes per packet.

The memory operates according to the FIFO (first in, first out) principle. This makes addressing for individual images unnecessary.

Type A/type B	Model	Memory size	Pixel format/ resolution
Manta type A models	Manta G-031B/C	32 MB memory: 99 frames	Mono8/ full resolution
	Manta G-032B/C	32 MB memory: 99 frames	
	Manta G-033B/C	32 MB memory: 99 frames	
	Manta G-046B/C	32 MB memory: 70 frames	
	Manta G-095C	32 MB memory: 34 frames	
	Manta G-125B/C	32 MB memory: 25 frames	
	Manta G-145B/C	32 MB memory: 22 frames	
	Manta G-145B/C-30fps	32 MB memory: 22 frames	
	Manta G-145B NIR	32 MB memory: 22 frames	
	Manta G-146B/C	32 MB memory: 22 frames	
	Manta G-201B/C	32 MB memory: 16 frames	
	Manta G-201B/C-30fps	32 MB memory: 16 frames	
Manta type B models	Manta G-223B/C	128 MB memory: 59 frames	Mono8/ full resolution
	Manta G-235B/C	128 MB memory: 56 frames	
	Manta G-282B/C	128 MB memory: 47 frames	
	Manta G-283B/C	128 MB memory: 47 frames	
	Manta G-419B/C	128 MB memory: 31 frames	
	Manta G-505B/C	128 MB memory: 26 frames	
	Manta G-609B/C	128 MB memory: 21 frames	
	Manta G-917B/C	128 MB memory: 14 frames	

Table 48: Image memory size (typical; see note above)

Color interpolation (Bayer demosaicing)

The color sensors capture the color information via so-called primary color (R-G-B) filters placed over the individual pixels in a **Bayer mosaic** layout. An effective Bayer → RGB color interpolation already takes place in all Manta color version cameras.

In color interpolation a red, green or blue value is determined for each pixel. An Allied Vision proprietary Bayer demosaicing algorithm is used for this interpolation (2x2), optimized for both sharpness of contours as well as reduction of false edge coloring.

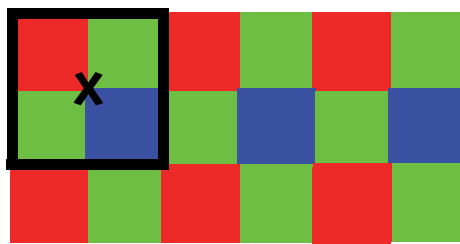

Figure 93: Bayer demosaicing (Manta type A: example of 2x2 matrix)



Figure 94: Bayer demosaicing (Manta type B: example of 3x3 matrix)

Color processing can be bypassed by using the RAW image transfer.

RAW mode is primarily used to

- save bandwidths on the Gigabit Ethernet network
- achieve higher frame rates
- use different Bayer demosaicing algorithms on the PC
 - for Manta the first pixel of the sensor is **RED**

Note



If the PC does not perform Bayer to RGB post-processing, the monochrome image will be superimposed with a checkerboard pattern.

In color interpolation a red, green or blue value is determined for each pixel (P1= first pixel; P2= second pixel; etc). Only two lines are needed for this interpolation:

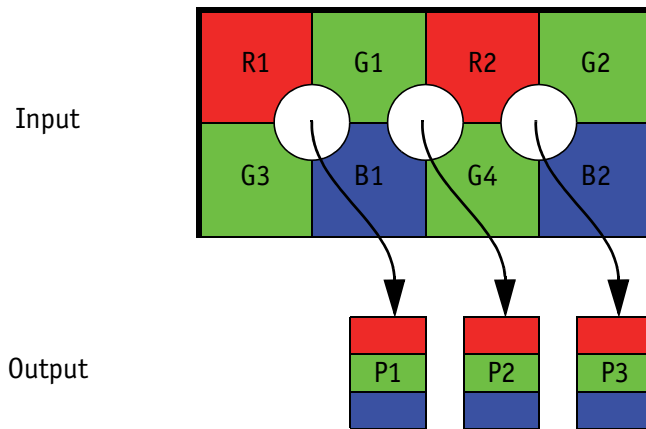

Figure 95: Bayer demosaicing (interpolation)

$$\begin{array}{lll}
 P1_{\text{red}} = R1 & P2_{\text{red}} = R2 & P3_{\text{red}} = R2 \\
 P1_{\text{green}} = \frac{G1 + G3}{2} & P2_{\text{green}} = \frac{G1 + G4}{2} & P3_{\text{green}} = \frac{G2 + G4}{2} \\
 P1_{\text{blue}} = B1 & P2_{\text{blue}} = B1 & P3_{\text{blue}} = B2
 \end{array}$$

Formula 1: Bayer demosaicing (type A cameras)

Note



- Please note that on the color camera, a wrongly colored border of one or two pixel wide forms on the left and right image borders. This is also a consequence of Bayer demosaicing as the image width displayed on the color camera is **not** scaled down.
- Using ROI, x and y resolutions must be even-numbered.

Resolution and ROI frame rates

This section charts the resulting frame rate from changing sensor height from full image to a single line.

Unless otherwise noted, sensors do not give an increase in readout speed with a reduction in width. However, in cases where a camera is limited by frame rate due to bandwidth restrictions, a reduction in width will give a frame rate increase. Cameras with a “burst mode” frame rate (see Chapter [Specifications](#) on page 26) are able to output more data than the maximum available bandwidth (124 MB/s), and will see a frame rate increase with a reduction in width.

Note



- Data was generated using **StreamBytesPerSecond = 124 MB/s** (full bandwidth) and an 8-bit pixel format. Frame rates may be lower if using network hardware incapable of 124 MB/s.
- For maximum speed advantage on quad-tap CCD sensors, **ROIs are center image**, where feature **OffsetY = (full sensor height – ROI height)/2**.
- There is no frame rate increase with reduced width.
- **BinningVertical** is horizontal row summing on CCD before readout. The frame rate for an ROI at the same effective height as binning will be slower because the CCD still needs to read out the “fast readout rows” in ROI mode.

Manta G-031B/C: ROI frame rates

$$\text{Max. frame rate of CCD} = \frac{1}{15.7\mu\text{s} \times \text{ROI height} + 2.53\mu\text{s} \times (492 - \text{ROI height}) + 252.74\mu\text{s}}$$

Formula 2: **Manta G-031**: theoretical maximum frame rate of CCD

Maximum frame rate at full resolution according formula: 125.2 fps

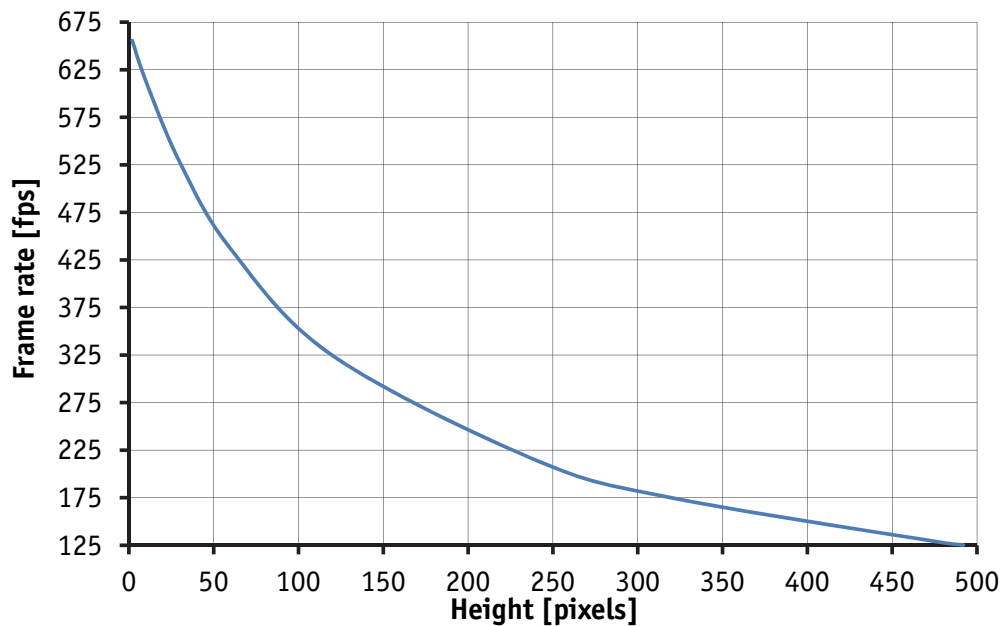

Table 49: Frame rates **Manta G-031** as function of ROI height[**width=656**]

ROI height	CCD*
492	125.2
480	127.7
320	174.8
240	214.4
120	324.5
60	436.7
30	527.9
10	613.2
2	655.6

Table 50: Frame rates (fps) of **Manta G-031** as function of ROI height (pixel) [**width=656**]

* CCD = theoretical maximum frame rate (in fps) of CCD according to given formula

Manta G-032B/C: ROI frame rates

$$\text{Max. frame rate of CCD} = \frac{1}{24.34\mu\text{s} \times \text{ROI height} + 3.01\mu\text{s} \times (492 - \text{ROI height}) + 495.50\mu\text{s}}$$

Formula 3: **Manta G-032**: theoretical maximum frame rate of CCD

Maximum frame rate at full resolution according formula: 80.7 fps

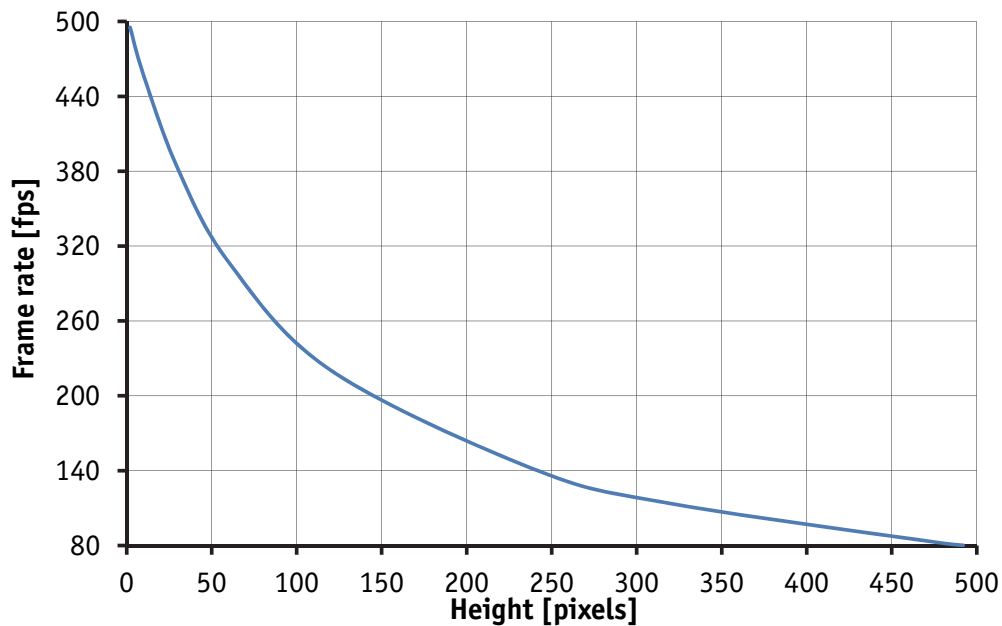

Table 51: Frame rates **Manta G-032** as function of ROI height[**width=656**]

ROI height	CCD*
492	80.1
480	81.8
320	113.6
240	140.9
120	220.4
60	307.1
30	382.2
10	456.6
2	495.2

Table 52: Frame rates (fps) of **Manta G-032** as function of ROI height (pixel) [**width=656**]

* CCD = theoretical maximum frame rate (in fps) of CCD according to given formula

Manta G-033B/C: ROI frame rates

$$\text{Max. frame rate of CCD} = \frac{1}{22.49\mu\text{s} \times \text{ROI height} + 1.51\mu\text{s} \times (492 - \text{ROI height}) + 198.4\mu\text{s}}$$

Formula 4: **Manta G-033**: theoretical maximum frame rate of CCD

Maximum frame rate at full resolution according formula: 88.7 fps

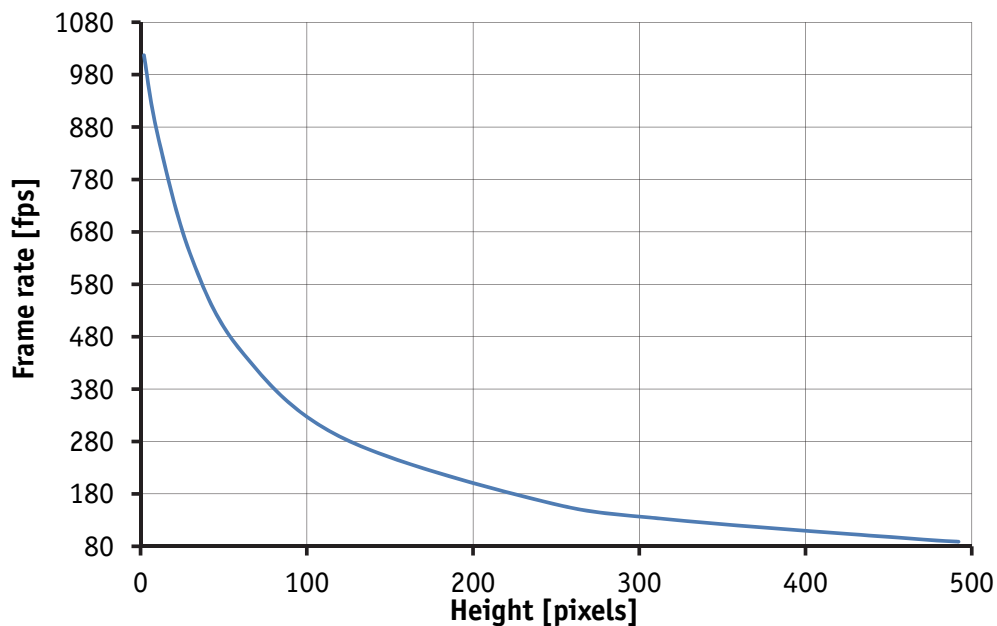

Table 53: Frame rates **Manta G-033** as function of ROI height[**width=656**]

ROI height	CCD*
492	88.7
480	90.8
320	130.6
240	167.3
120	289.1
60	454.5
30	636.6
10	868.7
2	1017.0

Table 54: Frame rates (fps) of **Manta G-033** as function of ROI height (pixel) [**width=656**]

* CCD = theoretical maximum frame rate (in fps) of CCD according to given formula

Manta G-046B/C: ROI frame rates

$$\text{Max. frame rate of CCD} = \frac{1}{25.14\mu\text{s} \times \text{ROI height} + 1.75\mu\text{s} \times (580 - \text{ROI height}) + 224.03\mu\text{s}}$$

Formula 5: **Manta G-046**: theoretical maximum frame rate of CCD

Maximum frame rate at full resolution according formula: 67.5 fps

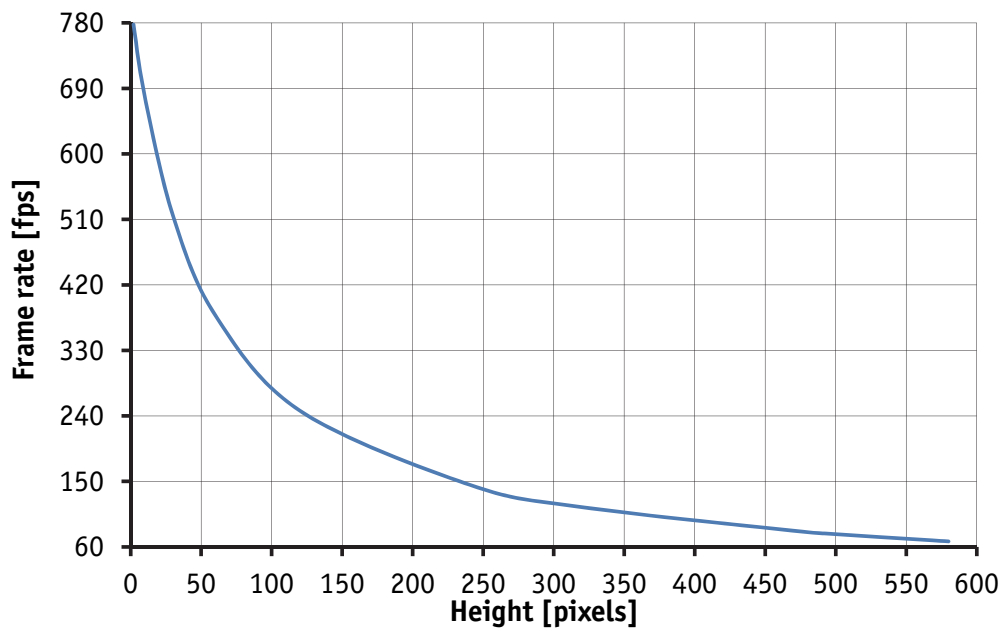

Table 55: Frame rates **Manta G-046** as function of ROI height[width=780]

ROI height	CCD*
580	67.5
492	78.4
480	80.2
320	114.6
240	145.6
120	247.1
60	378.4
30	515.2
10	678.9
2	777.7

Table 56: Frame rates (fps) of **Manta G-046** as function of ROI height (pixel) [width=780]

* CCD = theoretical maximum frame rate (in fps) of CCD according to given formula

Manta G-095B/C: ROI frame rates

$$\text{Max. frame rate of CCD} = \frac{1}{33.52\mu\text{s} \times \text{ROI height} + 4.87\mu\text{s} \times (734 - \text{ROI height}) + 327.80\mu\text{s}}$$

Formula 6: **Manta G-095**: theoretical maximum frame rate of CCD

Maximum frame rate at full resolution according formula: 40.1 fps

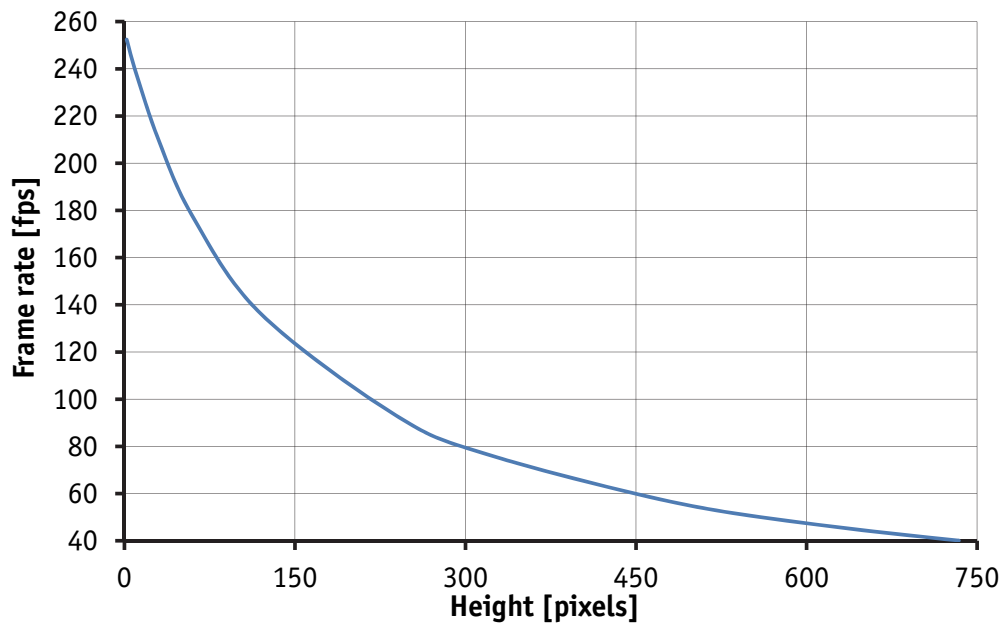

Table 57: Frame rates **Manta G-095** as function of ROI height[width=1292]

ROI height	CCD*
734	40.1
720	40.7
600	47.4
480	56.6
320	76.5
240	92.7
120	136.2
60	177.4
30	209.9
10	238.6
2	252.4

Table 58: Frame rates (fps) of **Manta G-095** as function of ROI height (pixel) [width=1292]

* CCD = theoretical maximum frame rate (in fps) of CCD according to given formula

Manta G-125B/C: ROI frame rates

$$\text{Max. frame rate of CCD} = \frac{1}{33.21\mu\text{s} \times \text{ROI height} + 5.04\mu\text{s} \times (964 - \text{ROI height}) + 226.52\mu\text{s}}$$

Formula 7: **Manta G-125**: theoretical maximum frame rate of CCD

Maximum frame rate at full resolution according formula: 31.0 fps

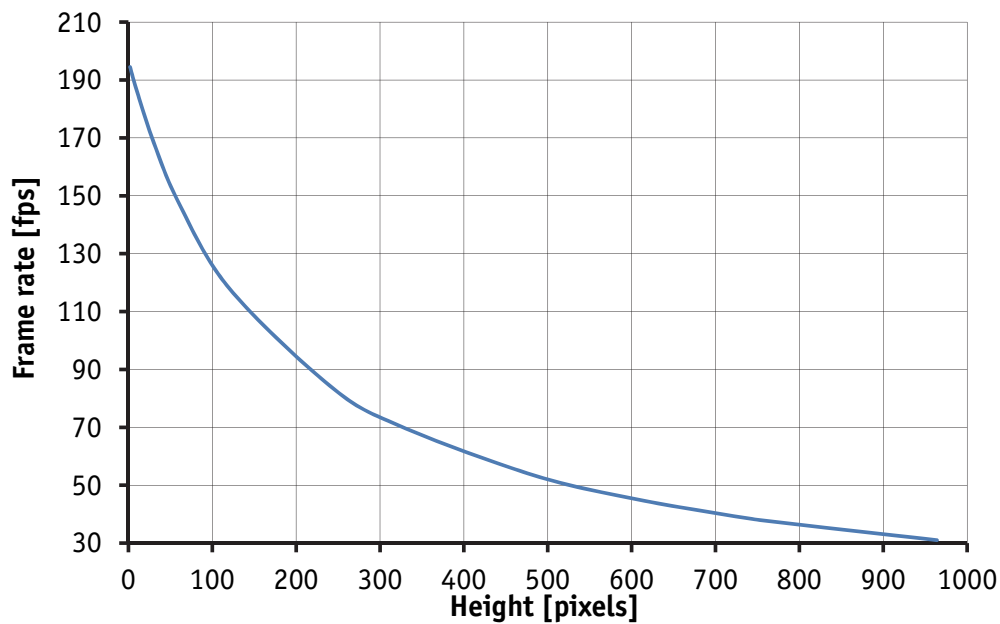

Table 59: Frame rates **Manta G-125** as function of ROI height[width=1292]

ROI height	CCD*
964	31.0
768	37.4
720	39.4
600	45.4
480	53.7
320	70.9
240	84.4
120	118.1
60	147.6
30	168.6
10	186.3
2	194.5

Table 60: Frame rates (fps) of **Manta G-125** as function of ROI height (pixel) [width=1292]

* CCD = theoretical maximum frame rate (in fps) of CCD according to given formula

Manta G-145B/C: ROI frame rates

$$\text{Max. frame rate of CCD} = \frac{1}{63.39\mu\text{s} \times \text{ROI height} + 5.86\mu\text{s} \times (1038 - \text{ROI height}) + 491.75\mu\text{s}}$$

Formula 8: **Manta G-145**: theoretical maximum frame rate of CCD

Maximum frame rate at full resolution according formula: 15.0 fps

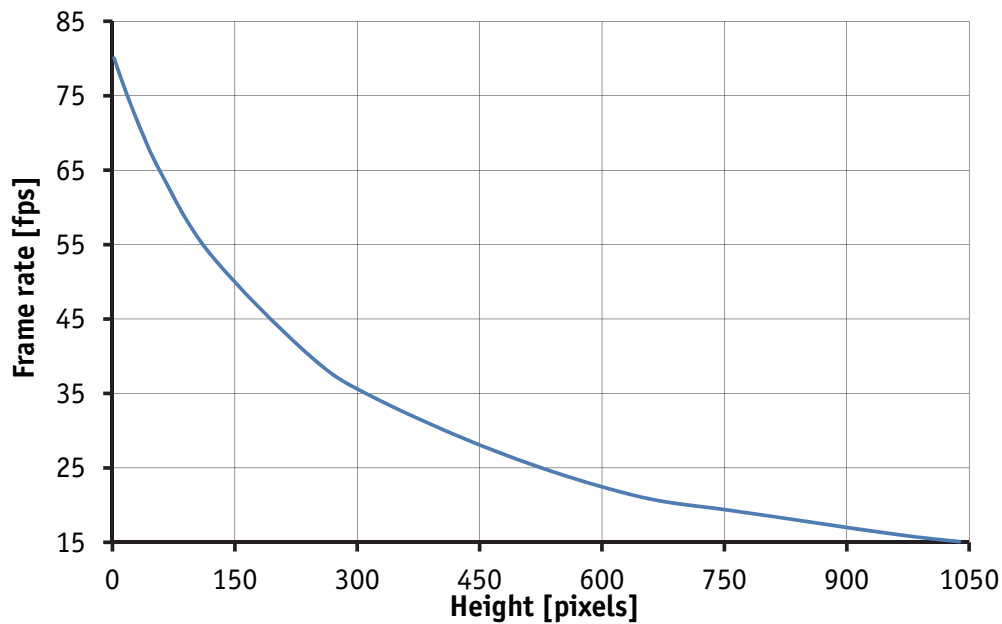

Table 61: Frame rates **Manta G-145** as function of ROI height[width=1388]

ROI height	CCD*
1038	15.0
960	16.0
768	19.1
640	21.2
480	26.8
320	34.4
240	40.2
120	53.7
60	64.5
30	71.7
10	77.4
2	80.0

Table 62: Frame rates (fps) of **Manta G-145** as function of ROI height (pixel) [width=1388]

* CCD = theoretical maximum frame rate (in fps) of CCD according to given formula

Manta G-145B/C-30fps: ROI frame rates

$$\text{Max. frame rate of CCD} = \frac{1}{31.7\mu\text{s} \times \text{ROI height} + 4.71\mu\text{s} \times (1038 - \text{ROI height}) + 245.88\mu\text{s}}$$

Formula 9: **Manta G-145-30fps**: theoretical maximum frame rate of CCD

Maximum frame rate at full resolution according formula: 30.1 fps

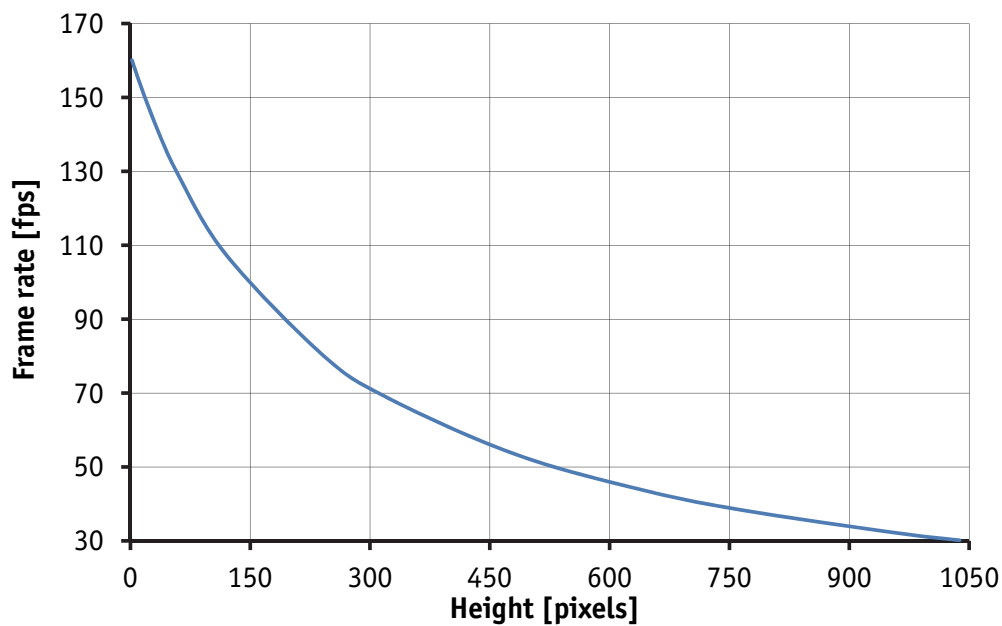

Table 63: Frame rates **Manta G-145-30fps** as function of ROI height[**width=1388**]

ROI height	CCD*
1038	30.1
960	32.1
768	38.2
640	43.8
480	53.5
320	68.9
240	80.4
120	107.4
60	129.0
30	143.4
10	154.9
2	160.1

Table 64: Frame rates (fps) of **Manta G-145-30fps** as function of ROI height (pixel) [**width=1388**]

* CCD = theoretical maximum frame rate (in fps) of CCD according to given formula

Manta G-145B NIR: ROI frame rates

$$\text{Max. frame rate of CCD} = \frac{1}{\text{MAX}(63.39\mu\text{s} \times \text{ROI height} + 11.46\mu\text{s} \times (1038 - \text{ROI height}) + 644\mu\text{s} + \text{MIN}(4300;\text{Expotime});\text{Expotime} + 142.86\mu\text{s})}$$

Formula 10: **Manta G-145B NIR**: theoretical maximum frame rate of CCD [NirMode=**Off/On_Fast**]

$$\text{Max. frame rate of CCD} = \frac{1}{63.39\mu\text{s} \times \text{ROI height} + 11.4 \mu\text{s} \times (1038 - \text{ROI height}) + (5653.89+\text{Expotime})\mu\text{s}}$$

Formula 11: **Manta G-145B NIR**: theoretical maximum frame rate of CCD [NirMode=**On_HighQuality**]

Maximum frame rate at full resolution according formula:

15.0 fps for NirMode=Off/On_Fast

13.9 fps for NirMode=On_HighQuality

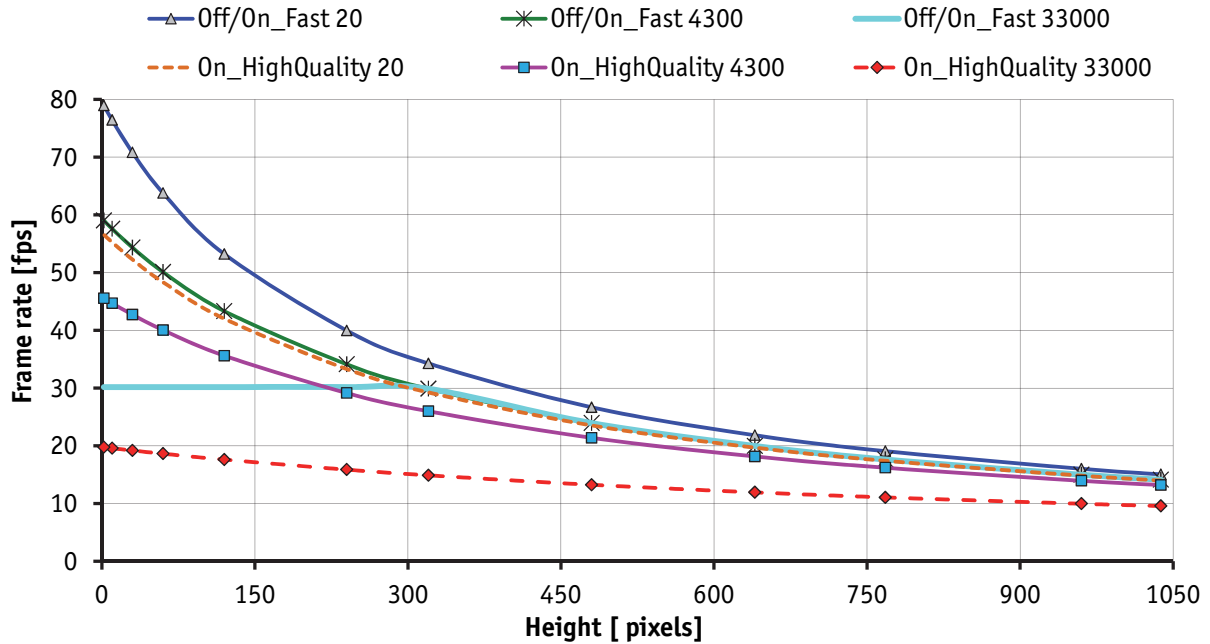

Formula 12: Frame rates* **Manta G-145B NIR** as function of ROI height[width=1388], NirMode and exposure time / μ s

* All values: CCD = theoretical maximum frame rate (in fps) of CCD according to given formula

NirMode	Off/On_Fast	Off/On_Fast	Off/On_Fast	On_HighQuality	On_HighQuality	On_HighQuality
Exp. time/ μ s	20	4300	33000	20	4300	33000
ROI height						
1038	15.0	14.1	14.1	13.9	13.2	9.5
960	16.0	14.9	14.9	14.8	13.9	9.9
768	19.0	17.6	17.6	17.4	16.2	11.0
640	21.8	19.9	19.9	19.6	18.1	11.9
480	26.6	23.9	23.9	23.5	21.3	13.2
320	34.2	29.8	29.8	29.2	25.9	14.8
240	39.9	34.1	30.1	33.2	29.1	15.8
120	53.2	43.3	30.1	42.0	35.6	17.6
60	63.7	50.1	30.1	48.3	40.0	18.6
30	70.8	54.3	30.1	52.2	42.7	19.1
10	76.4	57.5	30.1	55.2	44.7	19.5
2	78.9	59.0	30.1	56.5	45.5	19.7

Formula 13: Frame rates* (fps) of **Manta G-145B NIR** as function of ROI height (pixel) [width=1388], NirMode and exposure time / μ s

* All values: CCD = theoretical maximum frame rate (in fps) of CCD according to given formula

Manta G-146B/C: ROI frame rates

$$\text{Max. frame rate of CCD} = \frac{1}{53.54\mu\text{s} \times \text{ROI height} + 10.46\mu\text{s} \times (1038 - \text{ROI height}) + 352\mu\text{s}}$$

Formula 14: **Manta G-146**: theoretical maximum frame rate of CCD

Maximum frame rate at full resolution according formula: 17.8 fps

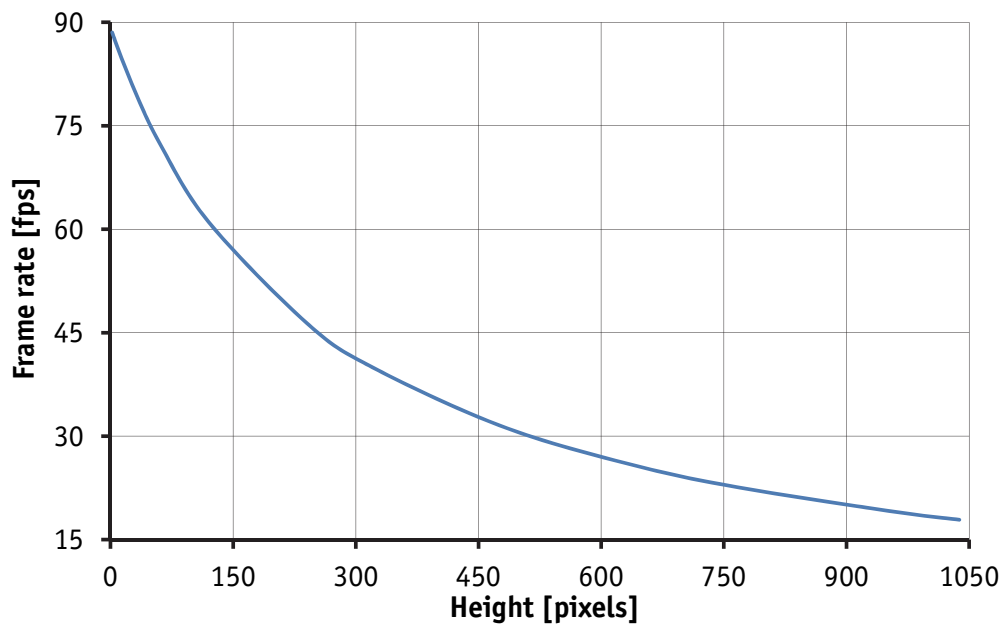

Table 65: Frame rates **Manta G-146** as function of ROI height[width=1388]

ROI height	CCD*
1038	17.8
960	19.0
768	22.5
640	25.7
480	31.3
320	40.0
240	46.4
120	61.0
60	72.4
30	79.9
10	85.9
2	88.5

Table 66: Frame rates (fps) of **Manta G-146** as function of ROI height (pixel) [width=1388]

* CCD = theoretical maximum frame rate (in fps) of CCD according to given formula

Manta G-201B/C: ROI frame rates

$$\text{Max. frame rate of CCD} = \frac{1}{54.81\mu\text{s} \times \text{ROI height} + 7.14\mu\text{s} \times (1234 - \text{ROI height}) + 340.03\mu\text{s}}$$

Formula 15: **Manta G-201**: theoretical maximum frame rate of CCD

Maximum frame rate at full resolution according formula: 14.7 fps

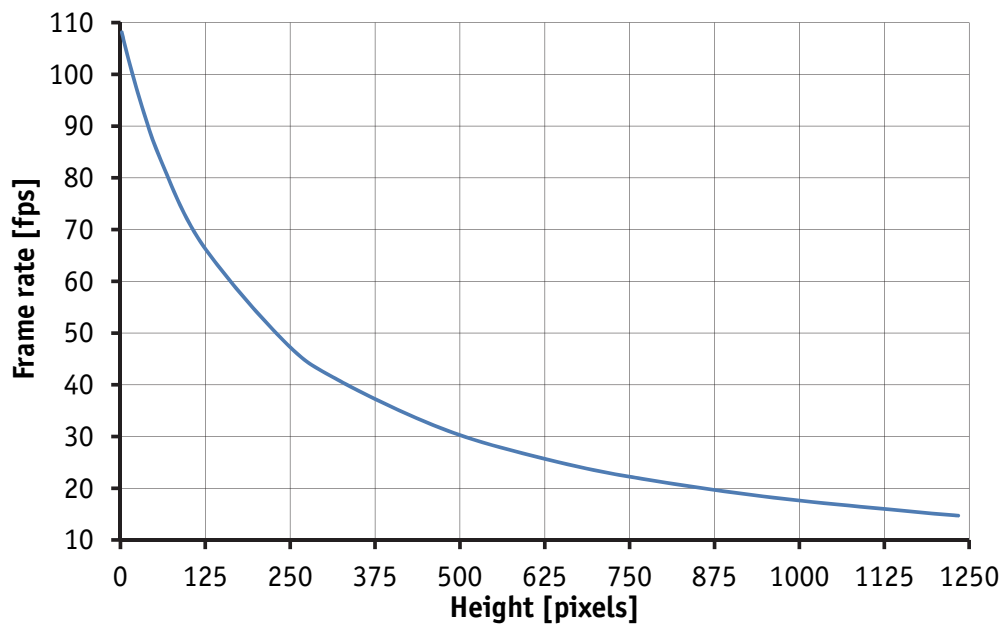

Table 67: Frame rates **Manta G-201** as function of ROI height[**width=1624**]

ROI height	CCD*
1234	14.7
1200	15.0
960	18.2
768	21.8
640	25.2
480	31.2
320	40.9
240	48.5
120	67.2
60	83.2
30	94.5
10	103.8
2	108.1

Table 68: Frame rates (fps) of **Manta G-201** as function of ROI height (pixel) [**width=1624**]

* CCD = theoretical maximum frame rate (in fps) of CCD according to given formula

Manta G-201B/C-30fps: ROI frame rates

$$\text{Max. frame rate of CCD} = \frac{1}{26.87\mu\text{s} \times \text{ROI height} + 2.84\mu\text{s} \times (1234 - \text{ROI height}) + 178.72\mu\text{s}}$$

Formula 16: **Manta G-201-30fps**: theoretical maximum frame rate of CCD

Maximum frame rate at full resolution according formula: 30.0 fps

Maximum frame rate at 1600 x 1200 (measured): 31.0 fps

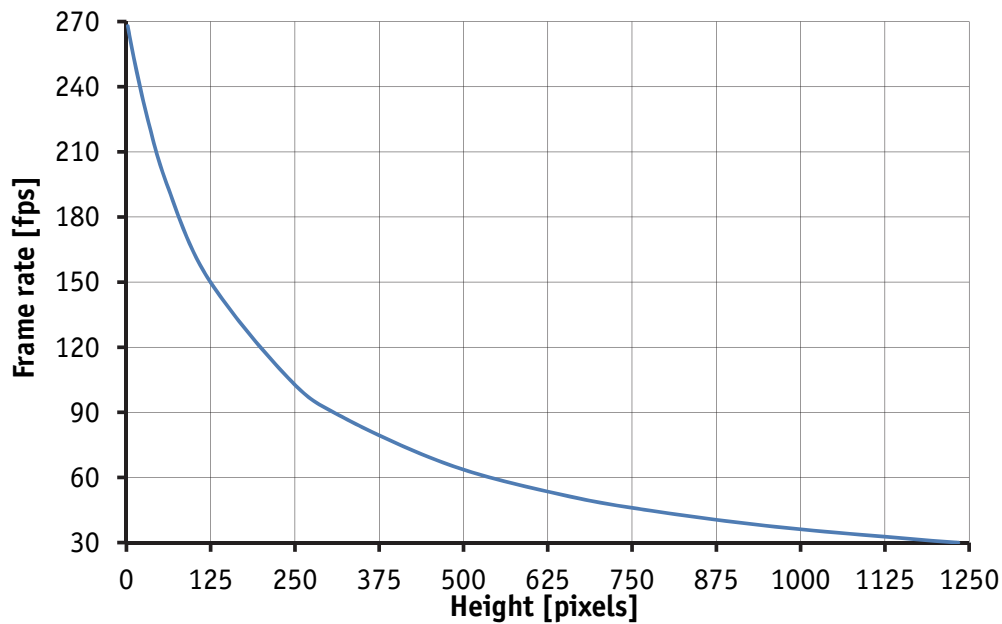

Table 69: Frame rates **Manta G-201-30fps** as function of ROI height[width=1624]

ROI height	CCD*
1234	30.0
1200	30.7
960	37.3
768	45.1
640	52.4
480	65.7
320	87.9
240	105.8
120	152.2
60	195.1
30	227.0
10	254.8
2	268.0

Table 70: Frame rates (fps) of **Manta G-201** as function of ROI height (pixel) [width=1624]

* CCD = theoretical maximum frame rate (in fps) of CCD according to given formula

Manta G-223B/C (NIR): ROI frame rates

Maximum frame rate at 1088 x 2048 (measured): 53.7 fps
(higher frame rates are possible with burst mode)

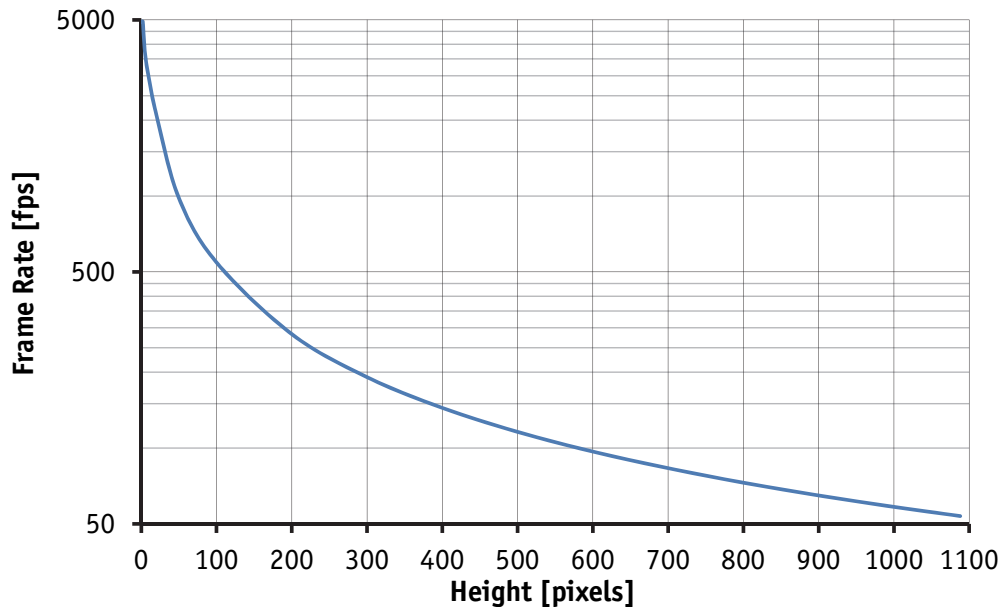

Table 71: Frame rates **Manta G-223** as function of ROI height [**width=2048**]

ROI height	Width*	fps
1088	2048	53.7
1000	2048	58.4
900	2048	64.8
800	2048	72.8
700	2048	83.1
600	2048	96.8
500	2048	115.9
400	2048	144.3
300	2048	191.1
200	2048	283.1
100	2048	545.2
50	2048	981.3
20	2048	2105.2
10	2048	2949.8
5	2048	3690.0
2	2048	4926.1
1	2048	4926.1

Table 72: Frame rates (fps) of **Manta G-223** as function of ROI height [**width=2048**]

*There will be an increase in frame rate with reduced width if the camera is bandwidth limited.

Manta G-235B/C: ROI frame rates

Maximum frame rate at 1936 x 1216 (measured): 50.7 fps
(higher frame rates are possible with burst mode)

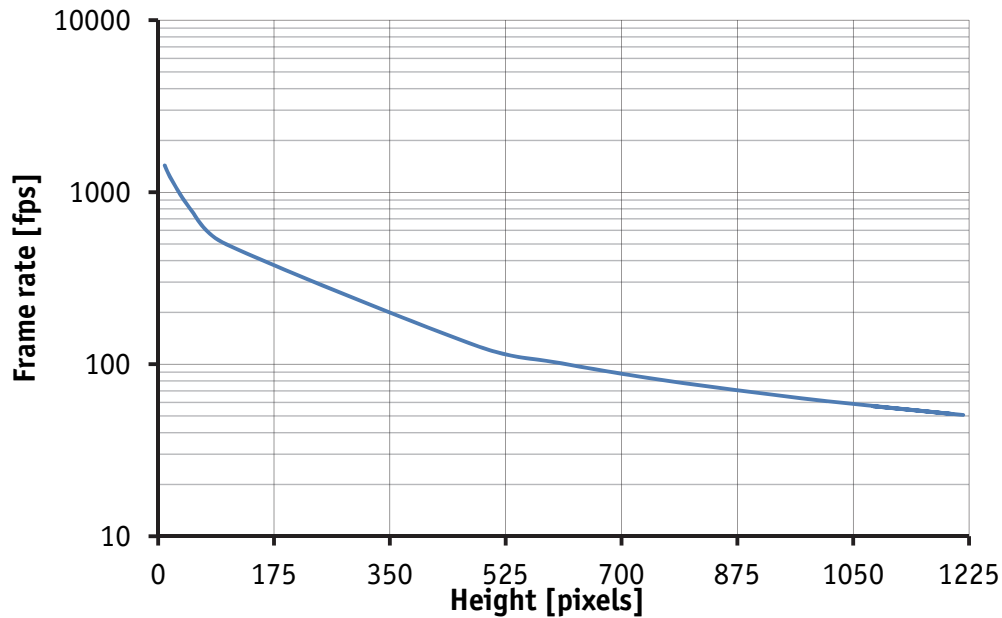

Table 73: Frame rates **Manta G-235** as function of ROI height [**width=1936[†]**]

ROI height	fps
1216	50.7
1200	51.3
1080	57.0
1024	60.2
960	64.2
768	80.2
600	102.7
480	128.4
100	504.5
50	787.9
20	1188.5
10	1431.1

Table 74: Frame rates (fps) of **Manta G-235** as function of ROI height [**width=1936^{*}**]

* There will be an increase in frame rate with reduced width if the camera is bandwidth limited.

Manta G-282B/C: ROI frame rates

$$\text{Max. frame rate of CCD} = \frac{1}{22.27\mu\text{s} \times \text{ROI height} + 4.36\mu\text{s} \times (1459 - \text{ROI height}) + 221.78\mu\text{s}}$$

Formula 17: **Manta G-282**: theoretical maximum frame rate of CCD

Maximum frame rate at full resolution according formula: 30.4 fps

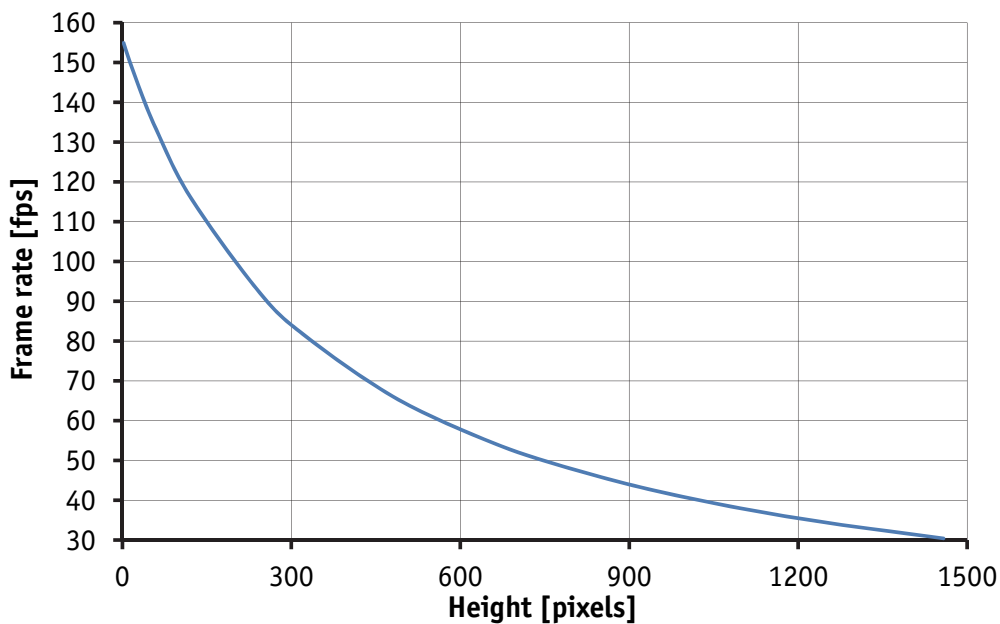

Table 75: Frame rates **Manta G-282** as function of ROI height[width=1458]

ROI height	CCD*
1458	30.4
1200	35.4
960	41.9
768	49.1
640	55.4
480	66.1
320	81.8
240	92.8
120	116.3
60	133.2
30	143.6
10	151.5
2	154.9

Table 76: Frame rates (fps) of **Manta G-282** as function of ROI height (pixel) [width=1458]

* CCD = theoretical maximum frame rate (in fps) of CCD according to given formula

Manta G-283B/C: ROI frame rates

$$\text{Max. frame rate of CCD} = \frac{1}{22.27\mu\text{s} \times \text{ROI height} + 4.36\mu\text{s} \times (1459 - \text{ROI height}) + 221.78\mu\text{s}}$$

Formula 18: **Manta G-283**: theoretical maximum frame rate of CCD

Maximum frame rate at full resolution according formula: 30.4 fps

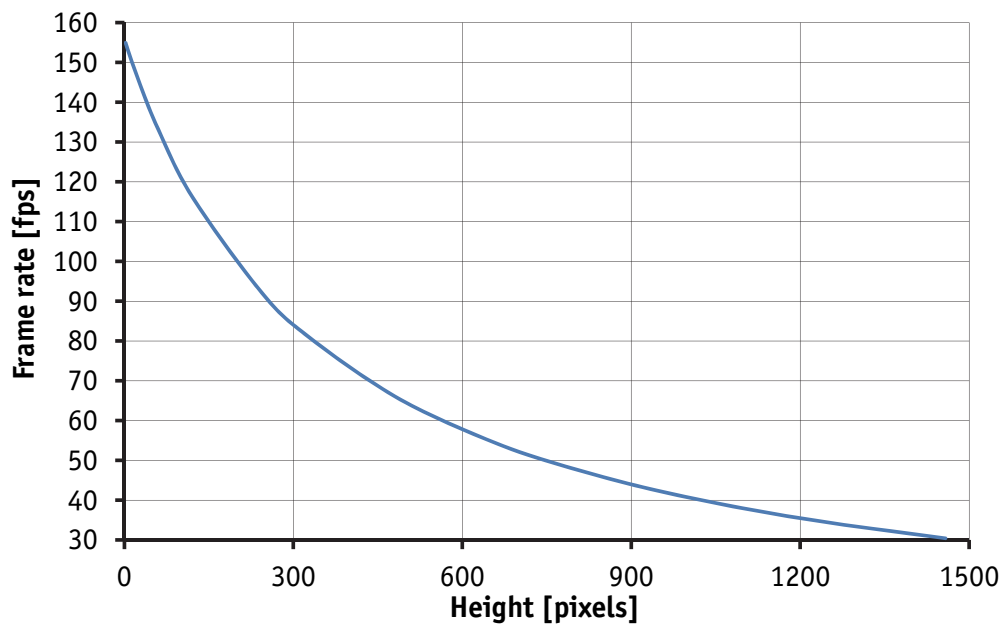

Table 77: Frame rates **Manta G-283** as function of ROI height[width=1458]

ROI height	CCD*
1458	30.4
1200	35.4
960	41.9
768	49.1
640	55.4
480	66.1
320	81.8
240	92.8
120	116.3
60	133.2
30	143.6
10	151.5
2	154.9

Table 78: Frame rates (fps) of **Manta G-283** as function of ROI height (pixel) [width=1458]

* CCD = theoretical maximum frame rate (in fps) of CCD according to given formula

Manta G-419B/C (NIR): ROI frame rates

Max. frame rate at 2048 x 2048 (measured): 28.6 fps (higher frame rates are possible with burst mode)

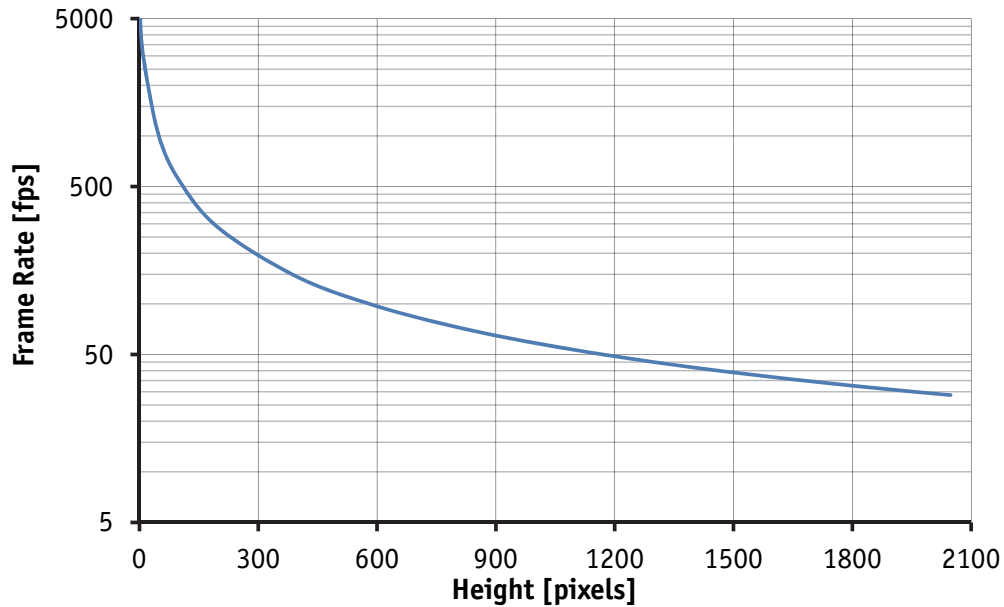

Table 79: Frame rates **Manta G-419 fps** as function of ROI height [**width=2048**]

ROI height	Width*	fps
2048	2048	28.6
2000	2048	29.3
1800	2048	32.5
1600	2048	36.6
1400	2048	41.8
1200	2048	48.7
1000	2048	58.4
900	2048	64.8
800	2048	72.8
700	2048	83.1
600	2048	96.8
500	2048	115.9
400	2048	144.3
300	2048	191.1
200	2048	283.1
100	2048	545.2
50	2048	981.3
20	2048	2105.2
10	2048	2949.8
5	2048	3690.0
2	2048	4926.1
1	2048	4926.1

Table 80: Frame rates (fps) of **Manta G-419** as function of ROI height [**width=2048**]

*There will be an increase in frame rate with reduced width if the camera is bandwidth limited.

Manta G-504B/C: ROI frame rates

$$\text{Max. frame rate of CCD} = \frac{1}{52.55\mu\text{s} \times \text{ROI height} + 10.27\mu\text{s} \times (2056 - \text{ROI height}) + 295.62\mu\text{s}}$$

Formula 19: **Manta G-504**: theoretical maximum frame rate of CCD

Maximum frame rate at full resolution according formula: 9.2 fps

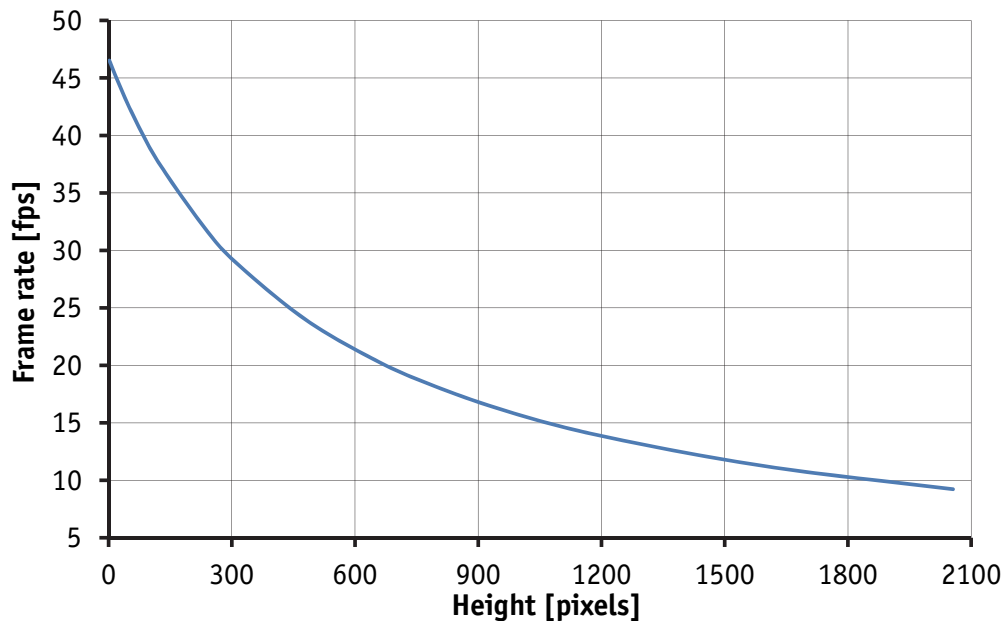

Table 81: Frame rates **Manta G-504** as function of ROI height[width=2452]

ROI height	CCD*
2056	9.2
1600	11.2
1200	13.8
960	16.1
768	18.5
640	20.6
480	23.9
320	28.6
240	31.6
120	37.7
60	41.7
30	44.0
10	45.8
2	46.5

Table 82: Frame rates (fps) of **Manta G-504** as function of ROI height (pixel) [width=2452]

* CCD = theoretical maximum frame rate (in fps) of CCD according to given formula

Manta G-505B/C: ROI frame rates

$$\text{Max. frame rate of CCD} = \frac{1}{32.18\mu\text{s} \times \text{ROI height} + 8.81\mu\text{s} \times (2056 - \text{ROI height}) + 321.82\mu\text{s}}$$

Formula 20: **Manta G-505**: theoretical maximum frame rate of CCD

Maximum frame rate at full resolution according formula: 15.0 fps

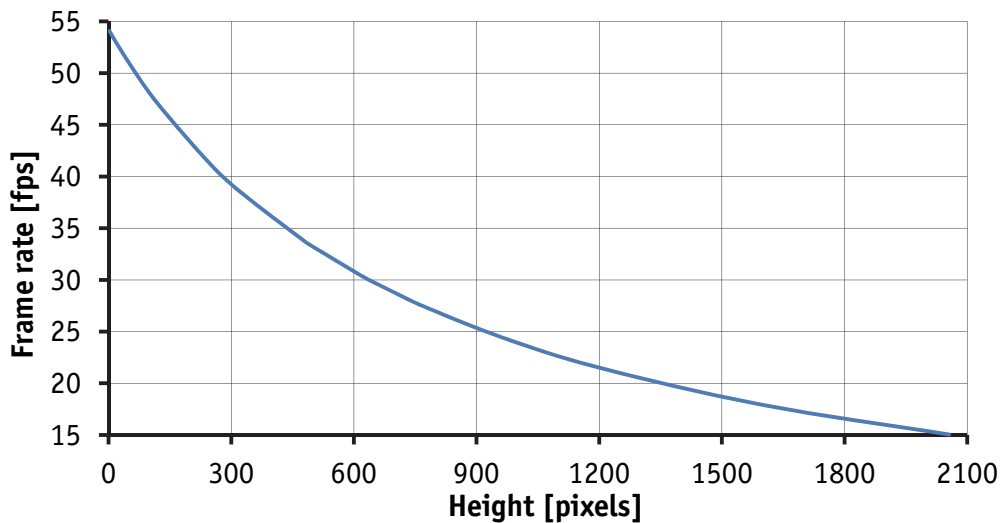

Table 83: Frame rates **Manta G-505** as function of ROI height[width=2452]

ROI height	CCD*
2056	15.0
1600	17.9
1200	21.5
960	24.5
768	27.5
734	28.1
640	29.9
614	30.5
492	33.4
480	33.7
320	38.6
240	41.6
120	47.1
60	50.4
30	52.2
10	53.5
2	54.1

Table 84: Frame rates (fps) of **Manta G-505** as function of ROI height (pixel) [width=2452]

* CCD = theoretical maximum frame rate (in fps) of CCD according to given formula

Manta G-609B/C: ROI frame rates

$$\text{Max. frame rate of CCD} = \frac{1}{29.71\mu\text{s} \times \text{ROI height} + 4.36\mu\text{s} \times (2207 - \text{ROI height}) + 229.22\mu\text{s}}$$

Formula 21: **Manta G-609**: theoretical maximum frame rate of CCD

Maximum frame rate at full resolution according formula: 15.2 fps

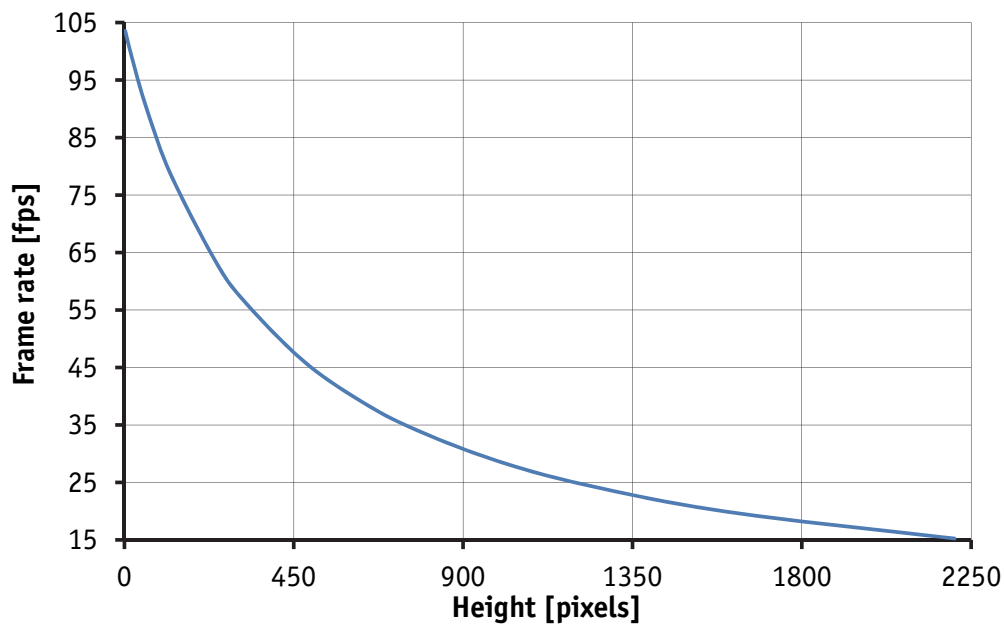

Table 85: Frame rates **Manta G-609** as function of ROI height[width=2206]

ROI height	CCD*
2206	15.2
1600	19.9
1200	24.9
960	29.4
768	34.3
640	38.6
480	45.8
320	56.4
240	63.7
120	79.0
60	89.8
30	96.4
10	101.4
2	103.5

Table 86: Frame rates (fps) of **Manta G-609** as function of ROI height (pixel) [width=2206]

* CCD = theoretical maximum frame rate (in fps) of CCD according to given formula

Manta G-917B/C: ROI frame rates

$$\text{Max. frame rate of CCD} = \frac{1}{29.71\mu\text{s} \times \text{ROI height} + 4.36\mu\text{s} \times (2207 - \text{ROI height}) + 229.22\mu\text{s}}$$

Formula 22: **Manta G-917**: theoretical maximum frame rate of CCD

Maximum frame rate at full resolution according formula: 10.1 fps

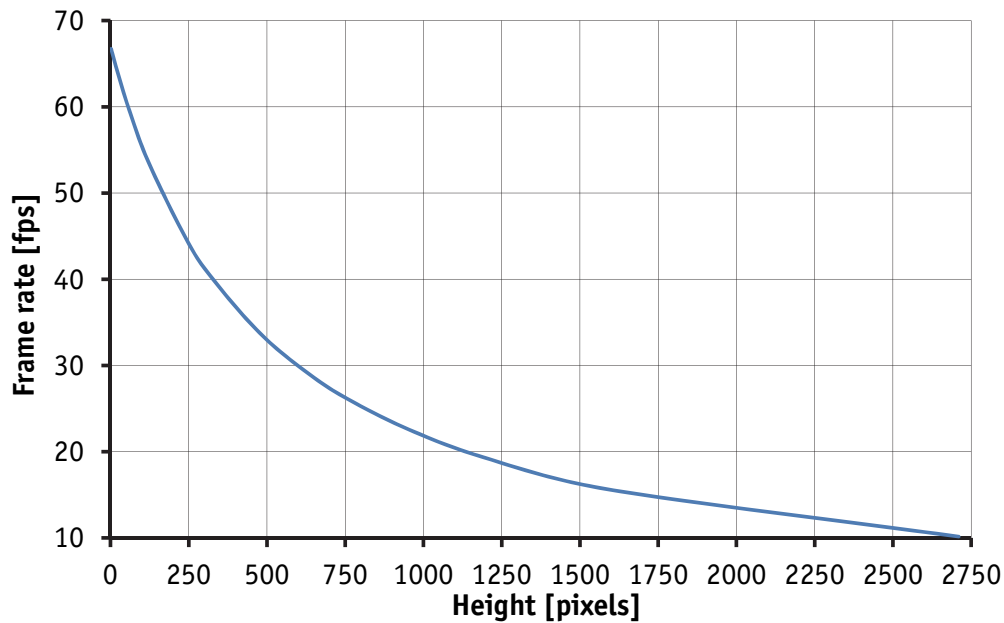

Table 87: Frame rates **Manta G-917** as function of ROI height[width=2710]

ROI height	CCD*
2710	10.1
1600	15.5
1200	19.2
960	22.4
768	25.9
640	28.8
480	33.6
320	40.3
240	44.8
120	53.6
60	59.6
30	63.0
10	65.6
2	66.7

Table 88: Frame rates (fps) of **Manta G-917** as function of ROI height (pixel) [width=2752]

* CCD = theoretical maximum frame rate (in fps) of CCD according to given formula

Appendix

Sensor position accuracy of Manta cameras

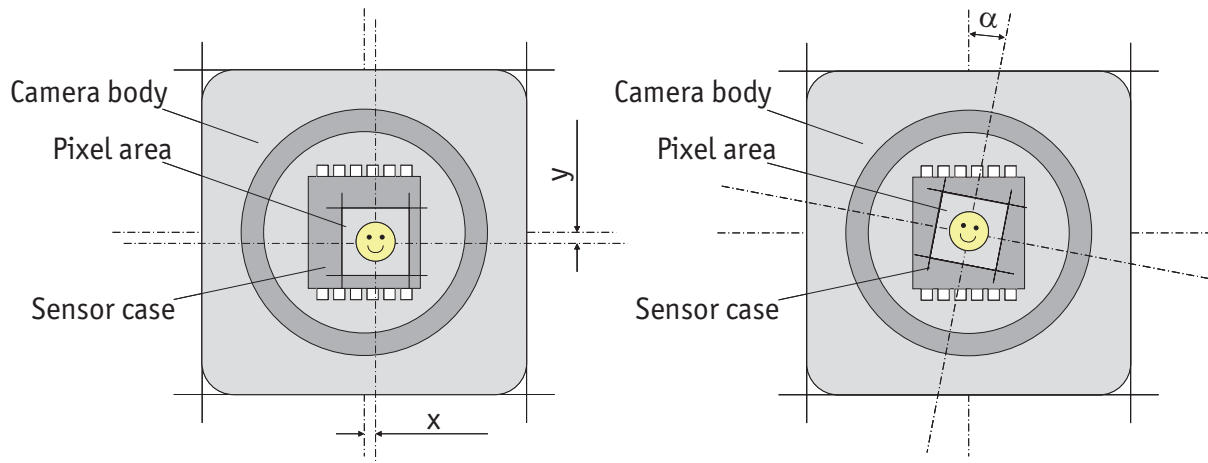

Figure 96: Allied Vision sensor position accuracy

Method of positioning

Optical alignment of the photo sensitive sensor area into the camera front module (lens mount front flange).

Reference points

Sensor: center of the pixel area (photo sensitive cells).

Camera: Center of the camera front flange (outer case edges).

Accuracy

x/y : $\pm 150 \mu\text{m}$ (sensor shift)

z : $+0 \mu\text{m}$ to $-150 \mu\text{m}$ (optical back focal length)

α : $\pm 0.5^\circ$ (sensor rotation)

Note

x/y - tolerances between the C-Mount hole and the pixel area may be higher.



Exceptions for non-PoE Manta cameras up to serial number 503323258

Manta standard housing

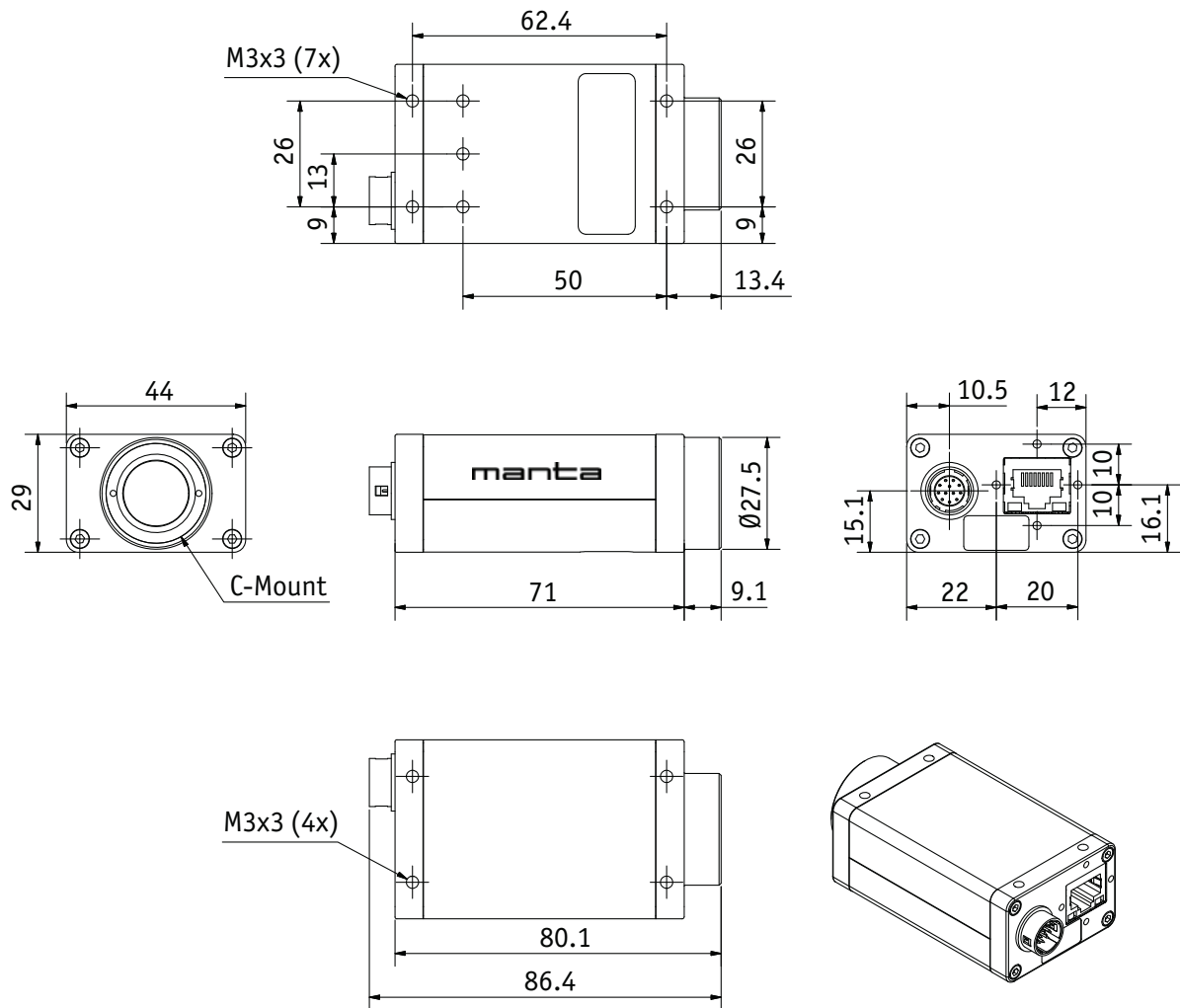

Figure 97: Camera dimensions for non-PoE Manta cameras up to serial number 503323258

Manta W90 housing

This version has the sensor tilted by 90 degrees clockwise, so that it views upwards.

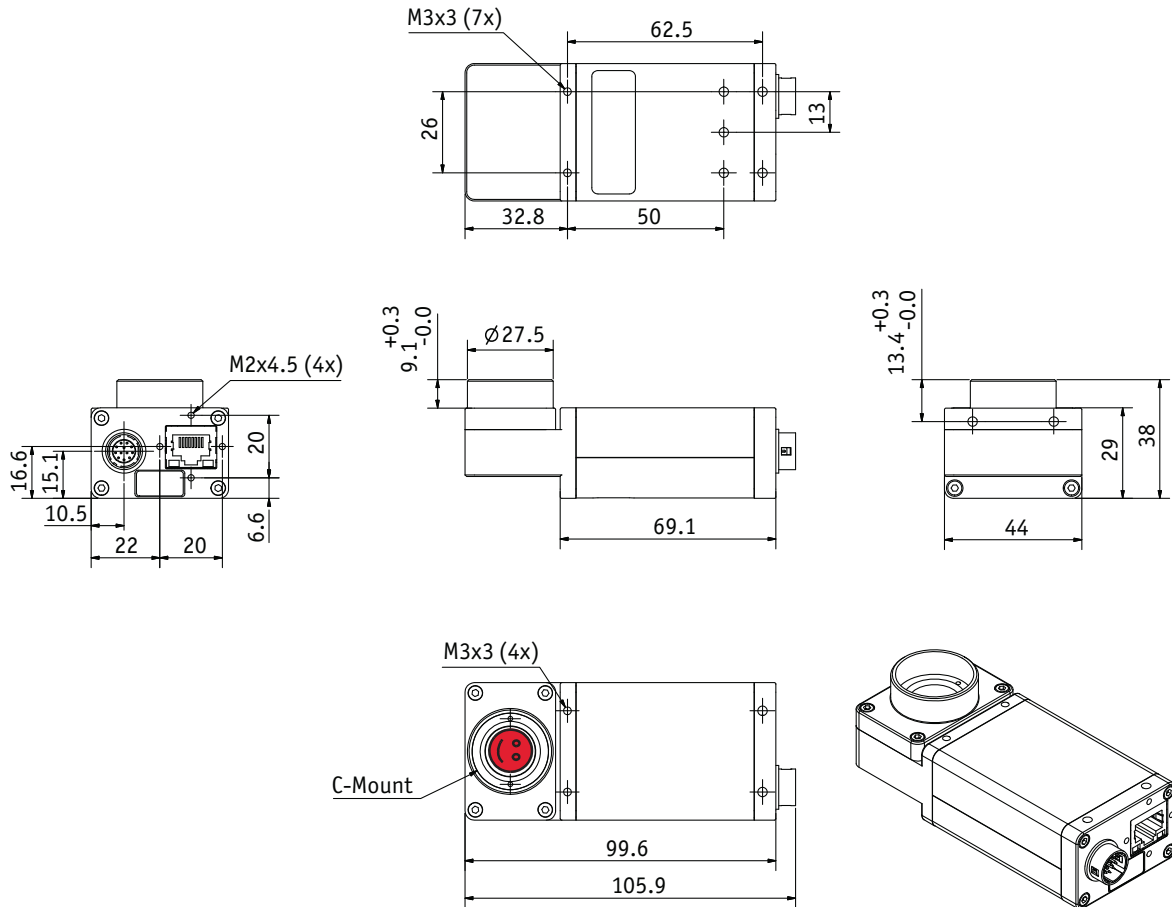

Figure 98: Camera dimensions for non-PoE **Manta W90** cameras up to serial number 503323258

Manta W90 S90 housing

This version has the sensor tilted by 90 degrees clockwise, so that it views upwards.

The sensor is also rotated by 90 degrees clockwise.

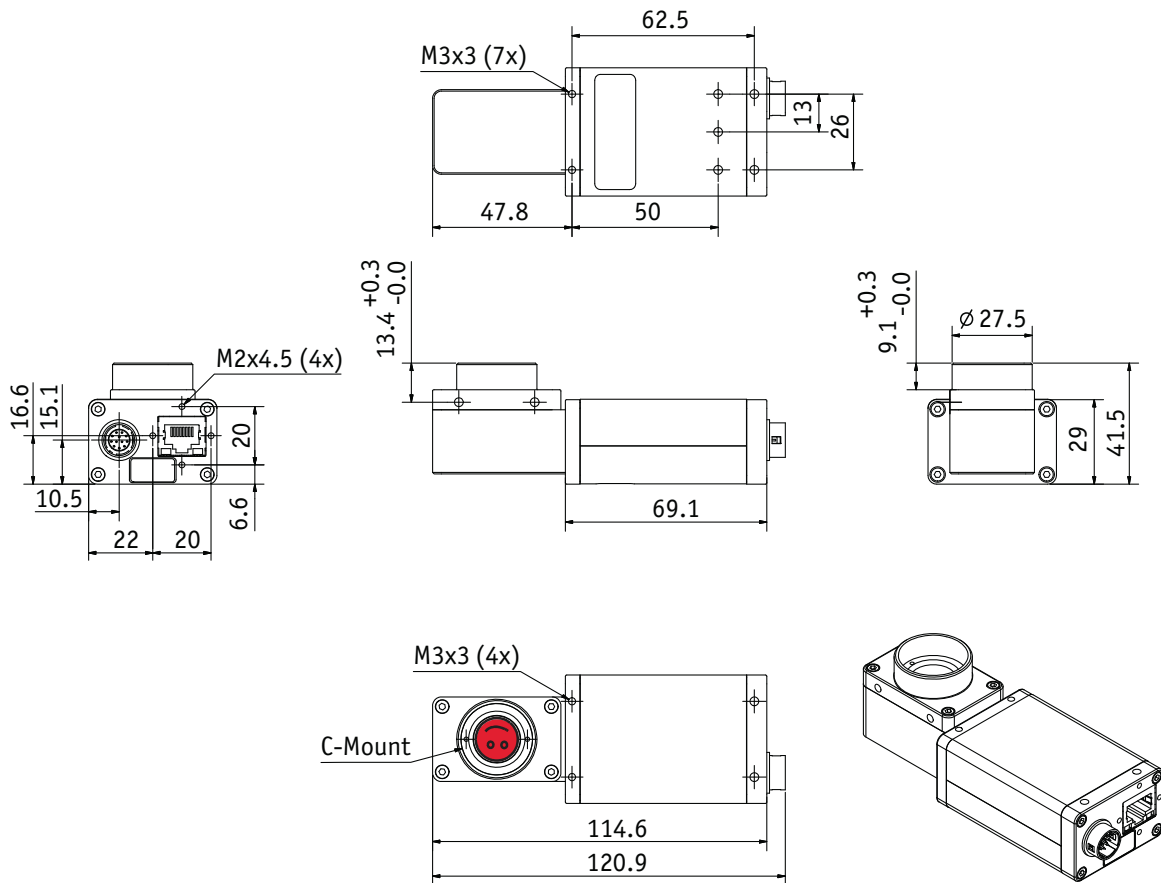

Figure 99: Camera dimensions for non-PoE **Manta W90 S90** cameras up to serial number 503323258

Manta W270 housing

This version has the sensor tilted by 270 degrees clockwise, so that it views downwards.

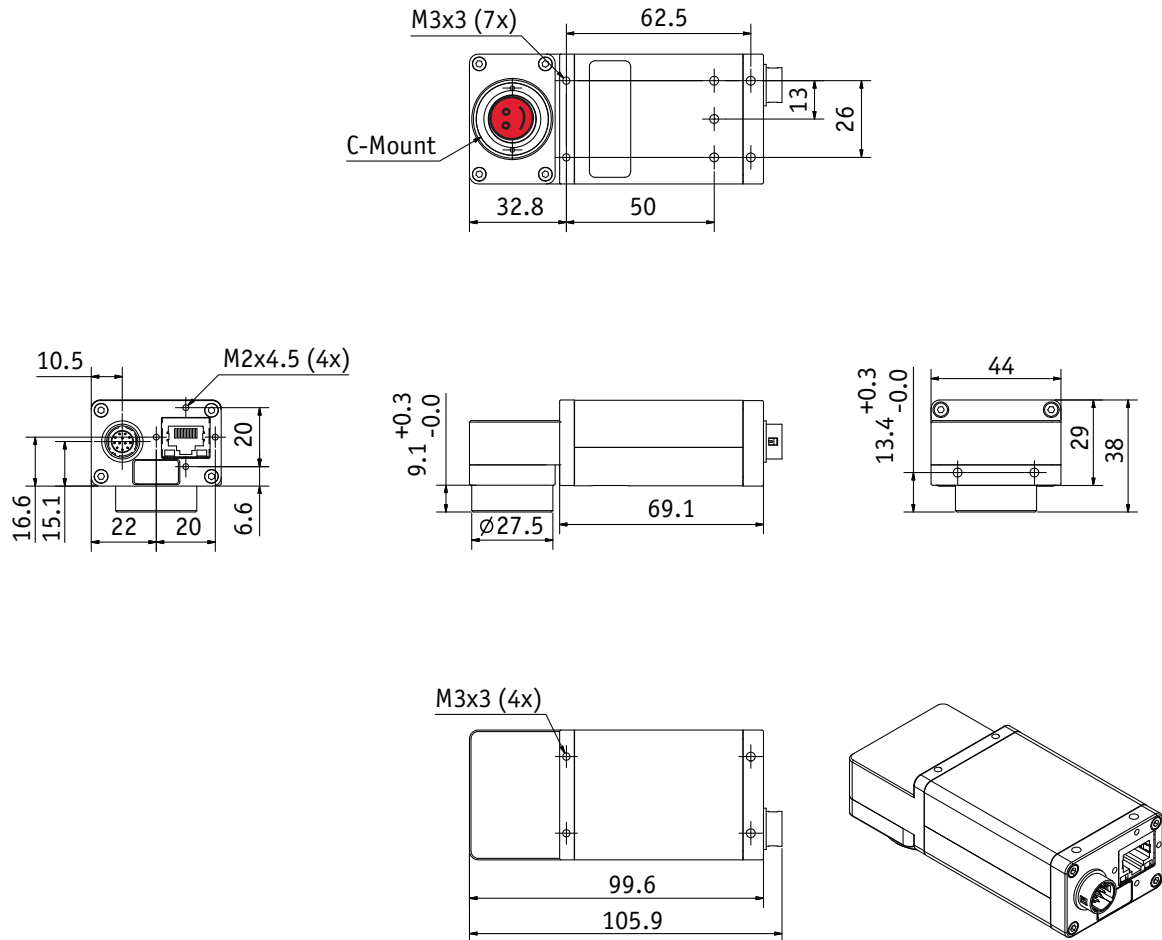

Figure 100: Camera dimensions for non-PoE **Manta W270** cameras up to serial number 503323258

Manta W270 S90 housing

This version has the sensor tilted by 270 degrees clockwise, so that it views downwards.

The sensor is also rotated by 90 degrees clockwise.

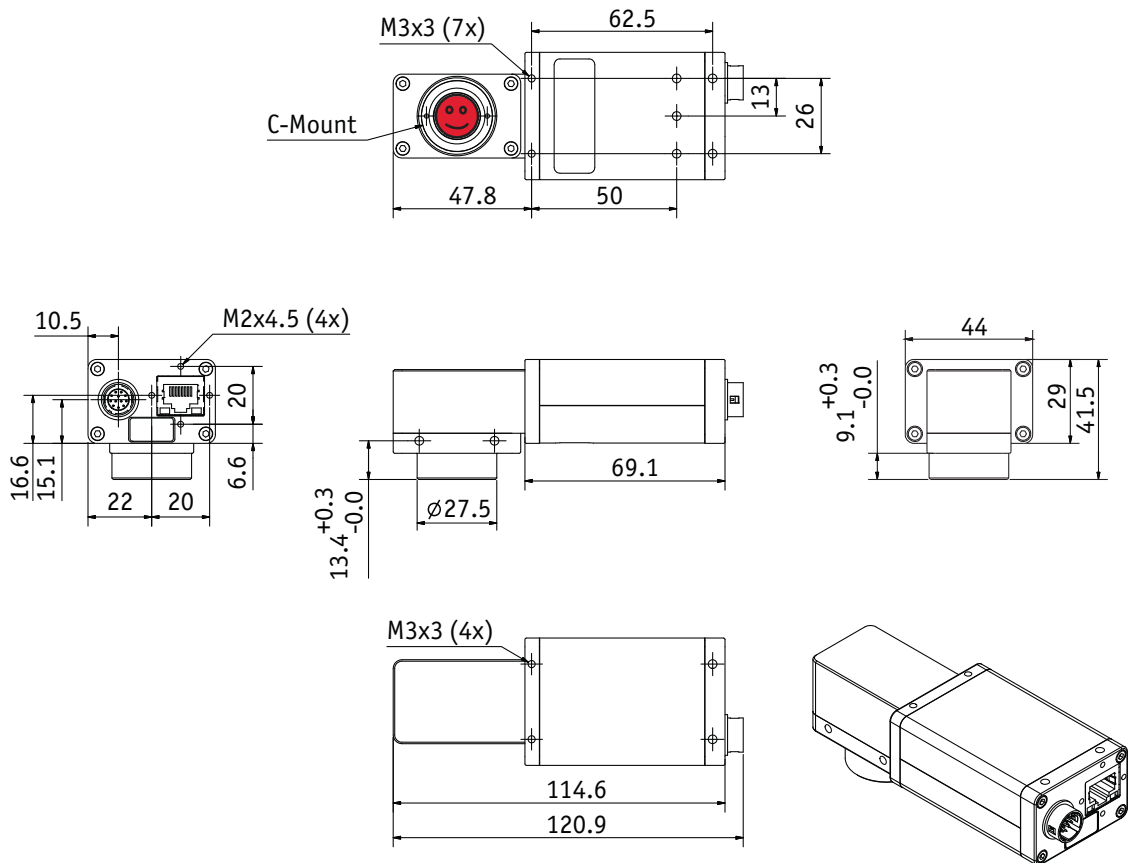

Figure 101: Camera dimensions for non-PoE Manta W270 S90 cameras up to serial number 503323258

Manta board level (non-POE)

13-pole I/O connector: Molex PicoBlade Vertical Header 53047-1310 Receptacle Housing 51021-1300 Crimp Terminal 13 x 50079-8000	1 = GND (for RS232, Ext PWR)	7 = GND (for Inputs)	<u>FFC45 cable length:</u> ----- FFC45 L = 56 mm K7500307 FFC45 L = 110 mm K7500318 FFC45 L = 152 mm 1817 FFC45 L = 200 mm 1824
	2 = Ext PWR input	8 = RxD 9 = TxD	
	3 = PMW-Out	10 = Power Input (for Output ports)	
	4 = Input 1	11 = Input 2	
	5 = not used	12 = Output 2	
6 = Output 1	13 = Chassis GND		

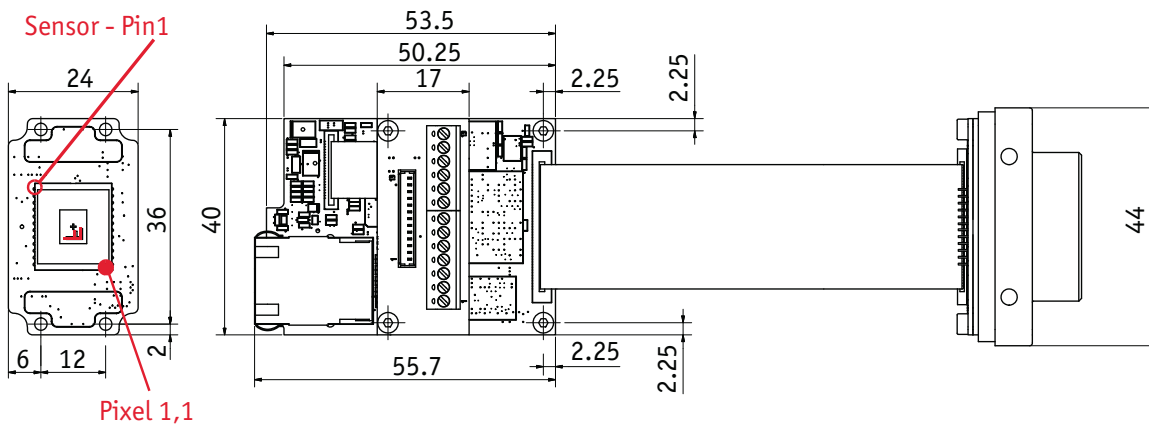
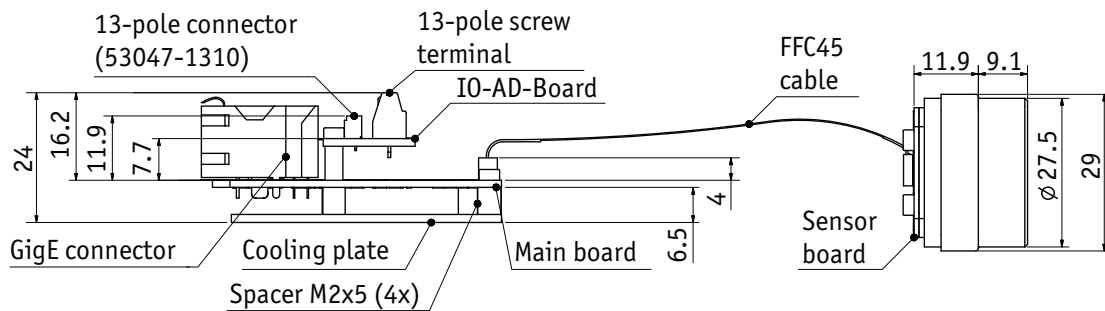

Figure 102: Camera dimensions for non-PoE **Manta board level** cameras up to serial number 503323258

Camera I/O connector pin assignment

Non-PoE Manta cameras up to serial number 503323258

Note Manta G-145-30fps / 201-30fps non-PoE cameras up to serial number 503323258 behave like PoE cameras.



See [Camera I/O connector pin assignment \(incl. PoE\)](#) on page 100.

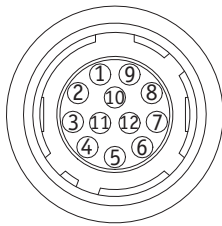

Pin	Signal	Direction	Level	Description
1	Camera GND	In	GND for RS232 and ext. power	Ground for camera power supply and RS232
2	Camera Power	In	8–30 V DC	Camera power supply
3	Video Type Auto Iris Out	Out	---	Video type auto iris (≥ FW 1.44)
4	In 1	In	$U_{in}(high) = 2.5-6.0\text{ V}$ $U_{in}(low) = 0-0.8\text{ V}$ up to 36 V with external resistor of 3.3 kΩ in series	Input 1 (SyncIn1)
5	---	---	---	---
6	Out 1	Out	Open emitter, max. 20 mA	Output 1 (SyncOut1)
7	Isolated IO GND	In/Out	Common GND for In/Out	Isolated input and output signal ground
8	RxD RS232	In	RS232	Terminal receive data
9	TxD RS232	Out	RS232	Terminal transmit data
10	Isolated Out Power	In	Common VCC for outputs max. 30 V DC	Power input for opto-isolated outputs
11	In 2	In	$U_{in}(high) = 2.5-6.0\text{ V}$ $U_{in}(low) = 0-0.8\text{ V}$	Input 2 (SyncIn2)
12	Out 2	Out	Open emitter, max. 20 mA	Output 2 (SyncOut2)

Table 89: Camera I/O connector pin assignment for non-PoE Manta cameras up to serial number 503323258

Status LEDs

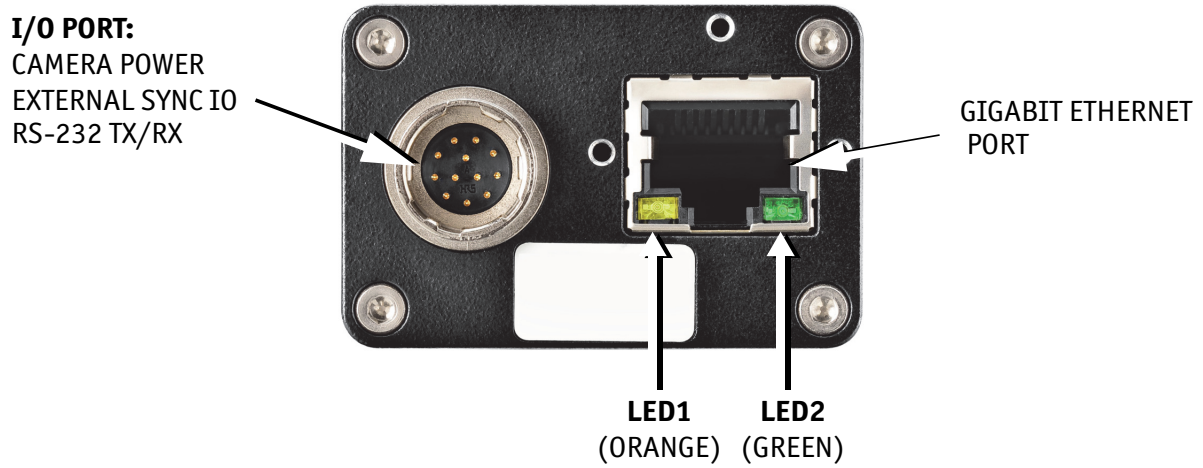

Figure 103: Example: Rear view of non-PoE Manta cameras up to serial number 503323258

The tables below describe the status LEDs of non-PoE Manta cameras up to serial number 503323258.

LED 1 color	Status
Solid orange	Ethernet link with 1 Gbit/s established
Flashing orange	Ethernet activity with 1 Gbit/s

Table 90: Status LED 1 (**orange**) of non-PoE Manta cameras up to serial number 503323258.

LED 2 color	Status
Solid green	Ethernet link with 100 Mbit/s established
Flashing green	Ethernet activity with 100 Mbit/s

Table 91: Status LED 2 (**green**) of non-PoE Manta cameras up to serial number 503323258.

Index

A

accuracy	
sensor position	152
acquiring (signal)	108
acquisition stream	108
AcquisitionTriggerReady (signal)	107

B

bandwidth	
save in RAW-mode	127
BAYER demosaicing	127
BAYER mosaic	127
BAYER to RGB	
color interpretation	127
Block diagram	
Manta color CMOS cameras	115
Manta G-235 color camera	115
Manta G-235 monochrome camera	114
Manta monochrome CMOS cameras	114
Manta type A color camera)	112
Manta type A monochrome camera	112
Manta type B color camera	113
Manta type B monochrome camera	113

C

camera	
rear view	104
camera dimensions	71, 87
1 x GigE	88
camera interfaces	99
camera lenses	66
CE	25
Cleaning instructions	19, 21
color information	127
color interpolation	127
common vcc	
outputs	100, 159
Compressed air	22, 23
consequence	
BAYER demosaicing	128
Cross section C-Mount	
type A	85
type B	97

Cross section CS-Mount

type A	86
type B	98

D

data path	112
declaration of conformity	25
document history	8
duration of sensor exposure	107
Dust-free clean-room	21

E

Exceptions for non-PoE Manta cameras up to serial number 503323258	153
I/O connector pin assignment	159
Manta board level (non-POE)	158
Manta standard housing (1 x GigE)	153
Manta W270 housing	156
Manta W270 S90 housing	157
Manta W90 housing	154
Manta W90 S90 housing	155
Status LEDs	160
exposing (signal)	107
exposing (trigger)	110
exposure (definition)	110
exposure cycle (trigger)	110
exposure start delay (signal)	110
exposure time value (trigger)	110
external trigger	107
external trigger at SyncIn1	108
external trigger at SyncIn2	108

F

FCC Class B	25
focal length	67
frame readout	108
frame trigger	107
FrameReadout (signal)	108
FrameTrigger (signal)	107
FrameTriggerReady (signal)	107

G

general purpose output (GPO)	107
GenICam	24
Gigabit Ethernet	24

Gigabit Ethernet interface	24	Standard board level variants	93
GigE	24	Standard housing	88
GigE Vision	24	minimum pulse width	
GND for ext. power	100, 159	MANTA	101
GPO (general purpose output)	107	O	
I		output	
Identifying impurities	20	block diagram	108
idle (signal)	110	signals	107
imaging (signal)	108, 110	outputs	107
input		common vcc	100, 159
block diagram	107	general	107
inputs		P	
general	107	PoE	13, 18, 26, 99, 100
in detail	107	power	
integrating light (trigger)	110	GND	100, 159
interline boundary	111	propagation delay (trigger)	109
interline time (signal)	110	R	
interpolation		reading out data (trigger)	110
BAYER demosaicing	127, 128	readout (definition)	110
BAYER to RGB	127	readout data (trigger)	110
color	127	rear view of camera	104
L		registered exposure time (signal)	110
legal notice	2	RoHS (2002/95/EC)	25
Locating impurities	21	RS232	100, 159
logic trigger	107	RxD_RS232	100, 159
logic trigger (definition)	109	S	
M		sensor position accuracy	152
Manta G-223/419 board level cameras		sensor row readout cycles	110
C-Mount	94	software trigger	107
CS-Mount	95	specifications	26
M12-Mount	96	spectral sensitivity	
Manta type A		Manta G-031B	28
Standard angled-head housings	73	Manta G-031C	28
Standard board level variants	77	Manta G-032B	30
Standard housing	72	Manta G-032C	30
Manta type A board level (non-PoE)		Manta G-033B	32
C-Mount	79	Manta G-033C	32
CS-Mount	81	Manta G-046B	34
M12-Mount	83	Manta G-046C	34
Manta type A board level (PoE)		Manta G-095B	36
C-Mount	80	Manta G-095C	36
CS-Mount	82	Manta G-125B	38
M12-Mount	84	Manta G-125C	38
Manta type B		Manta G-145B	40
Standard angled-head housings	89	Manta G-145B NIR	42

Manta G-145C	40	trigger ready (signal)	110
Manta G-146B	44	trigger rules	110
Manta G-146C	44	tripod adapter	89
Manta G-201B	46	tripod dimensions	71, 87
Manta G-201C	46	U	
Manta G-223B / G-223NIR	48	user trigger (definition)	109
Manta G-223C	48	W	
Manta G-235B	50	Warranty	19
Manta G-235C	50	Warranty precautions	19
Manta G-282B	52		
Manta G-282C	52		
Manta G-283B	54		
Manta G-283C	54		
Manta G-419B / G-419NIR	56		
Manta G-419C	56		
Manta G-504B	58		
Manta G-504C	58		
Manta G-505B	60		
Manta G-505C	60		
Manta G-609B	62		
Manta G-609C	62		
Manta G-917B	64		
Manta G-917C	64		
spectral transmission			
IR cut filter	66		
type Hoya C5000	66		
start acquisition	107		
Strobe1 (signal)	108		
styles	17		
symbols	17		
SyncIn1 (signal)	108		
SyncIn2 (signal)	108		
SyncOutGpoLevels	107		
system components	66		
T			
time delay (trigger)	110		
timing diagram			
trigger	109		
Tpd (definition)	109		
trigger			
timing diagram	109		
trigger definitions	109		
trigger jitter (definition)	110		
trigger latency (definition)	110		
trigger latency time	110		