



## 1394 Installation Manual

V8.1.0

17 March 2015

Allied Vision Technologies GmbH  
Taschenweg 2a  
D-07646 Stadtroda / Germany

 Allied Vision

## Legal notice

### For customers in the U.S.A.

This equipment has been tested and found to comply with the limits for a Class B digital device, pursuant to Part 15 of the FCC Rules. These limits are designed to provide reasonable protection against harmful interference when the equipment is operated in a residential environment. This equipment generates, uses, and can radiate radio frequency energy and, if not installed and used in accordance with the instruction manual, may cause harmful interference to radio communications. However there is no guarantee that interferences will not occur in a particular installation. If the equipment does cause harmful interference to radio or television reception, the user is encouraged to try to correct the interference by one or more of the following measures:

- Reorient or relocate the receiving antenna.
- Increase the distance between the equipment and the receiver.
- Use a different line outlet for the receiver.
- Consult a radio or TV technician for help.

You are cautioned that any changes or modifications not expressly approved in this manual could void your authority to operate this equipment. The shielded interface cable recommended in this manual must be used with this equipment in order to comply with the limits for a computing device pursuant to Subpart B of Part 15 of FCC Rules.

### For customers in Canada

This apparatus complies with the Class B limits for radio noise emissions set out in the Radio Interference Regulations.

### Pour utilisateurs au Canada

Cet appareil est conforme aux normes classe B pour bruits radioélectriques, spécifiées dans le Règlement sur le brouillage radioélectrique.

### Life support applications

These products are not designed for use in life support appliances, devices, or systems where malfunction of these products can reasonably be expected to result in personal injury. Allied Vision Technologies customers using or selling these products for use in such applications do so at their own risk and agree to fully indemnify Allied for any damages resulting from such improper use or sale.

### Trademarks

Unless stated otherwise, all trademarks appearing in this document of Allied Vision Technologies are brands protected by law.

### Warranty

The information provided by Allied Vision Technologies is supplied without any guarantees or warranty whatsoever, be it specific or implicit. Also excluded are all implicit warranties concerning the negotiability, the suitability for specific applications or the non-breaking of laws and patents. Even if we assume that the information supplied to us is accurate, errors and inaccuracy may still occur.

### Copyright

All texts, pictures and graphics are protected by copyright and other laws protecting intellectual property. It is not permitted to copy or modify them for trade use or transfer, nor may they be used on web sites.

## Allied Vision Technologies GmbH 03/2015

All rights reserved.

Managing Director: Mr. Frank Grube

Tax ID: DE 184383113

Headquarters:

Taschenweg 2A

D-07646 Stadtroda, Germany

Tel.: +49 (0)36428 6770

Fax: +49 (0)36428 677-28

e-mail: [info@alliedvision.com](mailto:info@alliedvision.com)

# Contents

<b>Connect with us</b> .....	6
<b>Introduction</b> .....	7
Document history .....	7
Manual overview .....	13
Conventions used in this manual .....	14
Styles .....	14
Symbols .....	14
More information .....	15
Accessories .....	15
Software .....	15
Technical Manuals .....	16
<b>Safety instructions</b> .....	18
General safety instructions .....	18
Sensor safety instructions .....	19
FireWire safety instructions .....	20
FireWire hot-plug and screw-lock precautions .....	20
Changing filters safety instructions .....	21
Guppy: changing filters safety instructions .....	21
Pike/Oscar: changing filters safety instructions .....	22
Marlin/Stingray/Guppy PRO: changing filters safety instructions .....	22
Cautions: Connecting a camera .....	23
Pike/Stingray GOF connectors .....	23
Safety instructions for board level cameras .....	24
<b>Camera cleaning instructions</b> .....	26
Warranty .....	26
Avoiding the necessity of camera cleaning .....	27
Is it an impurity? – Identifying impurities .....	28
Where is the impurity? – Locating impurities .....	28
Cleaning Instructions .....	30
<b>Allied Vision 1394 cameras: installing hardware</b> .....	33
Hardware conditions .....	34
FireWire hot-plug and screw-lock precautions .....	35
Overview hardware installation .....	36
Installing IEEE 1394 adapter .....	36
Connecting camera to PC or laptop .....	36
<b>Camera interfaces</b> .....	38
IEEE 1394a port pin assignment	

(Oscar, Marlin, Guppy) .....	40
Board level camera (Guppy): IEEE 1394a port pin assignment .....	41
IEEE 1394b port pin assignment	
(Guppy PRO, Pike, Stingray) .....	42
Board level camera (Stingray): IEEE 1394b port pin assignment .....	43
Pike/Stingray fiber infos and cautions .....	44
Camera I/O connectors (12 pin) order numbers and cables: Guppy PRO, Stingray, Pike, Marlin, Oscar .	
46	
Camera I/O connectors (8 pin) order numbers and cables: Guppy .....	47
Stingray camera interfaces .....	48
Stingray camera I/O connector pin assignment .....	48
Stingray input description .....	49
Stingray input block diagram .....	49
Stingray delay and minimum pulse width.....	50
Test conditions .....	50
Stingray output description .....	51
Stingray block diagram .....	51
Stingray delay.....	52
<b>Test conditions</b> .....	<b>52</b>
Stingray data .....	53
Stingray power .....	53
Stingray board level camera:	
I/O pin assignment .....	54
Pike camera interfaces .....	55
Pike camera I/O connector pin assignment.....	55
Pike input description (not Pike F-505) .....	56
Pike input block diagram.....	56
Pike delay and minimum pulse width .....	57
Input description of Pike F-505 .....	58
Pike F-505 input block diagram .....	58
Pike F-505 delay and minimum pulse width.....	59
Pike output description .....	60
Pike output block diagram .....	60
Pike delay .....	61
<b>Test conditions</b> .....	<b>61</b>
Pike data .....	62
Pike power.....	62
Guppy PRO camera interfaces.....	63
Guppy PRO camera I/O connector pin assignment.....	63
Guppy PRO input description .....	64
Guppy PRO input block diagram .....	64
Guppy PRO delay and minimum pulse width .....	65
Guppy PRO output description .....	66
Guppy PRO block diagram .....	66
Guppy PRO delay .....	68
Guppy PRO data .....	68
Guppy PRO power .....	68
Guppy camera interfaces.....	69

Guppy camera I/O connector pin assignment.....	69
Guppy (housing) .....	69
Guppy (board level) .....	70
Guppy input description .....	71
Guppy (housing) input block diagram .....	71
Guppy delay and minimum pulse width .....	72
Guppy output description .....	73
Guppy output block diagram .....	73
Guppy delay .....	74
<b>Test conditions .....</b>	<b>74</b>
Guppy (board level) IO block diagram .....	75
Guppy data .....	75
Guppy power .....	75
Marlin camera interfaces.....	76
Marlin camera I/O connector pin assignment.....	76
Marlin input description .....	77
Marlin input block diagram .....	77
Marlin delay and minimum pulse width .....	78
Marlin output description .....	79
Marlin output block diagram .....	79
Marlin delay .....	80
Marlin data .....	80
Marlin power.....	80
Oscar camera interfaces.....	81
Oscar camera I/O connector pin assignment.....	81
Oscar input description .....	82
Oscar input block diagram .....	82
Oscar delay and minimum pulse width .....	83
Oscar output description .....	84
Oscar output block diagram .....	84
Oscar delay .....	85
Oscar data .....	85
Oscar power.....	85
<b>Firmware update.....</b>	<b>86</b>
<b>Index.....</b>	<b>87</b>

## Connect with us

**Connect with Allied Vision colleagues by function,  
find an Allied Vision office or distributor:**

<http://www.alliedvision.com/en/contact>

### **Email**

[info@alliedvision.com](mailto:info@alliedvision.com)

[support@alliedvision.com](mailto:support@alliedvision.com)

### **Telephone**

EMEA: +49 36428-677-0

The Americas: +1 978-225-2030

Asia-Pacific: +65 6634-9027

China: +86 (21) 64861133headquarters

### **Headquarters**

Allied Vision Technologies GmbH

Taschenweg 2a, 07646 Stadtroda, Germany

Tel: +49 (0)36428 6770, Fax: +49 (0)36428 677-28

President/CEO: Frank Grube

Registration Office: AG Jena HRB 208962

# Introduction

This **1394 Installation Manual** describes the hardware installation procedures for the following 1394 Allied Vision cameras: Oscar, Marlin, Guppy, Pike, Stingray and Guppy PRO.

The **1394 Installation Manual** answers questions about putting Allied Vision cameras into operation, about safety warnings, pin assignments on I/O connectors and 1394a/b connectors. Learn how to get more information at our website (accessories), how to get information about software applicable with Allied Vision cameras and how to get deep information from the Technical Manual of each camera family.

## Note



**Please read through this manual carefully before installing the hardware on your PC or laptop (FireWire card, cables) and operating the Allied Vision cameras.**

## Document history

Version	Date	Remarks
V2.0.0	31.03.08	New Manual - RELEASE status
V2.1.0	21.05.08	Schematics standardized in Chapter Cautions: Connecting a camera on page 23ff. Marked Pin 1 with blue color in Figure 10: Board level camera (Guppy): IEEE 1394 FireWire connector 1 (view on pins) on page 41
<b>to be continued on next page</b>		

Table 1: Document history

Version	Date	Remarks
		continued from last page
V2.2.0	19.08.08	<p>Inserted Latching precautions for 1394a cables in Chapter Connecting camera to PC or laptop on page 36</p> <p>Corrected ordering number in Figure 3: Removing IR cut filter/ protection glass using special tool (E9020001) on page 30</p> <p>Restructuring Chapter Camera interfaces on page 38ff.</p> <p>New measurements of inputs and outputs and standardized descriptions of I/Os for all Allied Vision 1394 camera families in Chapter Camera interfaces on page 38ff.</p> <p>New photo of Stingray camera with new screws on either side of the camera on title page</p> <p>New photo of Stingray backside in Figure 8: Example: Rear view of Stingray camera (2x 1394b copper) on page 38</p> <p>New photos of Dolphin, Oscar, Marlin, Guppy, Pike, Stingray (with HIROSE and 1394 copper) in Table 5: Rear view of Allied Vision 1394 cameras (HIROSE and 1394 copper) on page 39</p> <p>New photos Pike fiber and Stingray fiber (with HIROSE and 1394b GOF and 1394b copper) in Table 6: Rear view of Allied Vision 1394 cameras (HIROSE and 1394b GOF/copper) on page 39</p> <p>New photo of Pike fiber (with HIROSE and 1394b GOF and 1394b copper) in Figure 15: Rear view of Pike camera (1394b: 1 x GOF, 1 x copper) (Stingray similar) on page 45</p> <p>Deleted Direct FirePackage in Chapter Software on page 15</p> <p>Revised Chapter Software on page 15f.</p> <p>New Stingray board level CAD drawings (1394b connectors are now (partially) visible):</p> <p>in Figure 12: Board level camera (Stingray): two IEEE 1394b FireWire connectors on page 43 and</p> <p>in Figure 21: Stingray board level camera: I/O pin assignment on page 54</p>
V2.3.0	12.09.08	<p>New Stingray board level CAD drawing with new Molex 1.25 mm Pitch PicoBlade Wire-to-Board Header (53047-1310) and new cable lengths in Figure 12: Board level camera (Stingray): two IEEE 1394b FireWire connectors on page 43 and in Figure 21: Stingray board level camera: I/O pin assignment on page 54</p>
<b>to be continued on next page</b>		

Table 1: Document history



Version	Date	Remarks
		continued from last page
V3.0.0	08.10.08	New Stingray F-125B/C: see Figure 20: Stingray output switching times on page 52
V4.0.0	21.10.08	New Stingray F-504B/C see Figure 20: Stingray output switching times on page 52
V5.0.0	24.10.08	New Guppy F-503B/C see Guppy delay on page 74
V5.1.0	28.01.09	New CAD drawings (hexagon socket head cap screw ISO 4762): <ul style="list-style-type: none"> <li>• Figure 12: Board level camera (Stingray): two IEEE 1394b FireWire connectors on page 43</li> <li>• Figure 21: Stingray board level camera: I/O pin assignment on page 54</li> </ul> Added 50 mA as max. input current on page 71. <b>Dolphin camera family discontinued</b>
V5.2.0	28.05.09	Changed <i>Camera In 1 signal</i> $U_{in}$ (high) from 2 V to <b>2.4 V</b> in Figure 33: Guppy (housing): Camera I/O connector pin assignment on page 69 Added <b>minimum pulse width</b> (inputs) for all camera families: <ul style="list-style-type: none"> <li>• <b>Stingray:</b> see Chapter Stingray delay and minimum pulse width on page 50</li> <li>• <b>Pike:</b> see Chapter Pike delay and minimum pulse width on page 57</li> <li>• <b>Guppy:</b> see Chapter Guppy delay and minimum pulse width on page 72</li> <li>• <b>Marlin:</b> see Chapter Marlin delay and minimum pulse width on page 78</li> <li>• <b>Oscar:</b> see Chapter Oscar delay and minimum pulse width on page 83</li> </ul>
<b>to be continued on next page</b>		

Table 1: Document history

Version	Date	Remarks
		continued from last page
V5.3.0	16.09.09	<p>New Stingray front flange:</p> <ul style="list-style-type: none"> <li>Title page: new Stingray photo</li> <li>Table 4: How to remove the filter/protection glass on page 29 (new: Stingray Rev. 3)</li> <li>Figure 12: Board level camera (Stingray): two IEEE 1394b FireWire connectors on page 43</li> <li>Figure 21: Stingray board level camera: I/O pin assignment on page 54</li> </ul> <p>New Pike front flange:</p> <ul style="list-style-type: none"> <li>Title page: new Pike photo</li> <li>Table 4: How to remove the filter/protection glass on page 29 (Pike Description: both screws top (middle) and the right side)</li> </ul>
V6.0.0	07.05.10	<p><b>Minor corrections:</b></p> <ul style="list-style-type: none"> <li>Corrected Camera Input 1: <math>U_{in}(\text{high}) = 3.8 \text{ V} \dots 5 \text{ V}</math> <math>U_{in}(\text{low}) = 0 \text{ V} \dots 1 \text{ V}</math> in Figure 33: Guppy (housing): Camera I/O connector pin assignment on page 69</li> </ul> <p><b>Added Pike F-1100 and Pike F-1600:</b></p> <ul style="list-style-type: none"> <li>Title page: photo of Pike F-1000/F-1600</li> <li>Pike delay on page 61</li> </ul> <p><b>Discontinuation of Marlin F-131C</b></p> <p>New links to new Allied Vision website</p> <ul style="list-style-type: none"> <li>Chapter Connect with us on page 6</li> </ul>
<b>to be continued on next page</b>		

Table 1: Document history

Version	Date	Remarks
continued from last page		
V7.0.7	30.11.10	<p>Revised Manual (added Guppy PRO) — RELEASE status</p> <ul style="list-style-type: none"> <li>• Added Stingray in Chapter Marlin/Stingray/Guppy PRO: changing filters safety instructions on page 22</li> <li>• Changed URLs in this chapter to the new structured Allied Vision website.</li> </ul> <p><b>Added Guppy PRO cameras:</b></p> <ul style="list-style-type: none"> <li>• Added photo of Guppy PRO on title page</li> <li>• Added Guppy PRO in Chapter IEEE 1394b port pin assignment (Guppy PRO, Pike, Stingray) on page 42</li> <li>• Added Guppy PRO in Chapter Camera I/O connectors (12 pin) order numbers and cables: Guppy PRO, Stingray, Pike, Marlin, Oscar on page 46</li> <li>• Added Chapter Guppy PRO input block diagram on page 64</li> <li>• Chapter Guppy PRO delay and minimum pulse width on page 65</li> <li>• Chapter Guppy PRO block diagram on page 66</li> <li>• Removed RS232: Chapter Guppy PRO camera I/O connector pin assignment on page 63</li> <li>• Chapter Guppy PRO delay on page 68</li> </ul>
V7.0.8	07.01.11	<ul style="list-style-type: none"> <li>• Minor corrections</li> <li>• Added caution (sensor damage) in Chapter Sensor safety instructions on page 19</li> <li>• Added Windows 7 support in Chapter Allied Vision 1394 cameras: installing hardware on page 33</li> <li>• Recommended software package for vendor-specific feature control is now Universal Package, see Chapter Software on page 15.</li> <li>• Note: Only SmartView of FirePackage provides extended GUI control options to evaluate Allied Vision 1394 camera vendor-specific features, see Chapter Overview hardware installation on page 36.</li> </ul>
<b>to be continued on next page</b>		

Table 1: Document history

Version	Date	Remarks
		continued from last page
V7.0.9	04.04.11	<ul style="list-style-type: none"> <li>Added Guppy PRO: Changing filter instructions same as Marlin/Stingray: see Chapter Marlin/Stingray/Guppy PRO: changing filters safety instructions on page 22 and Table 4: How to remove the filter/protection glass on page 29</li> <li>Added Singapore: see Chapter Connect with us on page 6</li> <li>Revised camera delay descriptions:               <ul style="list-style-type: none"> <li>Chapter Stingray delay on page 52</li> <li>Chapter Pike delay on page 61</li> <li>Chapter Guppy PRO delay on page 68</li> <li>Chapter Guppy delay on page 74</li> <li>Chapter Marlin delay on page 80</li> <li>Chapter Oscar delay on page 85</li> </ul> </li> </ul>
V8.0.0	13.08.12	<p>Added Guppy PRO F-033, Guppy PRO F-046, and Guppy PRO F-095C</p> <ul style="list-style-type: none"> <li>Chapter Guppy PRO input block diagram on page 64</li> <li>Chapter Guppy PRO delay and minimum pulse width on page 65</li> <li>Chapter Guppy PRO block diagram on page 66</li> <li>Chapter Guppy PRO delay on page 68</li> </ul> <p>Changed Pike trigger input voltage</p> <ul style="list-style-type: none"> <li>Pike trigger input voltage (GPIIn1 and GPIIn2) changed from 2 V to <b>3 V at min. input current of 5 mA</b>, see Chapter Pike camera I/O connector pin assignment on page 55.</li> </ul>
V8.1.0	17.03.2015	<ul style="list-style-type: none"> <li>Updated layout for new company branding</li> <li>Updated links to the rebranded company website</li> <li>Updated Chapter Connect with us on page 6</li> </ul>

Table 1: Document history

## Manual overview

The manual overview describes each chapter of this manual shortly.

- Chapter Connect with us on page 6 lists contact data for both: technical information / ordering and commercial information.
- Chapter Introduction on page 7 (this chapter) gives you the document history, a manual overview and conventions used in this manual (styles and symbols). Furthermore you learn how to get more information on **Allied Vision accessories, software, and Technical Manuals**.
- Chapter Safety instructions on page 18 describes safety instructions for Allied Vision 1394 cameras in general and special safety instructions for camera families/models.
  - **Read this chapter carefully before operating any Allied Vision 1394 camera.**
  - **Follow all safety instructions, especially the cautions when connecting cameras.**
  - **Take special care when operating board level cameras (Caution-ESD, general warnings, loading and dirty environments). Read all notes and safety instructions before operating any Allied Vision board level camera.**
- Chapter Allied Vision 1394 cameras: installing hardware on page 33 describes the hardware installation procedures. In this chapter you get links to our website (accessories) and you learn how to get more information on installing software.
  - **Read this chapter before installing any hardware.**
  - **Read and follow the FireWire hot plug precautions.**
  - **Read and follow the caution when connecting a camera to PC or laptop.**
- Chapter Camera interfaces on page 38 describes the interfaces of all Allied Vision 1394 cameras (I/O connector and IEEE 1394a and 1394b connectors).
  - **Read all notes and cautions carefully.**
- Chapter Firmware update on page 86 describes how to get information on firmware updates.

## Conventions used in this manual

To give this manual an easily understood layout and to emphasize important information, the following typographical styles and symbols are used:

### Styles

Style	Function	Example
Bold	Programs, inputs or highlighting important things	<b>bold</b>
Courier	Code listings etc.	Input
Upper case	Register	REGISTER
Italics	Modes, fields	<i>Mode</i>
Parentheses and/or blue	Links	( <a href="#">Link</a> )

Table 2: Styles

### Symbols

**Note** This symbol highlights important information.



**Caution** This symbol highlights important instructions. You have to follow these instructions to avoid malfunctions.



**Caution-ESD** This symbol highlights important ESD instructions. Only qualified personnel is allowed to install and operate components marked with this symbol.



**www** This symbol highlights URLs for further information. The URL itself is shown in blue.



Example:

<http://www.alliedvision.com>

## More information

In this chapter you get more information on **Allied Vision accessories, software, and Technical Manuals**.

### Accessories

#### Note



Allied Vision Technologies offers a wide range of accessories for the use of Allied Vision 1394 cameras and the easy integration in already existing applications.

- **IEEE 1394a** and **IEEE 1394b** accessories (interface cards, hubs and repeaters, cables)
- **Lenses** (for cameras with sensors of type 1/3, 1/2, 1, 2/3 and 1.2)

#### www



For more information on accessories and for ordering, see:

<http://www.alliedvision.com/en/contact>

### Software

#### Note



Allied Vision 1394 cameras are compliant to IIDC V1.30/V1.31 and offer many more functions than specified in the IIDC V1.30/V1.31: vendor-specific features. These features are accessible via direct register access, or by using special functions provided in the following Software Packages:

- Universal Package
- Fire4Linux

To evaluate all vendor-specific features with a GUI tool use SmartView (which is part of the FirePackage).

All software packages are provided free of charge and contain:

- Drivers
- Software Development Kit (SDK) for camera control and image acquisition
- Examples based on the provided APIs of the SDK
- Documentation and release notes
- Viewer application to operate/configure the cameras and access/test the vendor-specific features.

---

**www**

For Allied Vision software packages (including documentation and release notes) see:

<http://www.alliedvision.com/en/support/software-downloads>

---

**www**

In addition to Software Packages, Allied Vision Technologies offers special Integration Packages to integrate Allied Vision 1394 cameras into any third-party vision software that supports the IIDC standard.

For more information see:

<http://www.alliedvision.com/en/support/software-downloads>

Here you also find the Allied Vision Software Packages for download and additional software documentation:

- FirePackage User Guide
- FirePackage64 User Guide
- Active FirePackage User Guide
- [tbd: Fire4Linux User Guide]
- [tbd: Fire4Linux Command Reference Guide]
- Release Information
- Operating Allied Vision 1394 cameras with SmartView (this manual is part of the FirePackage)

## Technical Manuals

---

**Note**

Besides hardware installation procedures (this guide) and the software documentation there is an in-depth description of all Allied Vision 1394 cameras in the so-called Technical Manuals (one for each camera family):

- Oscar Technical Manual
- Marlin Technical Manual
- Guppy Technical Manual
- Guppy PRO Technical Manual
- Pike Technical Manual
- Stingray Technical Manual

Here you find: technical data, functional descriptions, features of the camera and how to use, register descriptions (IIDC V1.30/V1.31 and Allied Vision advanced registers)



www



For downloading the Technical Manuals go to:

<http://www.alliedvision.com/en/support/technical-documentation>

# Safety instructions

This chapter describes safety instructions/cautions valid for all Allied Vision 1394 camera families and special safety instructions/cautions depending on the camera family/model used.

## General safety instructions

### Note

---



- There are no switches or parts inside the camera that require adjustment. The guarantee becomes void upon opening the camera casing.
- If the product is disassembled, reworked or repaired by other than a recommended service person, Allied Vision or its suppliers will take no responsibility for the subsequent performance or quality of the camera.
- The camera does **not** generate dangerous voltages internally. However, because the IEEE 1394a and 1394b standard permit cable power distribution at voltages higher than 36 V, **please note that various country-specific regulations apply.**

### Note

---



- All **color models** are equipped with an **optical filter** to eliminate the influence of infrared light hitting the sensor. Please be advised that, as a side effect, this filter reduces sensitivity in the visible spectrum. The optical filter is part of the back focus ring, which is threaded into the C-Mount.
- **Monochrome models** are delivered with a **sensor protection glass** mounted in the back focus ring to ensure maximum sensitivity. In certain applications and depending on the lighting source and optics, the use of either IR blocking or IR passing filter may be required to improve the image quality.

## Sensor safety instructions

### Caution



#### Sensor may be damaged

Light intensity or exposure time exceeding the saturation of the sensor may damage the sensor irreparably.

#### This may occur in following situations:

- Laser light hitting the sensor directly
- Bright light sources (e.g. sunlight) hitting the sensor directly
- Camera is exposed to X-rays

#### Damages may be caused by:

- Overheating of color filters, microlenses or pixel structures
- Accelerated aging of color filters or pixel structures

#### To avoid sensor damage

- Use light source with lower intensity
- Use external shutter
- Use optical filters
- Use lens cap (when camera not in use)
- Vary local light spot / laser spot on sensor
- X-rays:
  - Keep camera out of X-ray path. Guide the light source via mirrors to the sensor. Or
  - Use lead glass to protect lens and sensor. Use lead jacket for the body of the camera.

**The warranty does not cover damaged cameras caused by X-ray applications or too much light/laser light.**

# FireWire safety instructions

## FireWire hot-plug and screw-lock precautions

### Caution



### Hot-plug precautions

- Although FireWire devices can **theoretically** be hot-plugged without powering down equipment, **we strongly recommend turning the computer power off, before connecting a digital camera** to it via a FireWire cable.
- **Static electricity or slight plug misalignment during insertion may short-circuit and damage components.**
- The physical ports **may be damaged by excessive ESD** (electrostatic discharge), when connected under powered conditions. It is good practice to ensure proper grounding of computer case and camera case to the same ground potential, before plugging the camera cable into the port of the computer. This ensures that no excessive difference of electrical potential exists between computer and camera.
- It is **very important not** to exceed an inrush current of 18 mJoule in 3 ms. (This means that a device, when powered via 12 V bus power must **never** draw more than 1.5 A, even not in the first 3 ms.)
- **Higher inrush current may damage the physical interface chip of the camera and/or the phy chip in your PC.**
- Whereas inrush current is not a problem for one Pike/Stingray camera, daisy chaining multiple cameras or supplying bus power via (optional) HIROSE power out to circuitry with unknown inrush currents needs careful design considerations to be on the safe side.

### Latching / screw-lock precautions

- **1394a cameras:** We strongly recommend using **only 1394a cables with latch connectors**, to insure a tight electrical connection that is resistant to vibration and gravity.
- **1394b cameras:** All Allied Vision 1394b camera and cables have **industrial screw-lock fasteners**, to insure a tight electrical connection that is resistant to vibration and gravity.
- **We strongly recommend using only 1394b adapter cards with screw-locks.**

## Changing filters safety instructions

### Caution



- Mount/dismount lenses and filters in a **dust-free environment**, and **do not** use compressed air (which can push dust into cameras and lenses).
- Use only **optical quality tissue**/cloth if you must clean a lens or filter.

Ask your dealer if you are not familiar with these procedures.

### Guppy: changing filters safety instructions

Old CS-/C-Mounting	New CS-/C-Mounting starting with serial no. 06/05-84312215
<p><b>CS-Mount models</b> have the filter or protection glass mounted directly in front of the sensor. Taking out the filter or protection glass is not possible at customer site.</p> <p>Ask your dealer for a camera with the respective filter already installed.</p>	<p><b>All models</b> have the filter or protection glass mounted directly in the CS-Mount adapter. (Standard delivery is a CS-Mount camera). Taking out the filter or protection glass is not possible at customer site.</p> <p>Ask your dealer for a camera with the respective filter already installed.</p>
<p>C-Mount models have the filter or protection glass mounted in the CS- to C-Mount extension adapter.</p> <p>Ask your dealer for an extension adapter with the intended filter already mounted.</p>	<p>In order to get a C-Mount camera, screw the 5 mm C-Mount adapter onto the CS-Mount camera. Unscrew the 5 mm C-Mount adapter to get again a CS-Mount camera.</p>
<p>Removing the <b>C-Mount adapter</b> opens the front section of the camera. This greatly enhances the risk for dust or particles to migrate on the sensor's protection glass.</p> <p>In order to remove the adapter:</p> <p>Hold the camera so that the adapter points downwards while changing the adapter. Use optical cleaning tissues for cleaning the sensor's protection glass if needed. <b>Never use compressed air</b> for cleaning purposes.</p> <p>Ask your dealer if you are not familiar with these procedures.</p>	<p>Removing the <b>CS-Mount adapter</b> opens the front section of the camera. This greatly enhances the risk for dust or particles to migrate on the sensor's protection glass.</p> <p>In order to remove the adapter:</p> <p>Hold the camera so that the adapter points downwards while changing the adapter. Use optical cleaning tissues for cleaning the sensor's protection glass if needed. <b>Never use compressed air</b> for cleaning purposes.</p> <p>Ask your dealer if you are not familiar with these procedures.</p>

Table 3: Old and new CS-/C-Mounting of Guppy cameras

## **Pike/Oscar: changing filters safety instructions**

### **Note**

---



- **Pike/Oscar** models only: **Changing filters** is achieved by changing back focus rings with the appropriate filter already mounted. Please be advised that back focus adjustment will be necessary in order to match C-Mount distance of 17.526 mm. Ask your dealer for further information or assistance.

## **Marlin/Stingray/Guppy PRO: changing filters safety instructions**

### **Note**

---



- **Marlin/Stingray/Guppy PRO** models only: For certain applications it may be recommended to take out the filter by means of a special tool which can be ordered from Allied Vision under the following number: E9020001.
- Taking out the filter requires special care. Ask your dealer to help you if you are not confident with the procedure.

## Cautions: Connecting a camera

### Caution



#### All cameras

- **Do not touch the shield of the camera cable** connected to a computer and the ground terminal of the lines at the same time.
- If you are charged: before touching the shield of the camera cable, make sure to discharge first (by touching the ground terminal of the lines).
- **Use only DC power supplies with insulated cases.** These are identified by having only **two** power connectors.
- Although IEEE 1394a and 1394b are functionally plug and play, the physical ports **may be damaged** by **excessive ESD** (electrostatic discharge), when connected under powered conditions. It is good practice to ensure proper grounding of computer case and camera case to the same ground potential, before plugging the camera cable into the port of the computer. This ensures that no excessive difference of electrical potential exists between computer and camera.
- If you feel uncomfortable with the previous advice or if you have no knowledge about the connectivity of an installation, **we strongly recommend powering down all systems before connecting or disconnecting a camera.**

## Pike/Stingray GOF connectors

### Caution



#### Special warning for all Pike/Stingray models with GOF connectors:

**GOF connectors are very sensitive. Any dust or dirt may cause damage.**

- Always keep the GOF connector and optical fiber plug clean.
- If GOF connection is not in use, keep GOF dust cover on the GOF connector.
- Reduce mating cycles to a minimum to prevent abrasion.
- Please note that optical fiber cables have a very limited deflection curve radius.

## Safety instructions for board level cameras

---

**Note**

---

Read the **Guppy Technical Manual** or **Stingray Technical Manual** and **this safety instructions** before use.

---

**Abuse or misapplication of the camera may result in limited warranty or cancelation of warranty.**

---

**Caution-ESD**

---

**Board level cameras: ESD warnings**

---

- Only **qualified personnel** is allowed to install and operate the Board level cameras.
- Board level cameras are delivered without housing. Handle the sensor board and main board with care. Do not bend the boards. Do not touch the components or contacts on a board. Hold a board by its edges.
- Sensor board and main board are sensitive to electrostatic discharge. To avoid possible damage, handle all static-sensitive boards and components in a static-safe work area. Follow the procedures below.
- **ESD (electrostatic discharge):** Static electricity can damage the sensor board or the main board of your Board level cameras. To prevent static damage, discharge static electricity from your body before you touch any of your board level cameras's electronic components, such as sensor board or main board. To do so, use a static-safe work area with static-dissipative mat and wear a static-dissipative wrist strap. Do not hold any components of your Board level cameras against your clothing. Even if you are wearing a wrist strap, your body is grounded but your clothes are not.
- Do not remove the sensor board and main board from its anti-static packaging unless your body is grounded.
- **ESD shielding:** To protect the boards from radiation of other modules or devices use a special ESD protective housing.



**Caution****Board level cameras: General Warnings**

- Be sure that all power to your board level cameras is switched off, before mounting the sensor board or making connections to the camera.
- Do not connect or disconnect any cables during an electrical storm.
- Do not use your board level cameras during an electrical storm.
- To help avoid possible damage to the sensor board or main board, wait 5 seconds after power is switched off, before connecting or disconnecting any cable to the board level cameras.
- Ensure that nothing rests on the cables of your board level cameras.
- Keep your board level cameras away from radiators and heat sources.
- Do not spill food or liquids on your board level cameras.

**Caution****Board level cameras: Loading**

- Avoid any mechanical forces to the board level cameras, the boards and its components, especially torsional, tensile and compressive forces. Any of these forces may result in damage of the board level cameras, the boards and its components.
- To avoid damages of the boards, provide cables with an external pull relief so that no force is applied to the connectors itself.

**Caution****Board level cameras: Dirty environments**

- Always use clean boards.
- To protect the boards from dirt like dust, liquids or swarf always use the board level cameras only in clean room environment or use a protective housing.

# Camera cleaning instructions

This section describes safety instructions/cautions valid for all Allied Vision 1394 camera families in case of cleaning lenses, optical filters/protection glass or sensors.

## Note



- Please read these instructions before you contact your Allied Vision camera dealer for assistance.
- Ask your Allied Vision camera dealer if you are not familiar with the procedures described below.

## Warranty

### Caution



#### Warranty precautions

- To ensure your warranty remains in force:
  - Do not open the camera housing.
  - Follow instructions described below.
  - Use only optical quality tissue/cloth if you must clean a lens or filter.
  - Use only optics cleaner (60% ethyl alcohol, 40% ether). Never use aggressive cleaners like benzine or spirit. Such cleaners may destroy the surface.
  - **Do not use compressed air which can push dust into camera and lens.**
- Allied Vision does not warranty against any physical damage to the sensor/filter/protection glass or lenses. **Use utmost care when cleaning optical components.**

### Caution



#### General warnings

- Do not touch any optical component with bare fingers. Oil or other impurities may damage the surface.
- Only follow the processes described below if you are familiar with these procedures and if you have the necessary equipment.
- If you are uncomfortable with the outlined precautions, please return your camera to Allied Vision for cleaning.

**Caution-ESD** ESD warnings

**Image sensors are easily damaged by static discharge (ESD).**

- Please use anti-static gloves, clothes and materials. Also use conductive shoes.
- Install a conductive mat on the floor and/or working table to prevent the generation of static electricity.

## Avoiding the necessity of camera cleaning

When changing camera lenses please follow these procedures:

- Simply hold the camera with the C-mount opening towards the floor, when removing the dust-cap or changing the lens:



Figure 1: Hold camera like this while changing the lens/removing the dust cap of a camera

- Thread the lens onto the camera while holding the camera in this position. This will minimize the possibility of any contaminants falling on the glass surface.
- Always store cameras and lenses with dust-caps installed.

## Is it an impurity? – Identifying impurities

If you observe any image artefacts in your video preview of your Allied Vision camera you may have impurities either on the lens, filter/protection glass or, theoretically on the sensor protection glass, although every Allied Vision camera gets cleaned prior to sealing and shipment.

Impurities (dust, particles or fluids) on the sensor or optical components (*Figure 2: Image with tiny dust on the filter (left) and dust on the sensor (right)* on page 28) will appear as a dark area, patch or spot on the image and will remain fixed in the preview window while you rotate the camera over the target.

Do not confuse this with a pixel defect which will appear as a distinct point. It is crucial to differentiate between dust (e.g. flakes of skin, particles) and other dirt (e.g. liquids, fingerprints, grease). Particles can either rest loosely or can be more or less stuck to the optical surface.

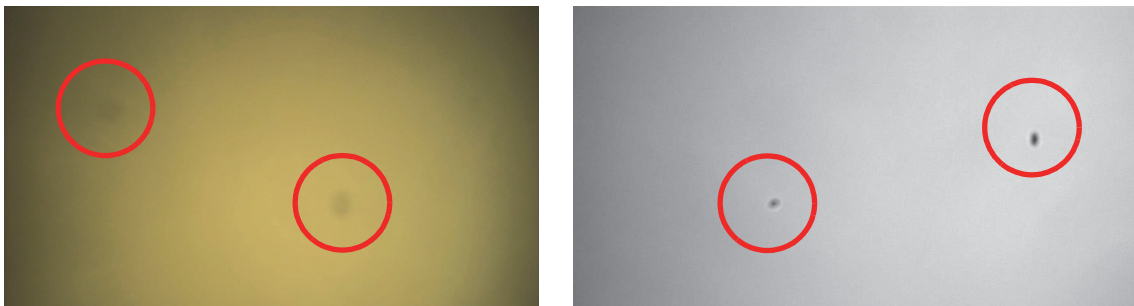

Figure 2: Image with tiny dust on the filter (left) and dust on the sensor (right)

## Where is the impurity? – Locating impurities

Before you dismount the lens you should find out if the impurity is on the filter, lens or sensor. Therefore you should view a uniform image (e.g. a white sheet of paper) with the camera. The affected optical surface is identified when a suspected optical component is moved and the dirt follows this movement.

1. If you move only the lens (not the camera) and the impurity moves as well, the impurity is on the lens.
2. If you move the IR cut filter/protection glass window and the impurity moves as well:

Please carefully remove the filter/protection glass (for certain camera models, indicated below, requiring a special tool which can be ordered under the following number: E9020001) and clean it on both sides using the techniques explained below.

Camera type	Tool to be used	Description
Oscar	1.3 mm hex key (Allen key) Allied Vision order number K 9020411	Loosen both countersunk screws. Remove chromatic flange: Take care, C-Mount adjustment spacers may fall out. Put them back carefully on chromatic flange and screw chromatic flange with adjustment spacers in camera.
Marlin	Allied Vision order number E9020001	<a href="#">Figure 3: Removing IR cut filter/protection glass using special tool (E9020001)</a> on page 30
Guppy	Pliers and leather	Carefully unscrew the knurled ring.
Pike	1.3 mm hex key (Allen key) Allied Vision order number K 9020411	Loosen both countersunk screws (looking in front of the lens the screws are on the <b>top (middle)</b> and on the <b>right side</b> of the housing). Remove chromatic flange: Take care, C-Mount adjustment spacers may fall out. Put them back carefully on chromatic flange and screw chromatic flange with adjustment spacers in camera.
Stingray	<ul style="list-style-type: none"> <li>Stingray cameras Rev. 1: see Guppy</li> <li>Stingray cameras Rev. 2 and 3: Allied Vision order number E9020001</li> </ul>	<ul style="list-style-type: none"> <li>Stingray cameras Rev. 1: see Guppy</li> <li>Stingray cameras Rev. 2/3: <a href="#">Figure 3: Removing IR cut filter/protection glass using special tool (E9020001)</a> on page 30</li> </ul> <div style="display: flex; justify-content: space-around; align-items: center;"> <div style="text-align: center;">  <p>Stingray Rev. 1</p> </div> <div style="text-align: center;">  <p>Stingray Rev. 2</p> </div> <div style="text-align: center;">  <p>Stingray Rev. 3</p> </div> </div>
Guppy PRO	Allied Vision order number E9020001	<ul style="list-style-type: none"> <li>Guppy PRO cameras: <a href="#">Figure 3: Removing IR cut filter/protection glass using special tool (E9020001)</a> on page 30</li> </ul> <div style="text-align: center;">  <p>Guppy PRO</p> </div>

Table 4: How to remove the filter/protection glass

Not all camera types have the design to remove the filter/protection glass. See Chapter [Changing filters safety instructions](#) on page 21.

**Note**

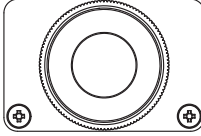
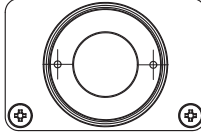
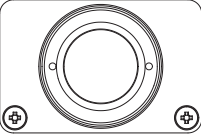
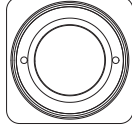

- Taking out the filter requires special care. The customer is **fully responsible** for all actions of changing/removing filter by himself.
- Ask your dealer to help you if you are not confident with the procedure.



Figure 3: Removing IR cut filter/protection glass using special tool (E9020001)

3. If the impurity is neither on the lens nor the IR cut filter/protection glass, it is probably on the sensor.

## Cleaning Instructions

Perform all cleaning operations (lenses, filter/protection glass, sensor in a **dust-free clean-room**. The optical components are very fragile so it is important to avoid touching them with your fingers or any hard material.

1. Unplug the camera from any power supply before cleaning.
2. Apply a small amount of optics cleaner (60% ethyl alcohol, 40% ether) to clean, new lens cleaning tissue.

Acceptable material includes medical-grade sterile optical cotton, or lens tissue that is chemically pure and free from silicones and other additives.

- **Do not** use cosmetic cotton.
- **Do not** use consumer eyeglass cleaning cloths pre-treated with silicon.



Figure 4: Medical-grade sterile optical cotton

The cotton or lens tissue should be moist, but not dripping. Please hold the camera away from your body to avoid falling particles like flakes from skin on the sensor. Hold the camera sensor diagonally upwards.

3. Wipe the glass surface with a spiral motion from the centre to the rim. Normally several spiral wipes are recommended. Wipe only on glass avoiding contact to metal surfaces, because microscopic dirt could be released and could cause scratches on the glass.



Figure 5: Sensor cleaning

4. When you've finished cleaning, examine the surface in a strong light. Take an out-of-focus picture of a flat, illuminated surface to see if any dirt or dust remains.
5. If dust spots remain, repeat this procedure using new clean lens tissue (as described above).

**Caution**



- Never wipe lenses with dry swabs or tissue - this causes scratches.
- Do not use any disposable cotton cosmetic swabs; they are not free from contamination.

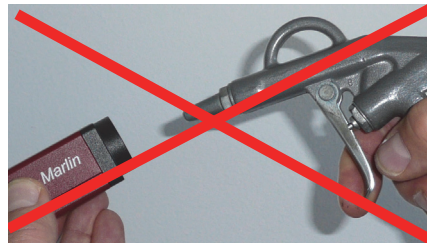

Figure 6: Don't use compressed air

6. If despite warnings you want to clean your camera with compressed air:

**Caution**



- Use an air blower/compressed air only if you are familiar with cleaning a camera with this instrument.
- **Compressed air may push dust into cameras and lenses.** Therefore keep the pressure at a moderate strength only:
  - The pressure at the tube should be less than 1 bar (15 psi)
  - operating distance: 5-30 cm

7. Please gently blow the impurities off with dust-filtered, oil-free air (< 1 bar). Using ionized air will help to remove any dirt stuck to the optical component because of static electricity.

**Note**

**If dust spots remain after cleaning twice, please contact your Allied Vision dealer.**





# Allied Vision 1394 cameras: installing hardware

This chapter describes the **hardware installation** of 1394a/b Allied Vision cameras, 1394 adapters (PC or laptop) and the necessary cabling.

**Note** For software/driver installation read the documentation of the corresponding software package.



If you connect an Allied Vision 1394 camera to your PC/laptop (before software/driver installation), the following window will appear (example Windows XP):



Figure 7: Window: Found New Hardware Wizard

You have two choices:

- If you want to use an **Allied Vision SoftwarePackage**, click **Cancel** to close the window. The necessary Allied Vision driver can be installed during the installation process of the selected Allied Vision software package.
- If you want to use your **own image processing software**, ask your image processing vendor what to do now.

## Hardware conditions

- Allied Vision IEEE 1394a or 1394b camera (1394a: Oscar, Marlin, Guppy; 1394b: Guppy PRO, Pike, Stingray) with corresponding lens
- 1394 cable
- PC or laptop with built-in IEEE 1394 interface
- IEEE 1394 adapter (OHCI) card for PCI bus or PCI Express bus or PC card or ExpressCard with IEEE 1394 port(s)

### Note

---

Allied Vision offers a wide range of IEEE 1394 adapters, both 1394a or 1394b for different requirements.



### www

---

For more information on accessories and for ordering, see:

<http://www.alliedvision.com/en/contact>



## FireWire hot-plug and screw-lock precautions

### Caution

---



#### Hot-plug precautions

- Although FireWire devices can **theoretically** be hot-plugged without powering down equipment, **we strongly recommend turning the computer power off, before connecting a digital camera** to it via a FireWire cable.
- **Static electricity or slight plug misalignment during insertion may short-circuit and damage components.**
- The physical ports **may be damaged by excessive ESD** (electrostatic discharge), when connected under powered conditions. It is good practice to ensure proper grounding of computer case and camera case to the same ground potential, before plugging the camera cable into the port of the computer. This ensures that no excessive difference of electrical potential exists between computer and camera.

#### Screw-lock precautions

- Also, all Allied Vision 1394b camera and cables have **industrial screw-lock fasteners**, to insure a tight electrical connection that is resistant to vibration and gravity.
- **We strongly recommend using only 1394b adapter cards with screw-locks.**

### www

---



For more information on cables and for ordering, see:

<http://www.alliedvision.com/en/contact>

## Overview hardware installation

- Install IEEE 1394 adapter (if PC or laptop does not have an IEEE 1394 port)
- Install Allied Vision software package and start the corresponding viewer provided with the Allied Vision SDK you have selected (see the corresponding SDK manual)
- Connect camera to PC or laptop and ensure that the camera is powered

### Note



Read the software manuals to get information on licensing, acquiring your first image with viewer and troubleshooting.

Only the viewer of FirePackage (SmartView) provides extended GUI control options to evaluate Allied Vision 1394 camera vendor-specific features.

### www



For more information on software see:

<http://www.alliedvision.com/en/support/software-downloads>

## Installing IEEE 1394 adapter

1. **PC:** Install the IEEE 1394 adapter according to the instructions you got from your adapter manufacturer.  
**Laptop:** Insert the IEEE 1394 PC Card into your laptop. Connect external power supply to the adapter to power the camera or power the camera via Hirose connector.
2. Windows XP/ Windows Vista / Windows 7 will detect the hardware automatically and installs a Windows 1394 driver.

## Connecting camera to PC or laptop

1. Shut down your PC or laptop and **turn computer power off.**

**Caution**

- **Do not touch the shield of the camera cable** connected to a computer and the ground terminal of the lines at the same time.
- If you are charged: before touching the shield of the camera cable, make sure to discharge first (by touching the ground terminal of the lines).
- **Use only DC power supplies with insulated cases.** These are identified by having only **two** power connectors.
- If you feel uncomfortable with the previous advice or if you have no knowledge about the connectivity of an installation, **we strongly recommend powering down all systems before connecting or disconnecting a camera.**

**Caution****Hot-plug precautions**

- Although FireWire devices can **theoretically** be hot-plugged without powering down equipment, **we strongly recommend turning the computer power off, before connecting a digital camera** to it via a FireWire cable.
- **Static electricity or slight plug misalignment during insertion may short-circuit and damage components.**
- The physical ports **may be damaged by excessive ESD** (electrostatic discharge), when connected under powered conditions. It is good practice to ensure proper grounding of computer case and camera case to the same ground potential, before plugging the camera cable into the port of the computer. This ensures that no excessive difference of electrical potential exists between computer and camera.

**Screw-lock / Latching precautions**

- We strongly recommend using only 1394a cables with **latch connectors** / 1394b cables with **industrial screw-lock fasteners**, to insure a tight electrical connection that is resistant to vibration and gravity.
- **We strongly recommend using only 1394b adapter cards with screw-locks.**

2. Insert one end of the FireWire cable into your 1394 adapter or 1394 PC card.
3. Insert the other end of the FireWire cable into your camera.
4. Check that the camera is powered (green LED ON).

## Camera interfaces

Each Allied Vision 1394 camera has the following interfaces:

- The 12-pin camera I/O connector (Guppy: 8-pin) provides different control inputs and output lines.
- One or two IEEE 1394a or 1394b connectors with screw lock mechanism provide access to the IEEE 1394 bus and thus makes it possible to control the camera and output frames.
  - Oscar, Marlin and Guppy provide one 1394a connector.
  - Pike and Stingray provide 2x 1394b connectors.
  - Guppy PRO provides one 1394b connector.

**Note** For information on status LEDs see the Technical Manuals.

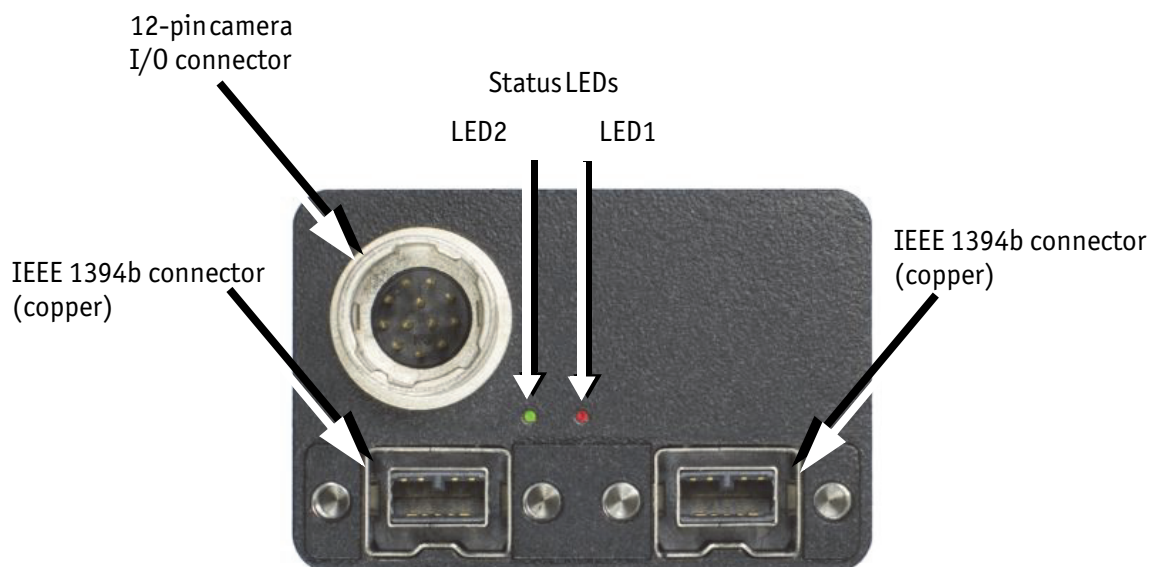

Figure 8: Example: Rear view of Stingray camera (2x 1394b copper)





Oscar	Marlin	Guppy
		
HIROSE and 1x 1394a	HIROSE and 1x 1394a	HIROSE and 1x 1394a
Pike	Stingray	Guppy PRO
		
HIROSE and 2x 1394b	HIROSE and 2x 1394b	HIROSE and 1x 1394b

Table 5: Rear view of Allied Vision 1394 cameras (HIROSE and 1394 copper)

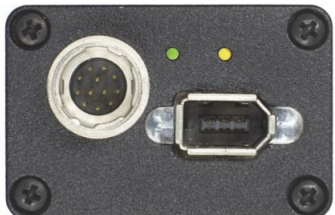

Pike fiber	Stingray fiber
	
HIROSE and 1x 1394b GOF, 1x 1394b copper GOF (marked with red line): 2x optical fiber on LCLC, dust cover off	HIROSE and 1x 1394b GOF, 1x 1394b copper GOF (marked with red line): 2x optical fiber on LCLC, dust cover off

Table 6: Rear view of Allied Vision 1394 cameras (HIROSE and 1394b GOF/copper)

## IEEE 1394a port pin assignment (Oscar, Marlin, Guppy)

The IEEE 1394a connector is designed for industrial use and has the following pin assignment as per specification:

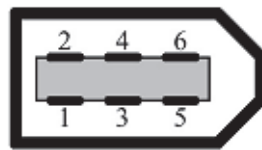

Pin	Signal
1	Cable power
2	Cable GND
3	TPB-
4	TPB+
5	TPA-
6	TPA+

Figure 9: IEEE 1394a connector

### Note



Cables with latching connectors on one or both sides can be used and are available with various lengths from 0.5 m to 17.5 m. Ask your local dealer for more details.

### www



For more information on cables and for ordering, see:  
<http://www.alliedvision.com/en/contact>



### Board level camera (Guppy): IEEE 1394a port pin assignment

Board level Guppies have two 1394a ports to allow daisy chaining of cameras.

The IEEE 1394a pin header (2.54 mm connector: FireWire connector 1) is designed for adding a 1394a adapter cable of:

e.g. IEEE 1394 6 PIN - PANEL F TO 2X5 F (Allied Vision#: K1200155)

It has the following pin assignment:

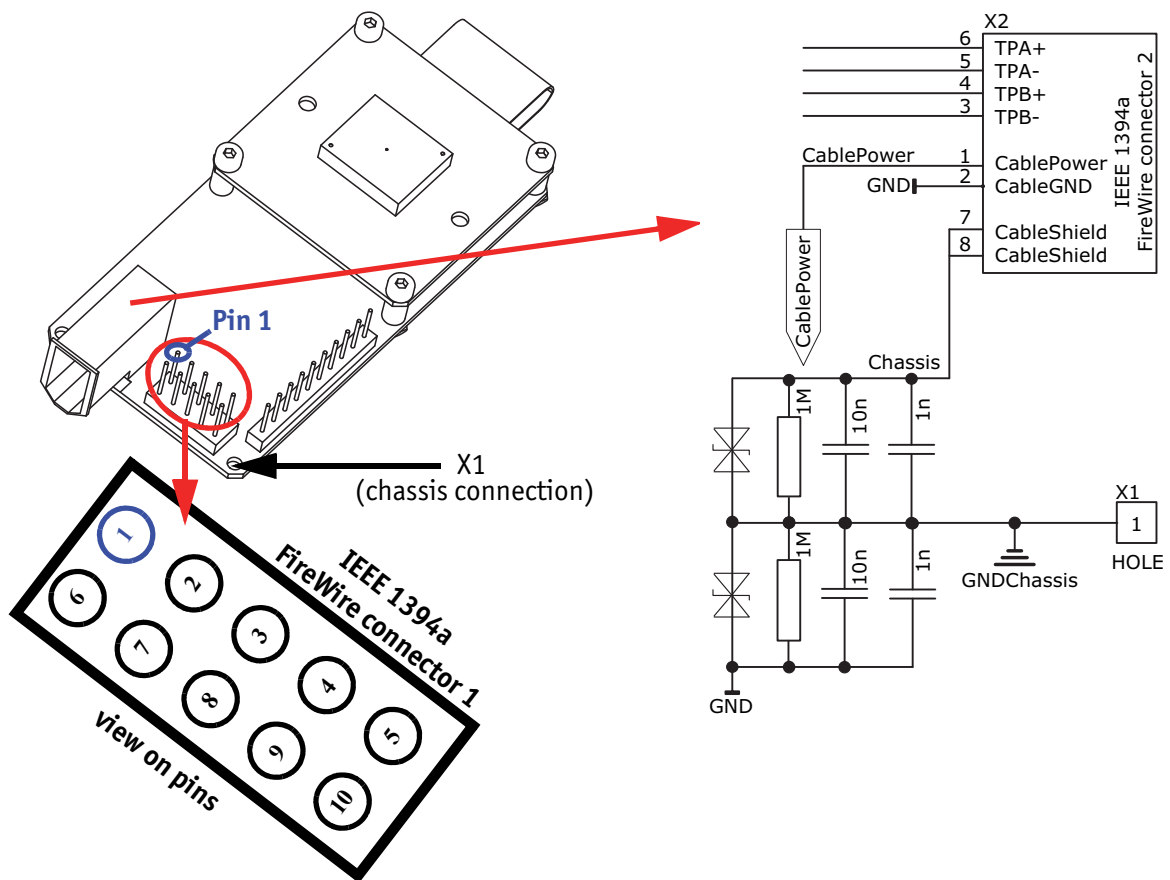

Figure 10: Board level camera (Guppy): IEEE 1394 FireWire connector 1 (view on pins)

Signal	Pin	Pin	Signal
TPA+	6	1	TPA-
-	7	2	GND
TPB+	8	3	TPB-
-	9	4	Cable power
-	10	5	Cable shield

Table 7: Board level camera (Guppy): IEEE 1394a pin assignment (FireWire connector 1)

## IEEE 1394b port pin assignment (Guppy PRO, Pike, Stingray)

The IEEE 1394b connector is designed for industrial use and has the following pin assignment as per specification:

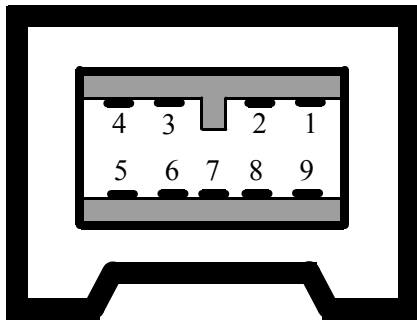

Pin	Signal
1	TPB-
2	TPB+
3	TPA-
4	TPA+
5	TPA (Reference ground)
6	VG (GND)
7	N.C.
8	VP (Power, VCC)
9	TPB (Reference ground)

Figure 11: IEEE 1394b connector

### Note



- Both IEEE 1394b connectors with screw lock mechanism provide access to the IEEE 1394 bus and thus makes it possible to control the camera and output frames. Connect the camera by using either of the connectors. The other connector can be used to daisy chain a second camera.
- Cables with latching connectors on one or both sides can be used. Ask your local dealer for more details.

### www



For more information on cables and for ordering, see:

<http://www.alliedvision.com/en/contact>

## Board level camera (Stingray): IEEE 1394b port pin assignment

Board level Stingray cameras have two 1394b ports to allow daisy chaining of cameras.

They have the same pin assignment as the Stingray housing cameras.

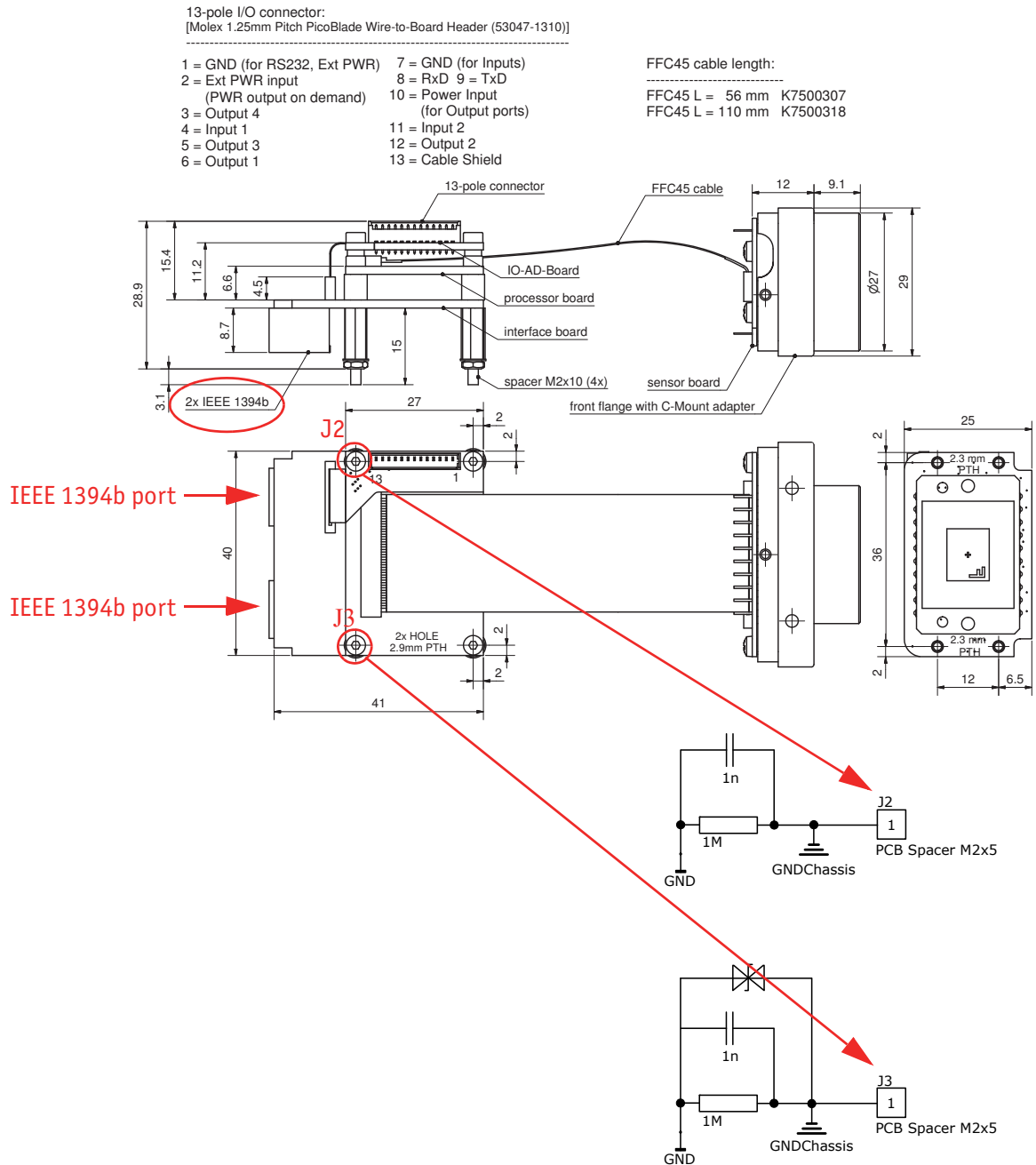

Figure 12: Board level camera (Stingray): two IEEE 1394b FireWire connectors

## Pike/Stingray fiber infos and cautions

All Pike and Stingray cameras are also available as **fiber version** with **1 x GOF connector and 1x copper connector**.

The GOF connector is of the following type: **2 x optical fiber on LCLC**

The GOF transmission uses **MMF (multi-mode fiber at 850 nm)**.

Connect the camera by using either of the connectors. The other connector can be used to daisy chain a second camera. In case of long distances between PC and camera, use the GOF connector for the long distance and the IEEE 1394b connector for optional daisy-chaining. Please ensure that you use a GOF hub on the PC side for reconversion from GOF to copper (order number E3000074 (with mounting plate) or E3000084 (with top-hat rail)). Alternatively use PCI or PCI-Express cards with built in GOF port. Ask your dealer for availability and details of these cards.

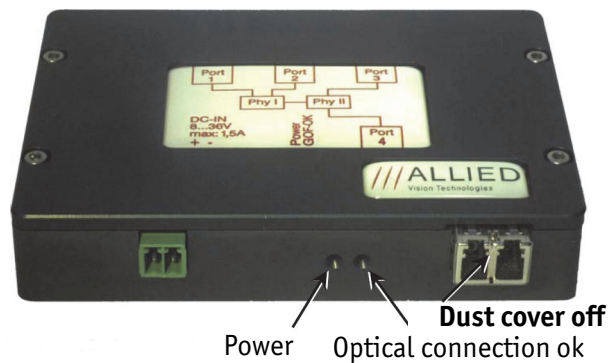

Figure 13: GOF hub



Figure 14: PCI Express card (1 x GOF, 2 x 1394 bilingual)

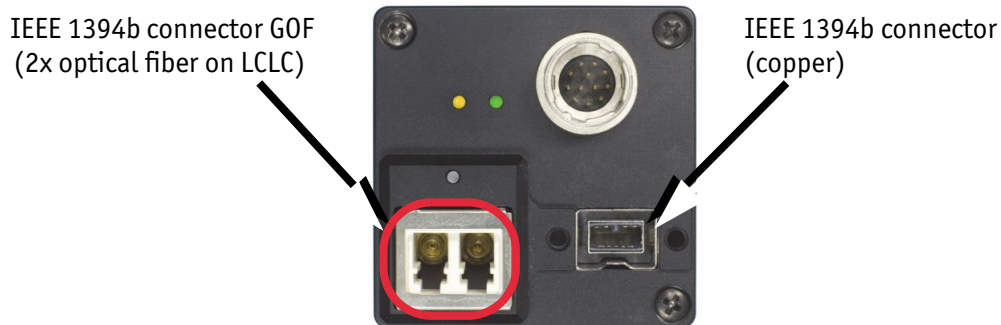

Figure 15: Rear view of Pike camera (1394b: 1 x GOF, 1 x copper) (Stingray similar)

**Caution**



**Special warning for all Pike/Stingray models with GOF connectors:**

**GOF connectors are very sensitive. Any dust or dirt may cause damage.**

- **Always keep the GOF connector and optical fiber plug clean.**
- If GOF connection is not in use, **keep GOF dust cover on the GOF connector.**
- **Reduce mating cycles to a minimum** to prevent abrasion.
- Please note that optical fiber cables have a **very limited deflection curve radius.**

## Camera I/O connectors (12 pin) order numbers and cables: Guppy PRO, Stingray, Pike, Marlin, Oscar

The 12-pin camera I/O connector (Guppy PRO, Stingray, Pike, Marlin, Oscar) is also designed for industrial use and, in addition to providing access to the inputs and outputs on the camera, it also provides a serial interface for e.g. the firmware update.

The connector is available in straight and angled version.

**Note** Allied Vision supplies suitable I/O cables of different lengths (up to 10 m) as shown below.



**www**



For more information on cables and for ordering, see:  
<http://www.alliedvision.com/en/contact>

**Note** For pinning of the I/O connectors as viewed in pin direction see:



- Chapter [Stingray camera I/O connector pin assignment](#) on page 48
- Chapter [Pike camera I/O connector pin assignment](#) on page 55
- Chapter [Guppy PRO camera I/O connector pin assignment](#) on page 63
- Chapter [Marlin camera I/O connector pin assignment](#) on page 76
- Chapter [Oscar camera I/O connector pin assignment](#) on page 81

## Camera I/O connectors (8 pin) order numbers and cables: Guppy

The 8-pin camera I/O connector (only Guppy cameras) is designed for industrial use.

It provides:

- access to the inputs and outputs on the camera
- a serial interface

Allied Vision also supplies various I/O cables of different lengths.

**www**



**For more information on cables and for ordering, see:**

<http://www.alliedvision.com/en/contact>

**Note**



**For pinning of the I/O connectors as viewed in pin direction see Chapter [Guppy camera I/O connector pin assignment](#) on page 69.**

## Stingray camera interfaces

### Stingray camera I/O connector pin assignment

(For board level see Chapter [Stingray board level camera: I/O pin assignment](#) on page 54)

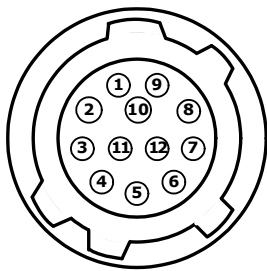

Pin	Signal	Direction	Level	Description
1	External GND		GND for RS232 and ext. power	External Ground for RS232 and external power
2	External Power		+8 ... +36 V DC	Power supply
3	Camera Out 4	Out	Open emitter	Camera Output 4 (GPOut4) default: -
4	Camera In 1	In	$U_{in}(high) = 3 V...24 V$ $U_{in}(low) = 0 V...1.5 V$	Camera Input 1 (GPIIn1) default: Trigger
5	Camera Out 3	Out	Open emitter	Camera Output 3 (GPOut3) default: Busy
6	Camera Out 1	Out	Open emitter	Camera Output 1 (GPOut1) default: IntEna
7	Camera In GND	In	Common GND for inputs	Camera Common Input Ground (In GND)
8	RxD RS232	In	RS232	Terminal Receive Data
9	TxD RS232	Out	RS232	Terminal Transmit Data
10	Camera Out Power	In	Common VCC for outputs max. 36 V DC	External Power for digital outputs (OutVCC)
11	Camera In 2	In	$U_{in}(high) = 3 V...24 V$ $U_{in}(low) = 0 V...1.5 V$	Camera Input 2 (GPIIn2) default: -
12	Camera Out 2	Out	Open emitter	Camera Output 2 (GPOut2) default: Follow CameraIn2

Figure 16: Stingray: Camera I/O connector pin assignment



## Stingray input description

### Stingray input block diagram

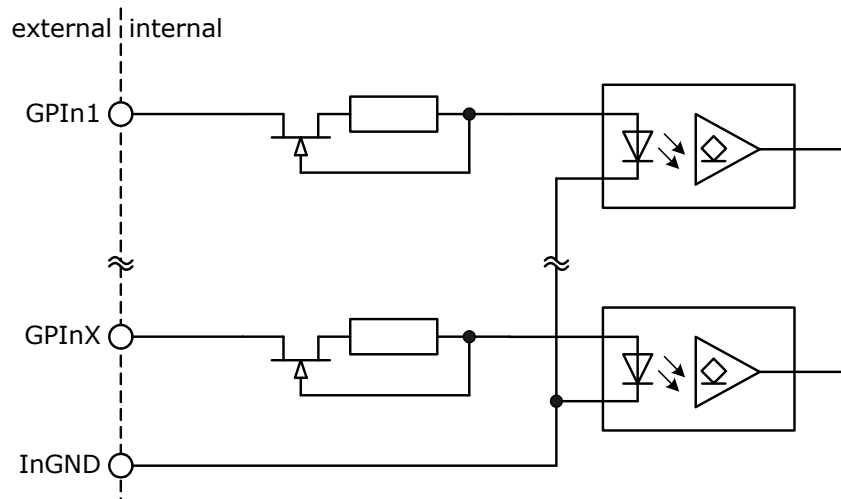

Figure 17: Stingray input block diagram

The inputs can be connected directly up to max. +24 V. If you want to use voltages from +24 V...+36 V you have to place an external resistor of 1.5 k $\Omega$  (1/10 watt) in series with your voltage source.

#### Caution **Stingray**



- Voltages above +24 V (without external resistor) may damage the camera.
- Voltages above +36 V (with an external resistor of 1.5 k $\Omega$ ) may damage the camera.

Parameter	Value
$U_{in}$ (low)	0 V ... 1.5 V
$U_{in}$ (high)	3 V ... 24 V
Current (constant current source within the camera)	8 mA
Flux voltage of the LED (@ 10 mA)	1.5 V

Table 8: Stingray input parameters

**Stingray delay and minimum pulse width**

The **cycle delay** for all Stingray cameras is:

$t_{pdLH} < 1.0 \mu s$  and  $t_{pdHL} < 1.5 \mu s$

The **minimum pulse width** for all Stingray cameras is:

$t_p > 1.6 \mu s$

**Test conditions**

The input signal was driven with 12 V and a 2.2 k $\Omega$  pull down resistor to GND.

## Stingray output description

### Stingray block diagram

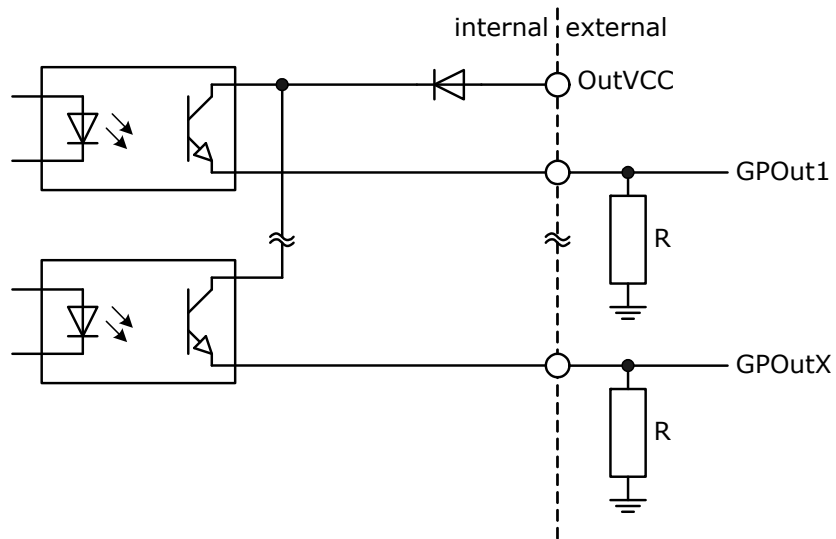

Figure 18: Stingray: output block diagram

**Caution**



**Stingray**

- Max. 15 mA per output
- OutVCC > 36 V may damage the camera

OutVCC	Resistor value	
5 V	1 kΩ	~ 5 mA load recommended
12 V	2.4 kΩ	
24 V	4.7 kΩ	
5 V	0.33 kΩ	~ 15 mA load absolute maximum
12 V	0.82 kΩ	
24 V	1.6 kΩ	

Figure 19: Stingray: OutVCC and external resistor

**Stingray delay**

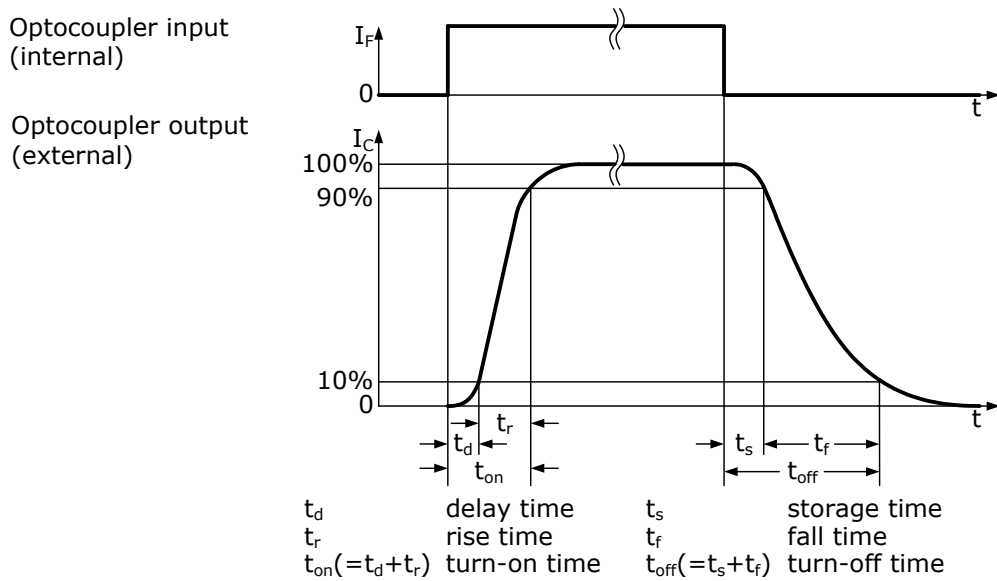

Figure 20: Stingray output switching times

For all Stingray models:

Parameter and value	
$t_d \approx 1 \mu s$	$t_s \approx 26 \mu s$
$t_r \approx 1 \mu s$	$t_f \approx 21 \mu s$
$t_{on} = t_d + t_r \approx 2 \mu s$	$t_{off} = t_s + t_f \approx 47 \mu s$ ( $t_{off}$ can deviate by $\pm 5 \mu s$ )

Table 9: Parameters for Stingray

**Test conditions**

Camera: Format\_7 Mode\_0, Mono8, S800, extended shutter set to minimum

Output: external 2.4 k $\Omega$  resistor to GND, power input for output ports set to 12 V

## Stingray data

The RS232 data interface has a typical output voltage from  $\pm 4.2$  V.

## Stingray power

In accordance to IEEE 1394b specification the power supply (+8 V ... +36 V) should deliver a current of at least 1.5 A.

### Note

---



**If using daisy chain the camera has to supply further components with also 1.5 A.**

**In such cases your power supply should be able to deliver 3.0 A.**

## Stingray board level camera: I/O pin assignment

The following diagram shows the 13-pole I/O pin connector of a Stingray board level camera:

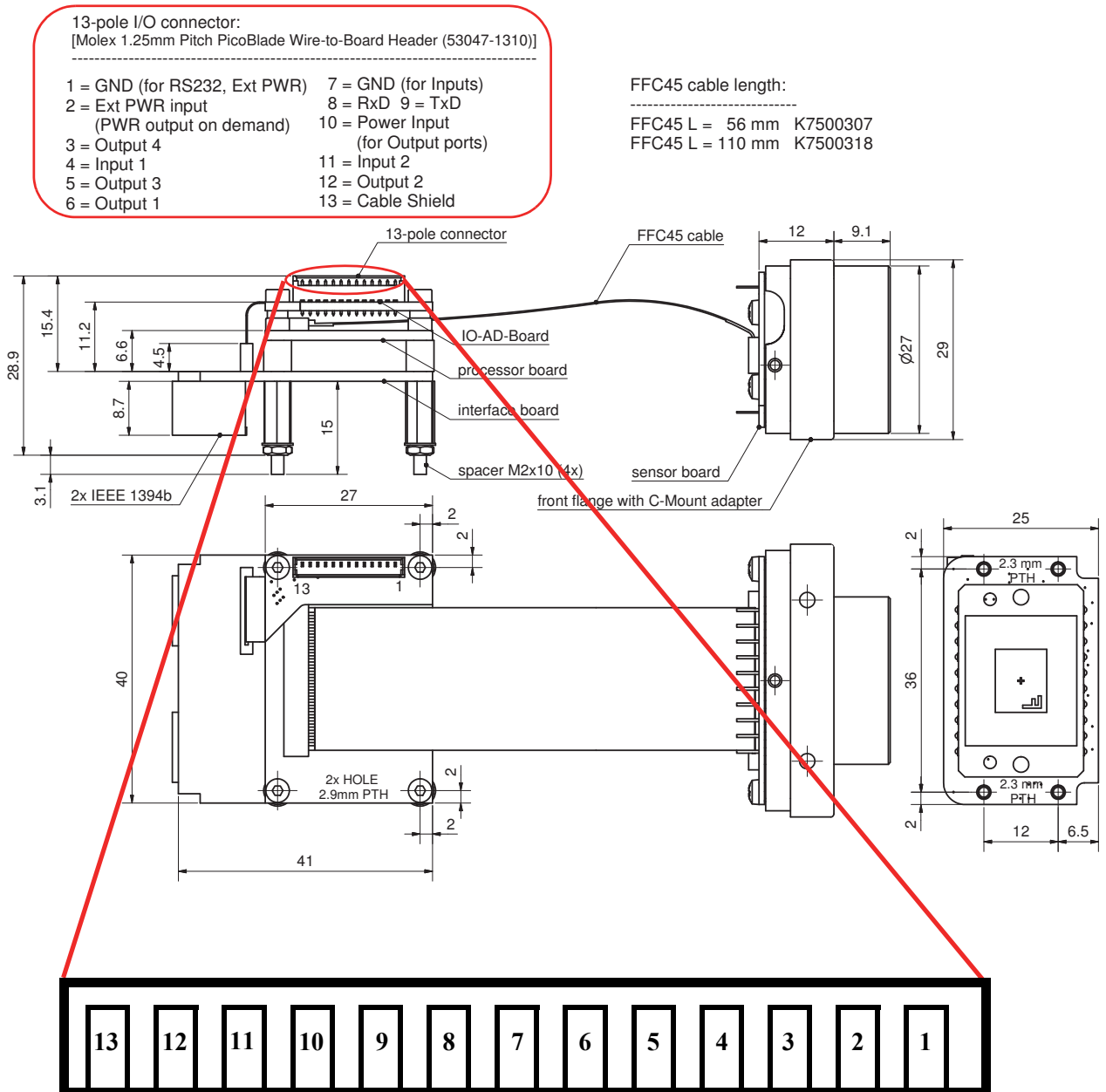
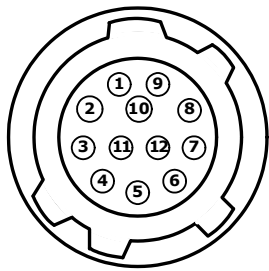

Figure 21: Stingray board level camera: I/O pin assignment

## Pike camera interfaces

### Pike camera I/O connector pin assignment



Pin	Signal	Direction	Level	Description
1	External GND		GND for RS232 and ext. power	External Ground for RS232 and external power
2	External Power		+8 ... +36 V DC	Power supply
3	Camera Out 4	Out	Open emitter	Camera Output 4 (GPOut4) default: -
4	Camera In 1	In	$U_{in}^*$ (high) = 3 V... $U_{inVCC}$ $U_{in}$ (low) = 0 V...0.8 V	Camera Input 1 (GPIn1) default: Trigger
5	Camera Out 3	Out	Open emitter	Camera Output 3 (GPOut3) default: Busy
6	Camera Out 1	Out	Open emitter	Camera Output 1 (GPOut1) default: IntEna
7	Camera In GND	In	Common GND for inputs	Camera Common Input Ground (In GND)
8	RxD RS232	In	RS232	Terminal Receive Data
9	TxD RS232	Out	RS232	Terminal Transmit Data
10	Camera Out Power	In	Common VCC for outputs max. 36 V DC	External Power for digital outputs (OutVCC)
11	Camera In 2	In	$U_{in}^*$ (high) = 3 V... $U_{inVCC}$ $U_{in}$ (low) = 0 V...0.8 V	Camera Input 2 (GPIn2) default: -
12	Camera Out 2	Out	Open emitter	Camera Output 2 (GPOut2) default: Follow CameraIn2

\*min. 5 mA input current;  $U_{in}$  depends on input current.

Figure 22: Pike: Camera I/O connector pin assignment

### Pike input description (not Pike F-505)

(for Pike F-505 see Chapter [Input description of Pike F-505](#) on page 58)

#### Pike input block diagram

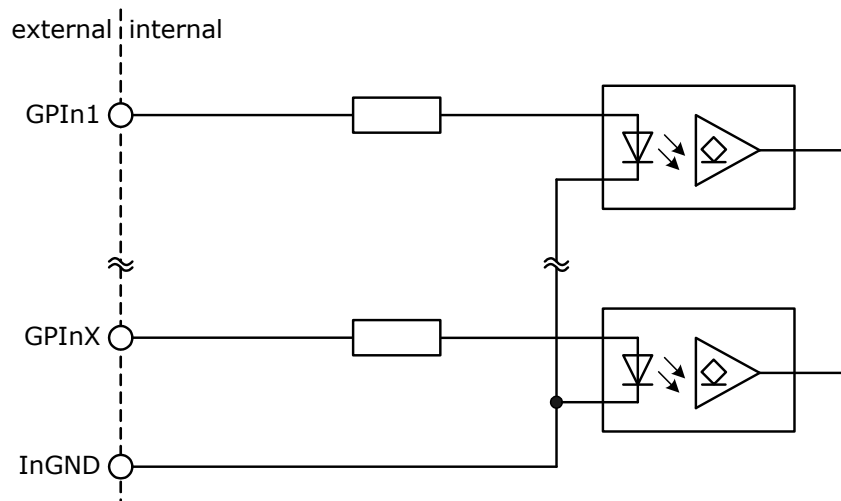

Figure 23: Pike input block diagram

The inputs can be connected directly to +5 V. If a higher voltage is used, an external resistor must be placed in series.

**Caution**

**Pike**

**Voltages above +36 V may damage the camera.**



Used input voltage ( $U_{inVCC}$ )	External series resistor
5 V	none
12 V	0.82 k $\Omega$
24 V	2.2 k $\Omega$
36 V	3.3 k $\Omega$

Table 10: Pike: external resistors for voltages higher than 5 V



Parameter	Value
Initial on-current	5 mA
Flux voltage of the LED (@ 10 mA)	1.5 V
Maximum off-current	0.25 mA
Maximum input current	15 mA

Table 11: Pike: input parameters

### **Pike delay and minimum pulse width**

The **cycle delay** for all Pike cameras (except Pike F-505) is:  
 $t_{pdLH} < 2.2 \mu s$  and  $t_{pdHL} < 2.9 \mu s$

The **minimum pulse width** for all Pike cameras (inclusive Pike F-505) is:  
 $t_p > 2.0 \mu s$

### **Test conditions**

The input signal was driven with 12 V and a 2.2 k $\Omega$  pull down resistor to GND.

## Input description of Pike F-505

Pike F-505 has a different input wiring compared to the other Pike models. The inputs of Pike F-505 are the same as the inputs of Stingray.

### Pike F-505 input block diagram

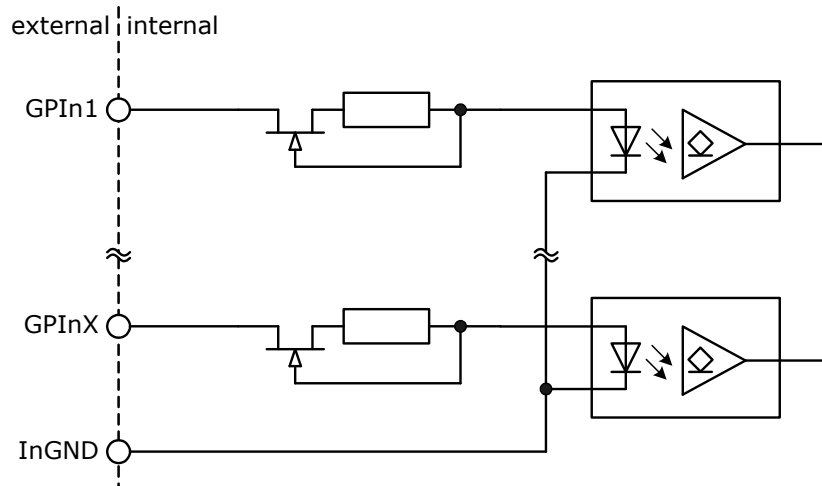

Figure 24: Pike F-505 input block diagram

The inputs can be connected directly up to max. +24 V. If you want to use voltages from +24 V...+36 V you have to place an external resistor of 1.5 k $\Omega$  (1/10 watt) in series with your voltage source.

#### **Caution** Pike F-505



- Voltages above +24 V (without external resistor) may damage the camera.
- Voltages above +36 V (with an external resistor of 1.5 k $\Omega$ ) may damage the camera.

Parameter	Value
$U_{in}$ (low)	0 V ... 1.5 V
$U_{in}$ (high)	3 V ... 24 V
Current (constant current source within the camera)	8 mA
Flux voltage of the LED (@ 10 mA)	1.5 V

Table 12: Stingray input parameters

**Pike F-505 delay and minimum pulse width**

The **cycle delay** for the Pike F-505 is:

$t_{pdLH} < 2.2 \mu s$  and  $t_{pdHL} < 2.8 \mu s$

The **minimum pulse width** for the Pike F-505 is:

$t_p > 2.0 \mu s$

**Pike F-505 test conditions**

The input signal was driven with 12 V and a 2.2 k $\Omega$  pull down resistor to GND.

## Pike output description

### Pike output block diagram

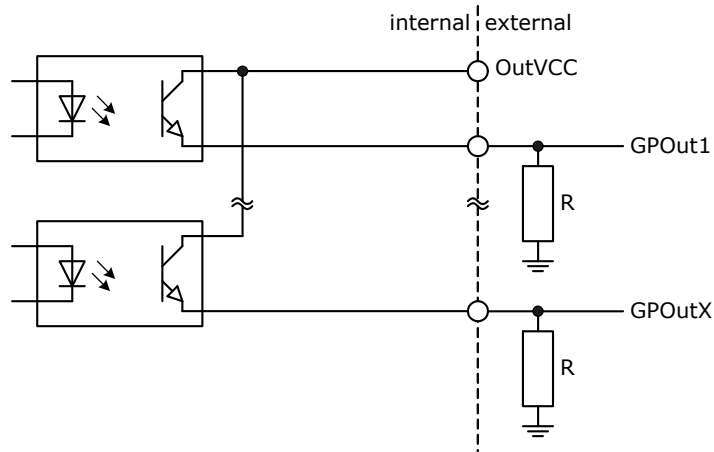

Figure 25: Pike: output block diagram

#### Caution



#### Pike

- Max. 20 mA per output
- OutVCC > 36 V may damage the camera.

OutVCC	Resistor value	
5 V	1 kΩ	~ 5 mA load recommended
12 V	2.4 kΩ	
24 V	4.7 kΩ	
5 V	0.27 kΩ	~ 20 mA load absolute maximum
12 V	0.62 kΩ	
24 V	1.2 kΩ	

Figure 26: Pike: OutVCC and external resistor

**Pike delay**

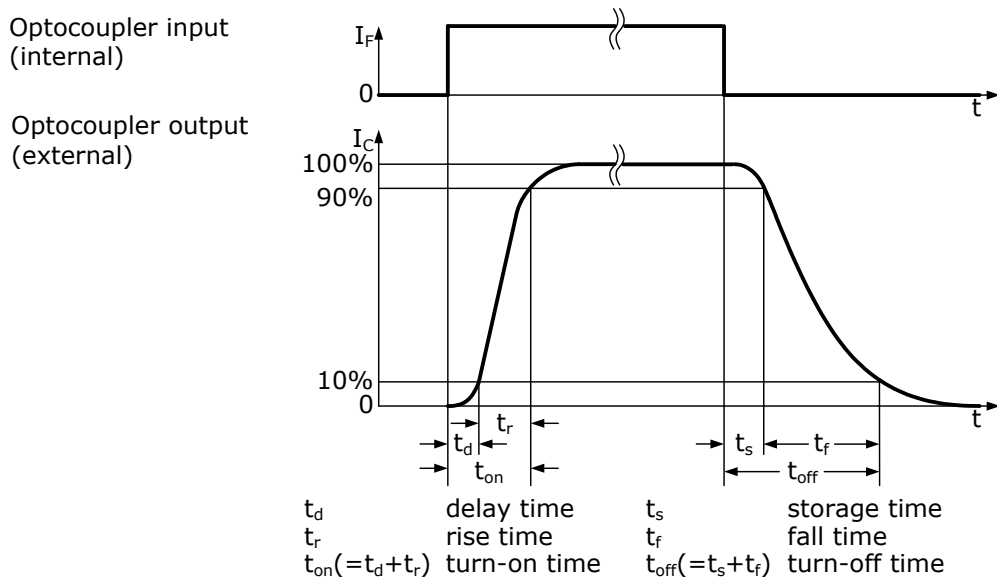

Figure 27: Pike output switching times

For all Pike models:

Parameter and value	
$t_d \approx 1 \mu s$	$t_s \approx 30 \mu s$
$t_r \approx 1 \mu s$	$t_f \approx 25 \mu s$
$t_{on} = t_d + t_r \approx 2 \mu s$	$t_{off} = t_s + t_f \approx 55 \mu s$ ( $t_{off}$ can deviate by $\pm 5 \mu s$ )

Table 13: Parameters for Pike

**Test conditions**

Camera: Format\_7 Mode\_0, Mono8, S800, extended shutter set to minimum

Output: external 2.4 k $\Omega$  resistor to GND, power input for output ports set to 12 V

## Pike data

The RS232 data interface has a typical output voltage from  $\pm 4.2$  V.

## Pike power

In accordance to IEEE 1394b specification the power supply (+8 V...+36 V) should deliver a current of at least 1.5 A.

### Note

---



**If using daisy chain the camera has to supply further components with also 1.5 A.**

**In such cases your power supply should be able to deliver 3.0 A.**

## Guppy PRO camera interfaces

### Guppy PRO camera I/O connector pin assignment

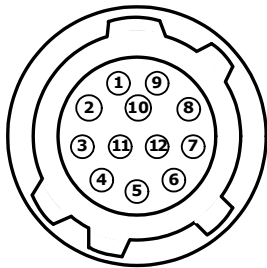

Pin	Signal	Direction	Level	Description
1	External GND		GND for ext. power	External Ground for external power
2	External Power		+8 ... +36 V DC	Power supply
3	---	---	---	---
4	Camera In 1	In	$U_{in}(high) = 3 V...24 V$ $U_{in}(low) = 0 V...1.5 V$	Camera Input 1 (GPIIn1) default: Trigger
5	Camera Out 3	Out	Open emitter	Camera Output 3 (GPOut3) default: Busy
6	Camera Out 1	Out	Open emitter	Camera Output 1 (GPOut1) default: IntEna
7	Camera In GND	In	Common GND for inputs	Camera Common Input Ground (In GND)
8	---	---	---	---
9	---	---	---	---
10	Camera Out Power	In	Common VCC for outputs max. 36 V DC	External Power for digital outputs (OutVCC)
11	---	---	---	---
12	Camera Out 2	Out	Open emitter	Camera Output 2 (GPOut2) default: Off

Figure 28: Guppy PRO: Camera I/O connector pin assignment

## Guppy PRO input description

### Guppy PRO input block diagram

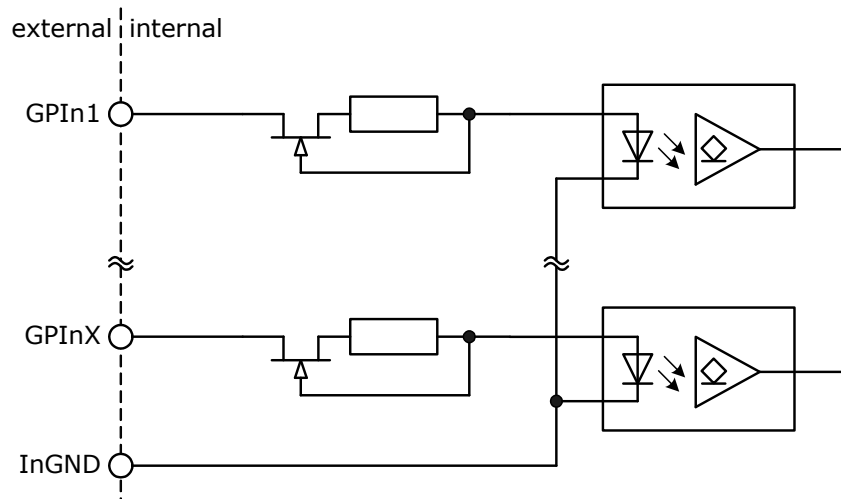

Figure 29: Guppy PRO input block diagram

The inputs can be connected directly up to max. +24 V. If you want to use voltages from +24 V... +36 V you have to place an external resistor of 1.5 k $\Omega$  (1/10 watt) in series with your voltage source.

**Caution**



**Guppy PRO**

- Voltages above +24 V (without external resistor) may damage the camera.
- Voltages above +36 V (with an external resistor of 1.5 k $\Omega$ ) may damage the camera.

Parameter	Value
U <sub>in</sub> (low)	0 V ... 1.5 V
U <sub>in</sub> (high)	3 V ... 24 V
Current (constant current source within the camera)	8 mA
Flux voltage of the LED (@ 10 mA)	1.5 V

Table 14: Guppy PRO input parameters



**Guppy PRO delay and minimum pulse width**

The **cycle delay** for all Guppy PRO cameras is:

$t_{pdLH} < 1.0 \mu s$  and  $t_{pdHL} < 1.5 \mu s$

The **minimum pulse width** for all Guppy PRO cameras is:

$t_p > 1.6 \mu s$

**Test conditions**

The input signal was driven with 12 V and a 2.2 k $\Omega$  pull down resistor to GND.

## Guppy PRO output description

### Guppy PRO block diagram

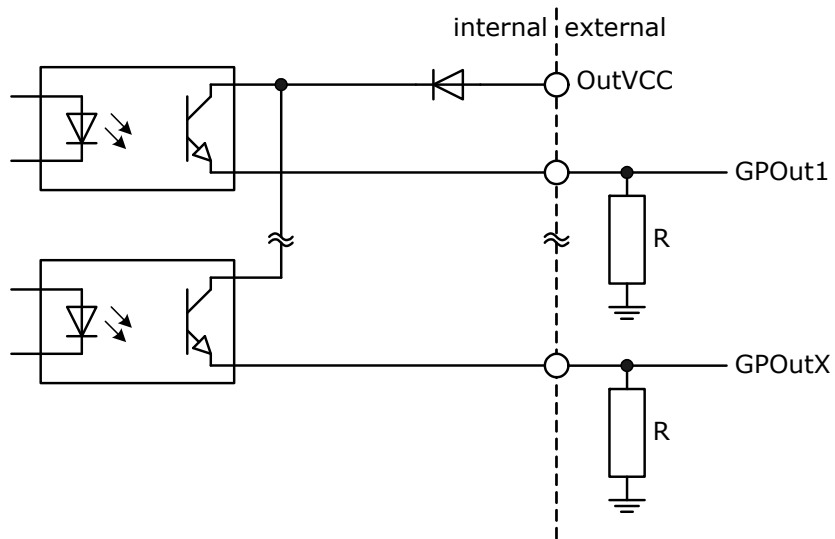

Figure 30: Guppy PRO: output block diagram

#### Caution



#### Guppy PRO

- Max. 15 mA per output
- OutVCC > 36 V may damage the camera.

OutVCC	Resistor value	
5 V	1 kΩ	~ 5 mA load recommended
12 V	2.4 kΩ	
24 V	4.7 kΩ	
5 V	0.33 kΩ	~ 15 mA load absolute maximum
12 V	0.82 kΩ	
24 V	1.6 kΩ	

Figure 31: Guppy PRO: OutVCC and external resistor

**Note**

---



**Guppy PRO F-503:**

**IntEna is high, when all pixels are integrated simultaneously.**

**⇒ Using IntEna with electronic rolling shutter and global reset release shutter: see Guppy PRO Technical Manual, Chapter *Trigger modi*.**

**Guppy PRO delay**

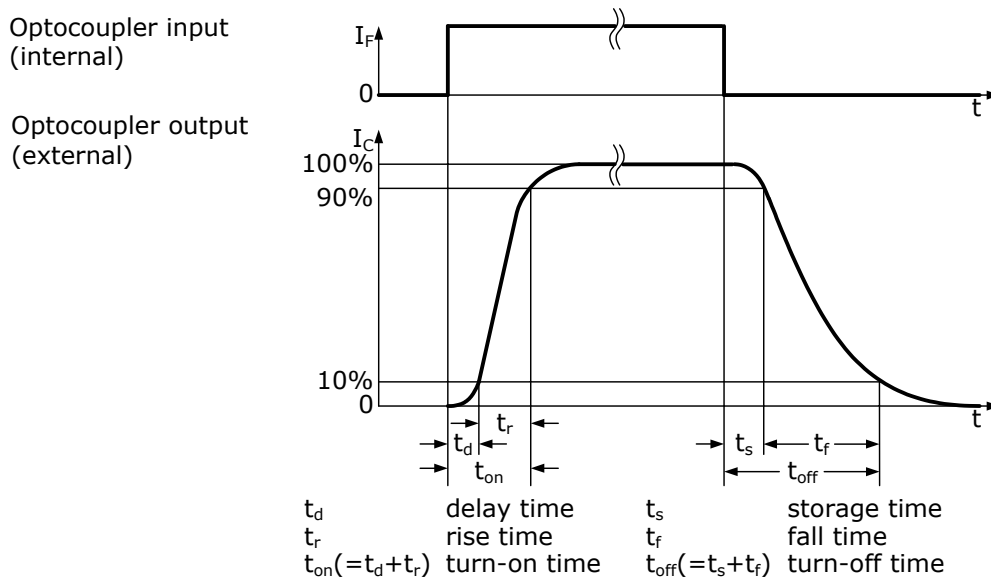

Figure 32: Guppy PRO output switching times

For all Guppy PRO models:

Parameter and value	
$t_d \approx 1 \mu s$	$t_s \approx 26 \mu s$
$t_r \approx 1 \mu s$	$t_f \approx 21 \mu s$
$t_{on} = t_d + t_r \approx 2 \mu s$	$t_{off} = t_s + t_f \approx 47 \mu s$ ( $t_{off}$ can deviate by $\pm 5 \mu s$ )

Table 15: Parameters for Guppy PRO

**Test conditions**

Camera: Format\_7 Mode\_0, Mono8, S800, extended shutter set to minimum  
 Output: external 2.4 k $\Omega$  resistor to GND, power input for output ports set to 12 V

**Guppy PRO data**

Currently RS232 data interface is not implemented.

**Guppy PRO power**

In accordance to IEEE 1394b specification the power supply (+8 V ... +36 V) should deliver a current of at least 1.5 A.

## Guppy camera interfaces

### Guppy camera I/O connector pin assignment

#### Guppy (housing)

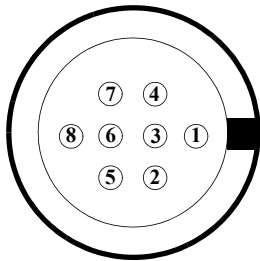

Pin	Signal	Direction	Level	Description
1	Camera Out 1	Out	$U_{out}(high) = 2.4 V \dots 5 V$ $U_{out}(low) = 0 V \dots 0.4 V$	Camera Output 1 (GPOut1) default: IntEna
2	Camera Out 2	Out	$U_{out}(high) = 2.4 V \dots 5 V$ $U_{out}(low) = 0 V \dots 0.4 V$	Camera Output 2 (GPOut2) default: -
3	Camera Out 3	Out	$U_{out}(high) = 2.4 V \dots 5 V$ $U_{out}(low) = 0 V \dots 0.4 V$	Camera Output 3 (GPOut3) default: Busy
4	Camera In 1	In	$U_{in}(high) = 3.8 V \dots 5 V$ $U_{in}(low) = 0 V \dots 1 V$	Camera Input 1 (GPIIn1) default: Trigger
5	RxD RS232	In	RS232	Terminal Receive Data
6	TxD RS232	Out	RS232	Terminal Transmit Data
7	External Power		+8 ... +36 V DC	Power supply
8	External GND		GND for RS232, GPIOs and ext. power	External Ground for RS232, GPIOs and external power

Figure 33: Guppy (housing): Camera I/O connector pin assignment

### Guppy (board level)

The following diagram shows the I/O pin header (2.54 mm connector) of a board level camera as viewed in pin direction:

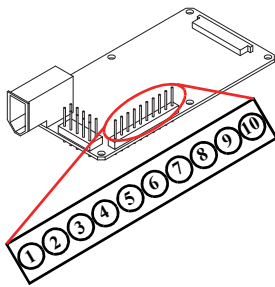

Pin	Signal	Direction	Level	Description
1	External GND		GND for RS232, GPIOs and ext. power	External Ground for RS232, GPIOs and external power
2	External Power		+8...+36 V DC	Power supply
3	GND			
4	TxD RS232	Out	RS232	Terminal Transmit Data
5	RxD RS232	In	RS232	Terminal Receive Data
6	GND			
7	Camera In/Out 4	In/Out	$U_{in}(high) = 2 V...5 V$ $U_{in}(low) = 0 V...0.8 V$ $U_{out}(high) = 2.4 V...5 V$ $U_{out}(low) = 0 V...0.4 V$	Camera Input/Output 4 (GPIInOut4) default: -
8	Camera In/Out 3	In/Out		Camera Input/Output 3 (GPIInOut3) default: -
9	Camera In/Out 2	In/Out		Camera Input/Output 2 (GPIInOut2) default: -
10	Camera In/Out 1	In/Out		Camera Input/Output 1 (GPIInOut1) default: -

Figure 34: Guppy (board level): Camera I/O connector pin assignment

## Guppy input description

### Guppy (housing) input block diagram

(For board level see Chapter [Stingray board level camera: I/O pin assignment](#) on page 54)

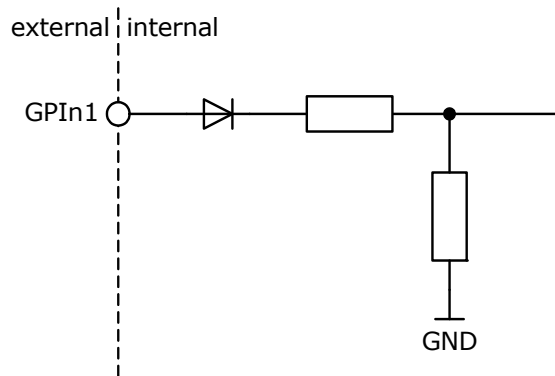

Figure 35: Guppy (housing) input block diagram

The inputs can be connected directly to +5 V. If a higher voltage is used, an external resistor must be placed in series.

**Caution**



**Guppy**

**Voltages above +36 V may damage the camera.**

**Max. 50 mA per input.**

Used input voltage	External series resistor
5 V	none
12 V	22 kΩ
24 V	56 kΩ
36 V	91 kΩ

Table 16: Guppy: external resistors for voltages higher than 5 V

**Guppy delay and minimum pulse width**

The **cycle delay** for all Guppy cameras is:

$t_{pdLH} < 3.0 \mu s$  and  $t_{pdHL} < 1.5 \mu s$

The **minimum pulse width** for all Guppy cameras is:

$t_p > 2.2 \mu s$

**Test conditions**

The input signal was driven with 12 V and a 2.2 k $\Omega$  pull down resistor to GND and a 22 k $\Omega$  series resistor.



## Guppy output description

### Guppy output block diagram

(For board level see Chapter [Guppy \(board level\) IO block diagram](#) on page 75)

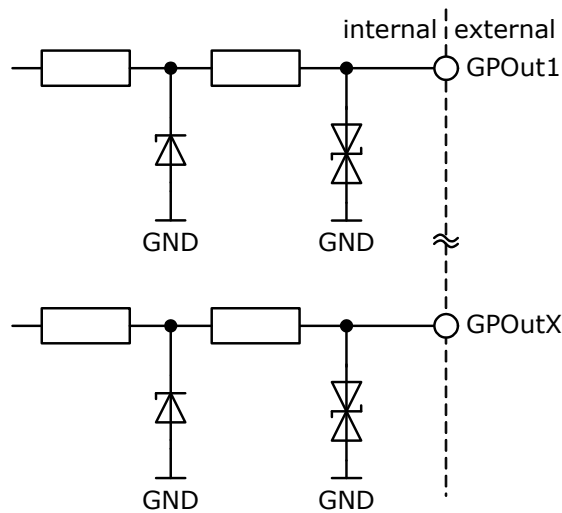

Figure 36: Guppy: output block diagram

#### Caution



#### Guppy

Max. 20 mA per output

OutVCC	Resistor value	
5 V	1 kΩ	~ 5 mA load recommended

Figure 37: Guppy: OutVCC and external resistor

#### Note



#### Guppy F-503:

IntEna is high, when all pixels are integrated simultaneously.

⇒ Using IntEna with electronic rolling shutter and global reset release shutter: see *Guppy Technical Manual, Chapter Trigger modi*.

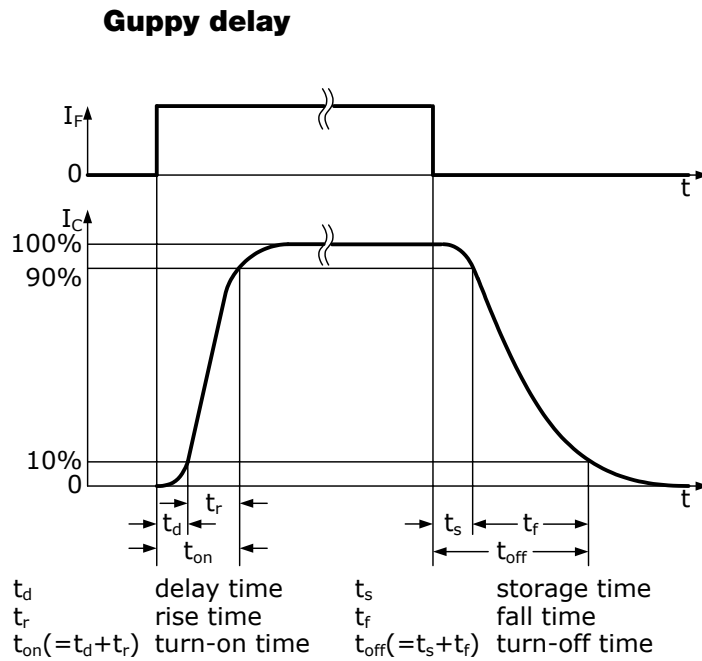

Figure 38: Guppy output switching times

For all Guppy models:

Parameter and value	
$t_d < 0.5 \mu s$	$t_s < 0.5 \mu s$
$t_r < 0.5 \mu s$	$t_f < 0.5 \mu s$
$t_{on} = t_d + t_r = < 1 \mu s$	$t_{off} = t_s + t_f = < 1 \mu s$

Table 17: Parameters for Guppy

**Test conditions**

Camera: Format\_7 Mode\_0, Mono8, S400, extended shutter set to minimum

Output: external 2.4 kΩ resistor to GND

### Guppy (board level) IO block diagram

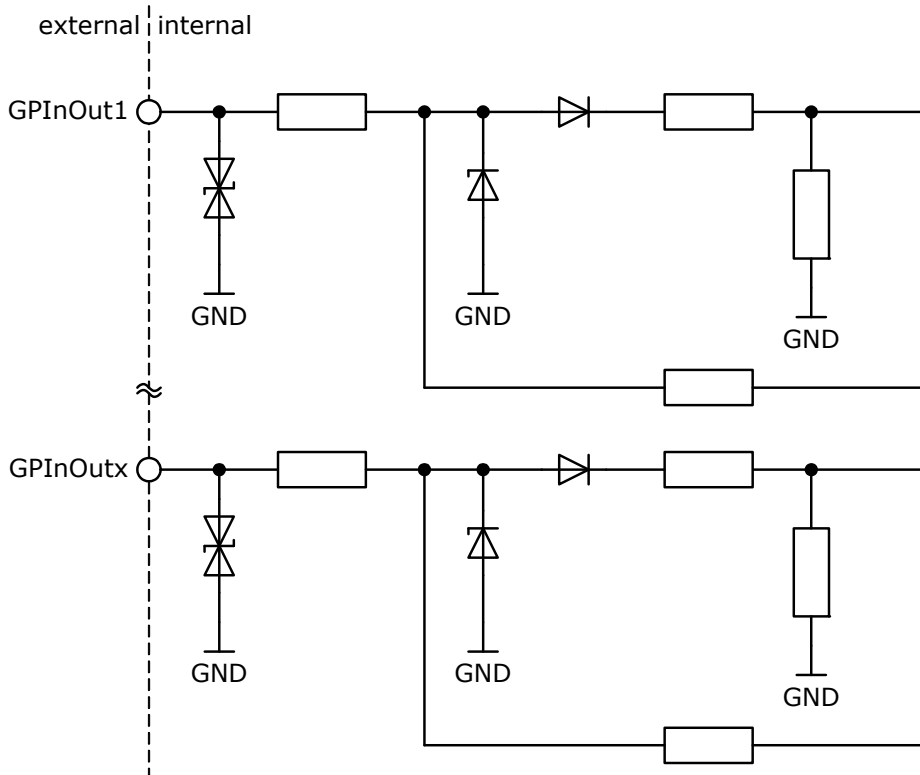

Figure 39: Guppy (board level) input block diagram

The GPIOs of the board level Guppy have the same electrical characteristics as the GPIOs of the standard (housing) Guppy.

### Guppy data

Currently RS232 data interface is not implemented.

### Guppy power

In accordance to IEEE 1394a specification the power supply (+8 V ... +36 V) should deliver a current of at least 1.5 A.

## Marlin camera interfaces

### Marlin camera I/O connector pin assignment

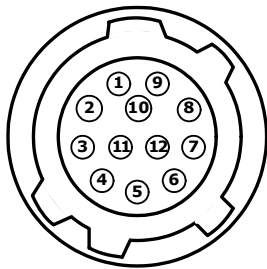

Pin	Signal	Direction	Level	Description
1	External GND		GND for RS232 and ext. power	External ground for RS232 and external power
2	External Power (CCD models only)		+8 ... +36 V DC	Power supply
3				
4	Camera In 1	In	$U_{in}(\text{high}) = 2 \text{ V} \dots U_{inVCC}$ $U_{in}(\text{low}) = 0 \text{ V} \dots 0.8 \text{ V}$	Camera Input 1 (GPIIn1) default: Trigger
5				
6	Camera Out 1	Out	Open collector	Camera Output 1 (GPOut1) default: IntEna
7	Camera In GND	In	Common GND for inputs	Camera Common Input Ground (In GND)
8	RxD RS232	In	RS232	Terminal Receive Data
9	TxD RS232	Out	RS232	Terminal Transmit Data
10	Camera Out Power	In	Common VCC for outputs max. 36 V DC	External Power for digital outputs (OutVCC)
11	Camera In 2	In	$U_{in}(\text{high}) = 2 \text{ V} \dots U_{inVCC}$ $U_{in}(\text{low}) = 0 \text{ V} \dots 0.8 \text{ V}$	Camera Input 2 (GPIIn2) default: -
12	Camera Out 2	Out	Open collector	Camera Output 2 (GPOut2) default: -

Figure 40: Marlin: Camera I/O connector pin assignment

## Marlin input description

### Marlin input block diagram

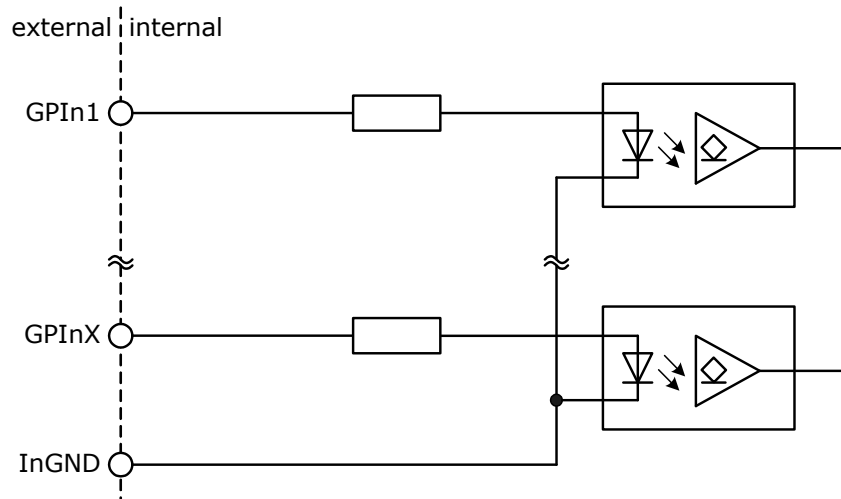

Figure 41: Marlin: input block diagram

The inputs can be connected directly to +5 V. If a higher voltage is used, an external resistor must be placed in series.

**Caution**

**Marlin**



**Voltages above +36 V may damage the camera.**

Used input voltage ( $U_{inVCC}$ )	External series resistor
5 V	none
12 V	0.82 k $\Omega$
24 V	2.2 k $\Omega$
36 V	3.3 k $\Omega$

Table 18: Marlin: external resistors for voltages higher than 5 V

Parameter	Value
Initial on-current	5 mA
Flux voltage of the LED (@ 10 mA)	1.5 V
Maximum off-current	0.25 mA
Maximum input current	15 mA

Table 19: Marlin: input parameters

**Marlin delay and minimum pulse width**

The **cycle delay** for all Marlin cameras is:

$t_{pdLH} < 1 \mu s$  and  $t_{pdHL} < 1 \mu s$

The **minimum pulse width** for all Marlin cameras is:

$t_p > 2.2 \mu s$

**Test conditions**

The input signal was driven with 12 V and a 2.2 k $\Omega$  pull down resistor to GND.

## Marlin output description

### Marlin output block diagram

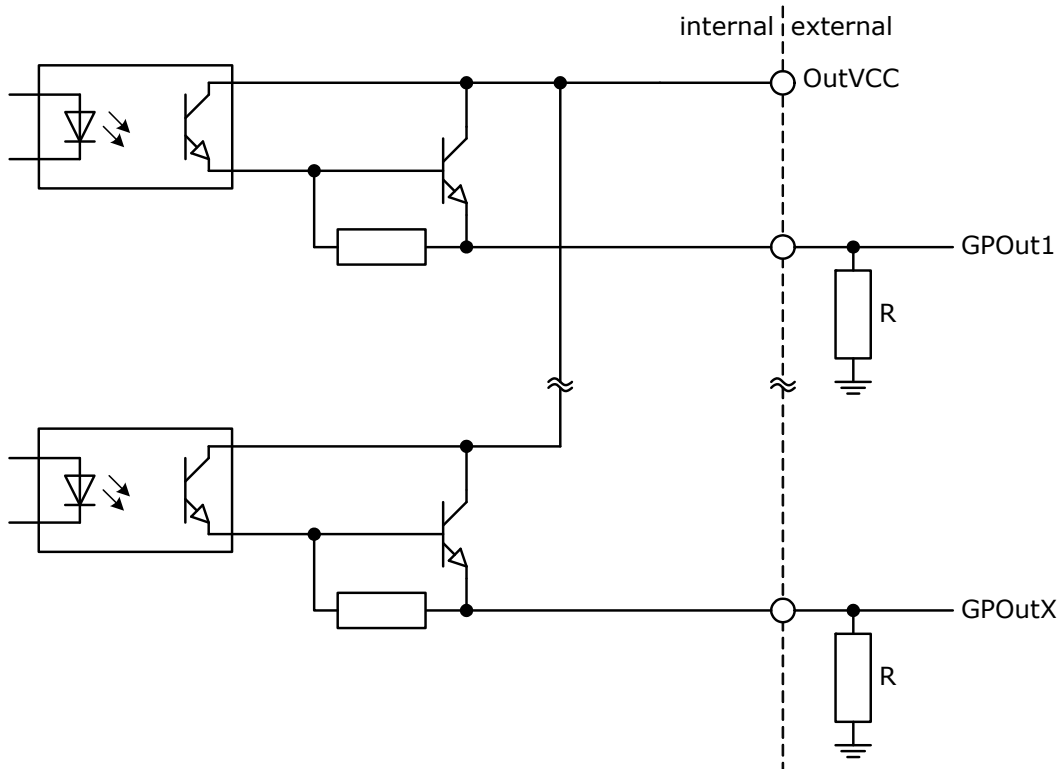

Figure 42: Marlin: output block diagram

#### **Caution** Marlin



- Max. 200 mA per output
- OutVCC > 36 V may damage the camera.

OutVCC	Resistor value	
5 V	1 kΩ	~ 5 mA load recommended
12 V	2.4 kΩ	
24 V	4.7 kΩ	

Figure 43: Marlin: OutVCC and external resistor

**Marlin delay**

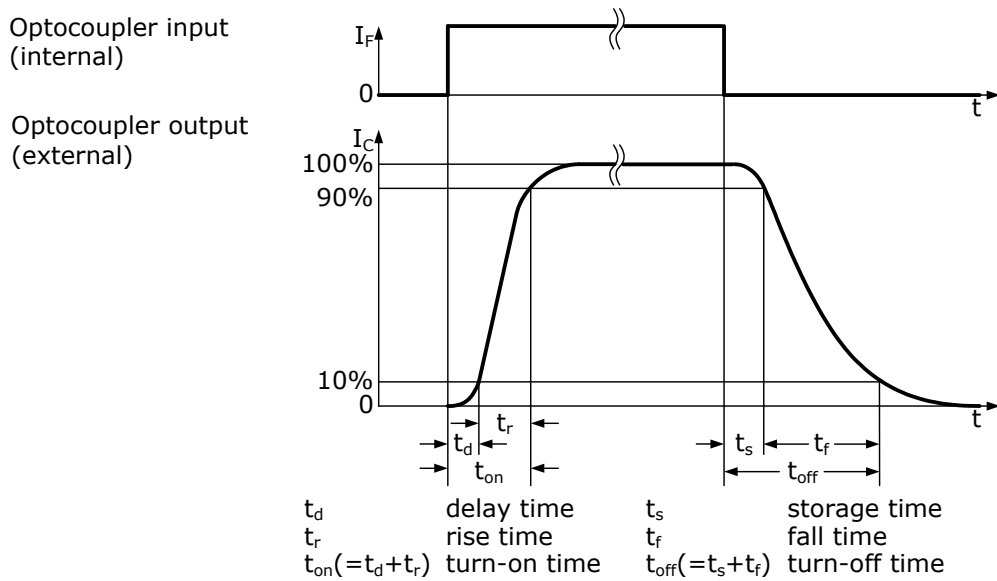

Figure 44: Marlin output switching times

For all Marlin models:

Parameter and value	
$t_d \approx 1 \mu s$	$t_s \approx 55 \mu s$
$t_r \approx 1 \mu s$	$t_f \approx 75 \mu s$
$t_{on} = t_d + t_r \approx 2 \mu s$	$t_{off} = t_s + t_f \approx 130 \mu s$ ( $t_{off}$ can deviate by $\pm 5 \mu s$ )

Table 20: Parameters for Marlin

**Test conditions**

Camera: Format\_7 Mode\_0, Mono8, S400, extended shutter set to minimum

Output: external 2.4 kΩ resistor to GND, power input for output ports set to 12 V

**Marlin data**

The RS232 data interface has a typical output voltage from  $\pm 4.2 V$ .

**Marlin power**

In accordance to IEEE 1394a specification the power supply (+8 V ... +36 V) should deliver a current of at least 1.5 A.



## Oscar camera interfaces

### Oscar camera I/O connector pin assignment

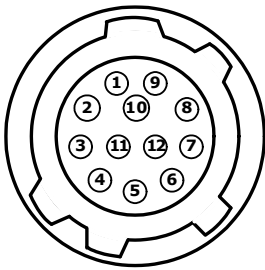

Pin	Signal	Direction	Level	Description
1	External GND		GND for RS232 and ext. power	External ground for RS232 and external power
2	External Power		+8 ... +36 V DC	Power supply
3				
4	Camera In 1	In	$U_{in}(\text{high}) = 2 \text{ V} \dots U_{inVCC}$ $U_{in}(\text{low}) = 0 \text{ V} \dots 0.8 \text{ V}$	Camera Input 1 (GPIIn1) default: Trigger
5				
6	Camera Out 1	Out	Open emitter	Camera Output 1 (GPOut1) default: IntEna
7	Camera In GND	In	Common GND for inputs	Camera Common Input Ground (In GND)
8	RxD RS232	In	RS232	Terminal Receive Data
9	TxD RS232	Out	RS232	Terminal Transmit Data
10	Camera Out Power	In	Common VCC for outputs max. 36 V DC	External Power for digital outputs (OutVCC)
11	Camera In 2	In	$U_{in}(\text{high}) = 2 \text{ V} \dots U_{inVCC}$ $U_{in}(\text{low}) = 0 \text{ V} \dots 0.8 \text{ V}$	Camera Input 2 (GPIIn2) default: -
12	Camera Out 2	Out	Open emitter	Camera Output 2 (GPOut2) default: -

Figure 45: Oscar: Camera I/O connector pin assignment

## Oscar input description

### Oscar input block diagram

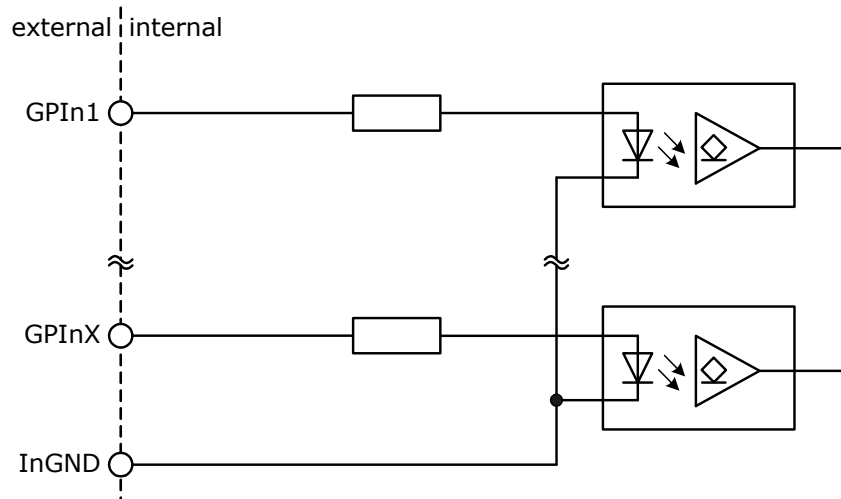

Figure 46: Oscar: input block diagram

The inputs can be connected directly to +5 V. If a higher voltage is used, an external resistor must be placed in series.

**Caution**

**Oscar**

**Voltages above +36 V may damage the camera.**



Used input voltage ( $U_{inVCC}$ )	External series resistor
5 V	none
12 V	0.82 k $\Omega$
24 V	2.2 k $\Omega$
36 V	3.3 k $\Omega$

Table 21: Oscar: external resistors for voltages higher than 5 V

Parameter	Value
Initial on-current	5 mA
Flux voltage of the LED (@ 10 mA)	1.5 V
Maximum off-current	0.25 mA
Maximum input current	15 mA

Table 22: Oscar: input parameters

**Oscar delay and minimum pulse width**

The **cycle delay** for all Oscar cameras is:

$t_{pdLH} < 1 \mu s$  and  $t_{pdHL} < 1 \mu s$

The **minimum pulse width** for all Oscar cameras is:

$t_p > 2.2 \mu s$

**Test conditions**

The input signal was driven with 12 V and a 2.2 k $\Omega$  pull down resistor to GND.

## Oscar output description

### Oscar output block diagram

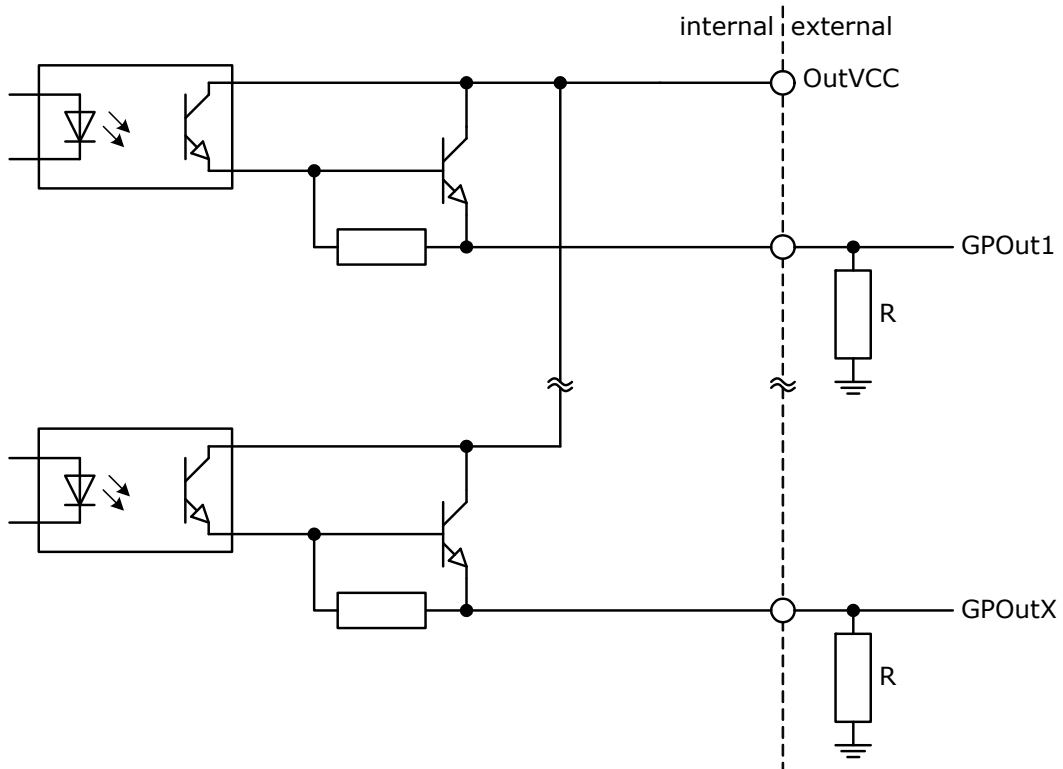

Figure 47: Oscar: output block diagram

**Caution** **Oscar**



- Max. 200 mA per output
- OutVCC > 36 V may damage the camera.

OutVCC	Resistor value	
5 V	1 kΩ	~ 5 mA load recommended
12 V	2.4 kΩ	
24 V	4.7 kΩ	

Figure 48: Oscar: OutVCC and external resistor

**Oscar delay**

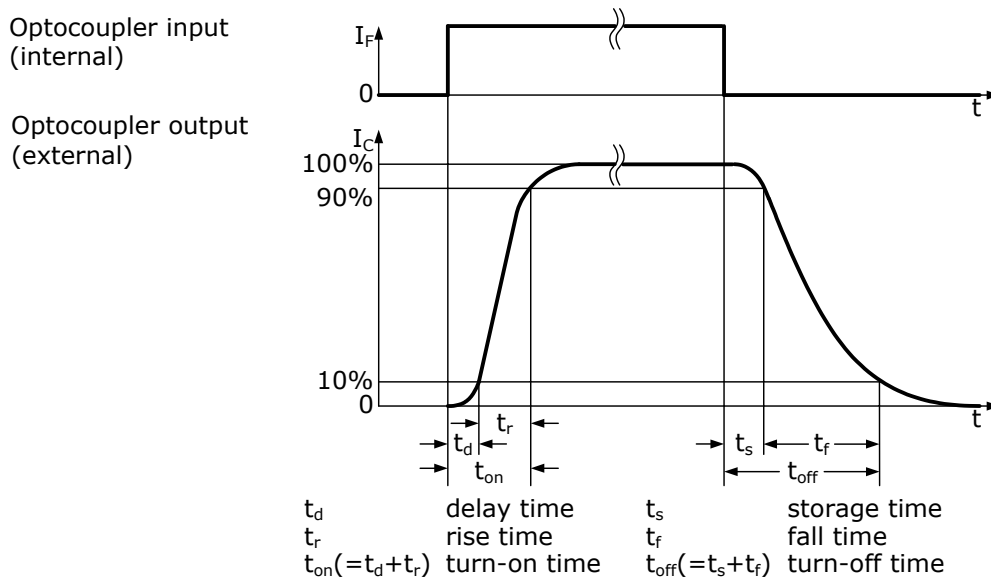

Figure 49: Oscar output switching times

For all Oscar models:

Parameter and value	
$t_d \approx 1 \mu s$	$t_s \approx 55 \mu s$
$t_r \approx 1 \mu s$	$t_f \approx 75 \mu s$
$t_{on} = t_d + t_r \approx 2 \mu s$	$t_{off} = t_s + t_f \approx 130 \mu s$ ( $t_{off}$ can deviate by $\pm 5 \mu s$ )

Table 23: Parameters for Oscar

**Test conditions**

Camera: Format\_7 Mode\_0, Mono8, S400, extended shutter set to minimum

Output: external 2.4 kΩ resistor to GND, power input for output ports set to 12 V

**Oscar data**

The RS232 data interface has a typical output voltage from  $\pm 4.2 V$ .

**Oscar power**

In accordance to IEEE 1394a specification the power supply (+8 V ... +36 V) should deliver a current of at least 1.5 A.

# Firmware update

Firmware updates can be carried out without opening the camera.

## Note



**For further information read the application note:  
How to update Guppy/Guppy PRO/Pike/Stingray firmware.**

**This application note and the firmware itself is only accessible for distributors. End customers have to contact technical support.**

# Index

## C

Cable GND.....	40
camera	
rear view .....	38
camera interfaces.....	38
common GND	
inputs .....	48, 55, 63, 76, 81
common vcc	
outputs .....	48, 55, 63, 76, 81

## D

document history .....	7
------------------------	---

## E

External GND .....	48, 55, 63, 69, 70, 76, 81
--------------------	----------------------------

## F

firmware update.....	86
----------------------	----

## G

GND for RS232 .....	48, 55, 69, 70, 76, 81
---------------------	------------------------

## H

hardware installation .....	36
-----------------------------	----

## I

IEEE 1394 adapter	
installing .....	36
IEEE 1394 port	
pin assignment.....	40
IEEE 1394a connector .....	40
IEEE 1394b connector .....	38, 42
inputs.....	38, 46, 47
common GND .....	48, 55, 63, 76, 81
installing	
IEEE 1394 adapter .....	36
IntEna .....	48, 55, 63, 69, 76, 81

## L

latching connectors.....	40, 42
Legal notice.....	2

## M

minimum pulse width	
Guppy.....	72
Guppy PRO.....	65
Marlin .....	78
Oscar.....	83
Pike.....	57
Stingray .....	50

## O

optical filter .....	18
outputs.....	46, 47
common vcc .....	48, 55, 63, 76, 81
OutVCC.....	48, 55, 63, 76, 81

## P

Power	
IEEE 1394b.....	42
power	
cable .....	18
connectors .....	23, 37
DC .....	23, 37
GND.....	48, 55, 63, 69, 70, 76, 81
IEEE-1394 pin assignment .....	40, 41
power down .....	23, 37

## R

rear view of camera.....	38
Reference documents	
USA .....	23
RS232 .....	48, 55, 69, 70, 76, 81
RxD_RS232 .....	48, 55, 69, 70, 76, 81

## S

safety instructions.....	18
SmartView	

starting.....	36
starting	
SmartView.....	36
styles.....	14
symbols.....	14

## T

TPA-	
IEEE 1394a.....	40
IEEE 1394a board level .....	41
IEEE 1394b .....	42
TPA (Reference ground)	
IEEE 1394b .....	42
TPA+	
IEEE 1394a.....	40
IEEE 1394a board level .....	41
IEEE 1394b .....	42
TPB-	
IEEE 1394a.....	40
IEEE 1394a board level .....	41
IEEE 1394b .....	42
TPB (Reference ground)	
IEEE 1394b .....	42
TPB+	
IEEE 1394a.....	40
IEEE 1394a board level .....	41
IEEE 1394b .....	42

## V

VCC	
IEEE 1394b .....	42
VG (GND)	
IEEE 1394b .....	42
VP	
IEEE 1394b .....	42
VP (Power, VCC)	
IEEE 1394b .....	42